

- Acc. to DIN EN 50205, DIN EN 61810-1, DIN EN 60664-1
- With forcibly guided contacts
- **Double and reinforced insulation between contact sets according to EN 50178**
- High dielectric strength
- High mechanical service life
- High switching reliability
- Compact size
- High thermal continuous current
- High voltage range

Applications

- Switchgear for safety technology
- Press controls

Approvals and Markings



Technical Data

Relais type		OA 5670
1.0 Relais coil		
1.1 Nominal voltage	DC V	6; 12; 20; 24; 48; 60; 110 (others on request)
1.2 Nominal consumption	W	1.0
1.3 Holding power (at 0.5 x UN)	W	0.25
2.0 Contacts		
2.1 Contact arrangement		2 NO and 2 NC; 3 NO and 1 NC
2.2 Contact material		AgSnO ₂ + 0.2 µm Au; AgNi + 0.2 µm Au, AgNi + 5 µm Au
2.3 Rated insulation voltage	AC V	250
Switching voltage min./max.	V	AC/DC 10 / DC 250, AC 400 (AC/DC 100 mV / 60 V) ¹⁾
2.4 Limiting continuous current I _{th}	A	3 x 6 (see operating voltage limit curve)
Switching current min./max.	A	10 mA ³⁾ / 6 (1 mA / 0.3 A) ¹⁾
2.5 Switching power min./max.	VA	3 / 1 500 (1 mVA / 7 VA) ¹⁾
Switching power min./max.	W	3 / 160 (1 mW / 7 W) ¹⁾ (s. limit curve for arc-free operation)
2.6 Switching capacity		
to IEC/EN 60947-5-1 AC 15 ⁴⁾	AC V/A	NO: 250 / 2 NC: 250 / 1
to IEC/EN 60947-5-1 AC 15 ⁵⁾	AC V/A	NO: 250 / 3 NC: 250 / 1
to IEC/EN 60947-5-1 DC 13 ⁴⁾	DC V/A	NO: 24 / 1 NC: 24 / 1
at 0.1 Hz DC 13 ⁴⁾	DC V/A	NO: 24 / 4 NC: 24 / 3
to UL 508		B300 / R300
2.7 Electrical life	switching cycles	at 1 s On, 1 s Off (see contacts service life)
at AC 230 V, 6 A, cosφ = 1	switching cycles	> 1.2 x 10 ⁵ AgNi 10
at DC 24 V, 6 A ohmsch	switching cycles	> 1.2 x 10 ⁵ AgNi 10
2.8 Switching frequency max.	switching cycles/s	10
2.9 Response time / Release time	ms	typically 11 / typically 6
2.10 Contact force NO / NC	cN	≥ 10
3.0 Other		
3.1 Mechanical life	switching cycles	≥ 50 x 10 ⁶
3.2 Temperature range	°C	- 40 ... + 75
3.3 Degree of protection, housing		Solder line proof RT II as option wash proof RT III
3.5 Vibration resistance		10 ... 200 Hz; NC 5 g; NO 10 g; IEC/EN 60068-2-6
3.6 Climate resistance		40 / 075 / 04 (climate category); A/B/D IEC/EN 60068-1
3.7 Short circuit strength 1 kA / AC 250 V	AgNi or AgSnO ₂	6 A gL EN 60947-5-1

¹⁾ Values for AgNi-Contacts + 5 µm Au

²⁾ 10 A total current at t = 20°C and coil voltage UN

³⁾ Typical values

⁴⁾ Values for AgNi-Contacts

⁵⁾ Values for AgSnO₂-Contacts

Technical Data

3.8	Insulation acc. to IEC 60664-1, EN 50178		double and reinforced insulation
	Rated insulation voltage	AC V	250
	Contamination level		3
	Overtoltage category		III
	Test voltage		
	Contact-Coil (1 min)	AC kV eff.	≥ 4
	Left contact-right contact (1min)	AC kV eff.	≥ 4
	Contact-Coil (1min)	AC kV eff.	≥ 3
	Open contact acc. to DIN EN 61810-1	AC kV eff.	1.5
	Transient voltage		
	Contact-Coil (1.2 - 50 μs)	kV	≥ 6
	Clearance and creepage distances		
	Contact-Coil	mm	≥ 8
	Left contact-right contact	mm	≥ 5.5
	Contact-Contact	mm	≥ 4.5
3.9	Weight	g	approx. 21
4.0 Packing			
4.1	on cardboard	piece	42
4.2	in case package	piece	210
5.0 Solder method			
5.1	Solder method /-temperature /-duration	°C / s	Wafer soldering / 260 / 5

Design Versions

U _N (DC V)	Voltage range (DC V)	Resistance at 20°C Ω±10%	OA 5670	
			.52 2NO, 2NC	.48 3NOS, 1NC
AgNi10 + 0,2 μm Au-contacts				
6	4.2 ... 8.4	36	3201	3211
12	8.4 ... 16.8	150	3202	3212
20	14.0 ... 28.0	400	3203	3213
24	16.8 ... 33.6	580	3204	3214
48	33.6 ... 67.2	2300	3205	3215
60	42.0 ... 84.0	3600	3206	3216
110	77.0 ... 154.0	12100	3207	3217
AgSnO ₂ + 0,2 μm Au-contacts				
6	4.2 ... 8.4	36	3221	3231
12	8.4 ... 16.8	150	3222	3232
20	14.0 ... 28.0	400	3223	3233
24	16.8 ... 33.6	580	3224	3234
48	33.6 ... 67.2	2300	3225	3235
60	42.0 ... 84.0	3600	3226	3236
110	77.0 ... 154.0	12100	3227	3237
AgNi10 + 5 μm Au-contacts				
6	4.2 ... 8.4	36	3241	3251
12	8.4 ... 16.8	150	3242	3252
20	14.0 ... 28.0	400	3243	3253
24	16.8 ... 33.6	580	3244	3254
48	33.6 ... 67.2	2300	3245	3255
60	42.0 ... 84.0	3600	3246	3256
110	77.0 ... 154.0	12100	3247	3257

Ordering Example

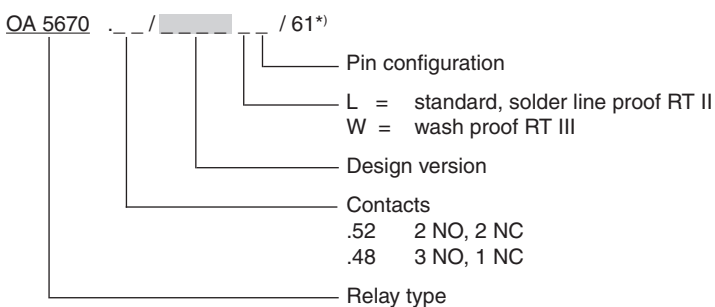

*) /61 cURus approval

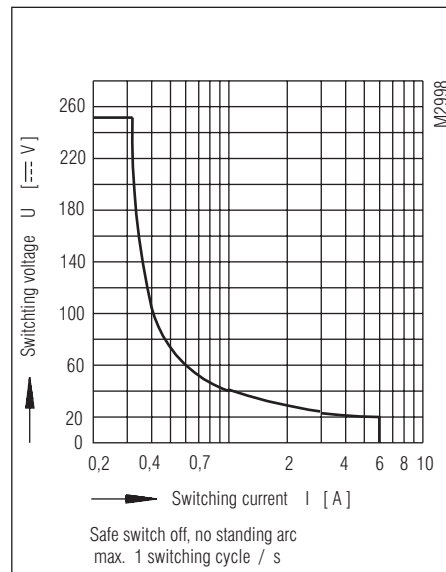
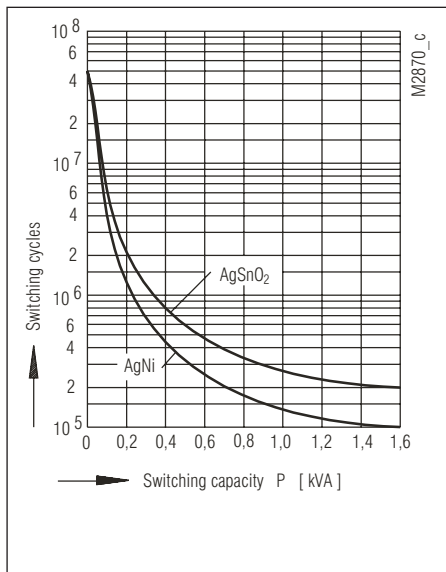
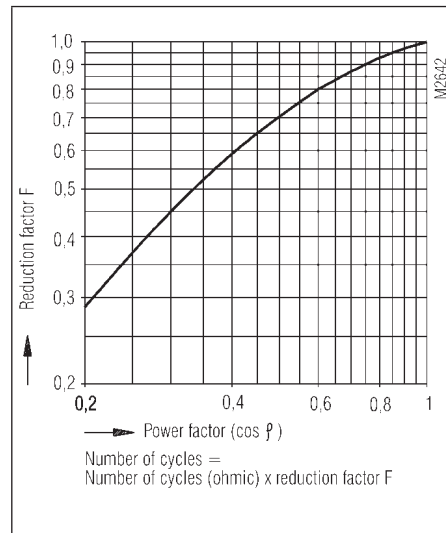
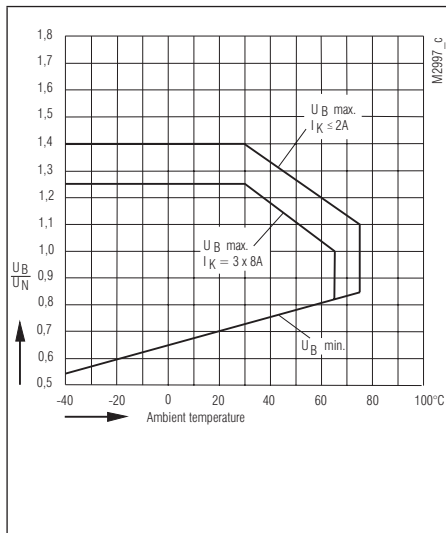

Drilling plan (solder side)

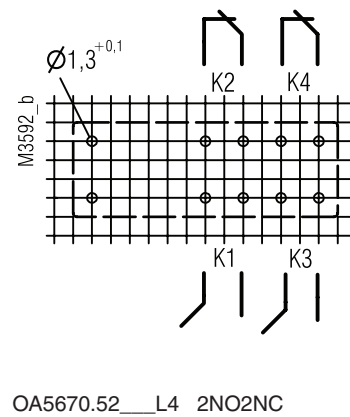
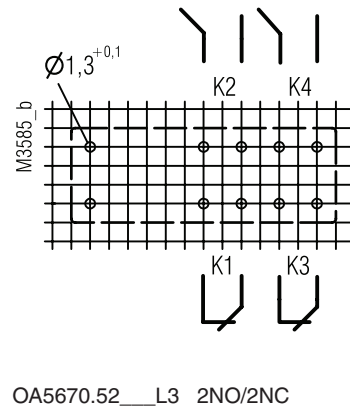
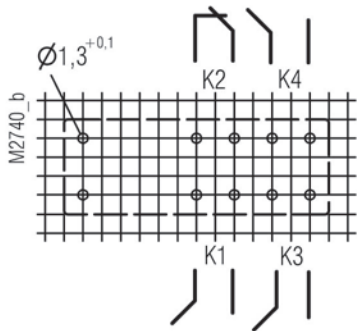
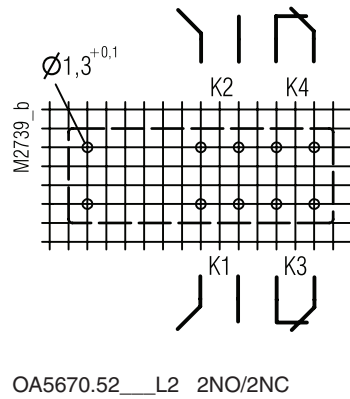
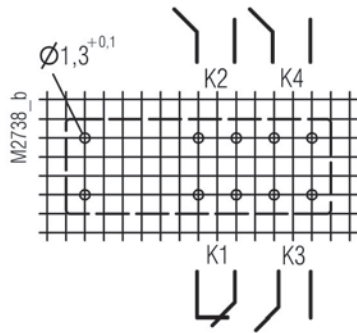
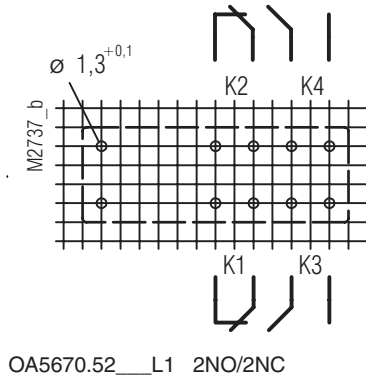
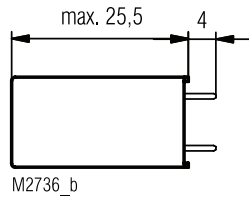
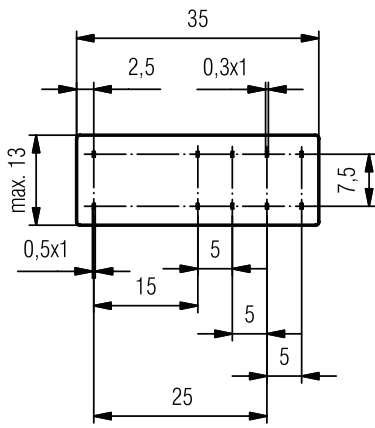

Connection for basic grid dimensions 2.5 mm as well as 2.54 mm according to IEC/EN 60097 and IEC 60326 average

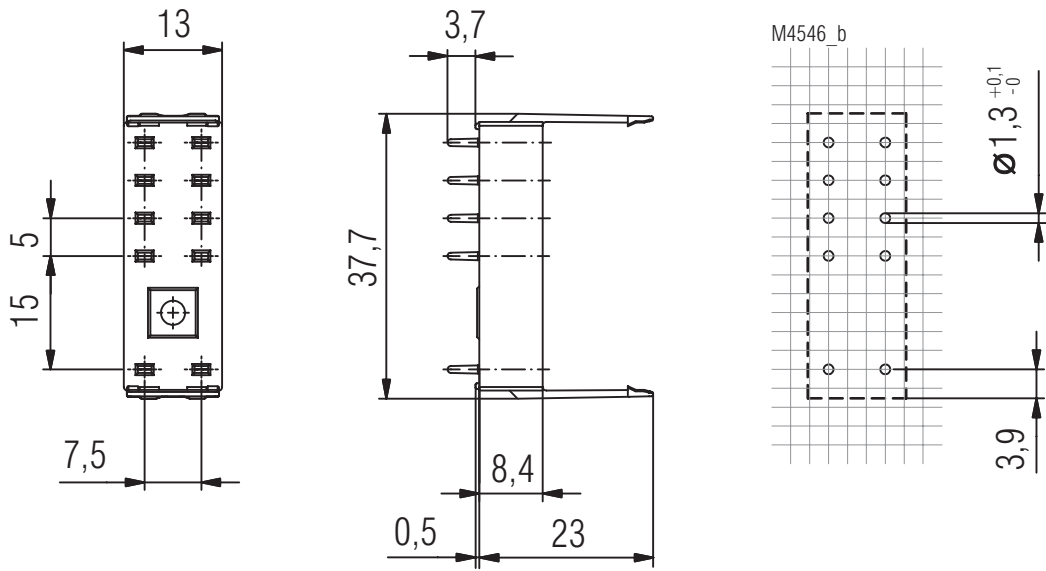

Article number: 0064297

