

PCB relays

Printed circuit board relay monostable OA / OW 5668

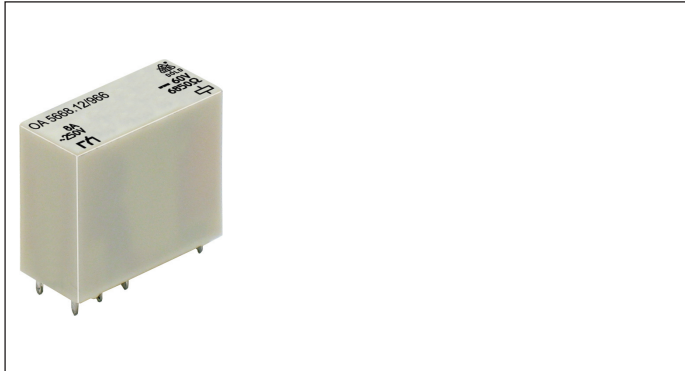

- Acc. to DIN EN 61810-1, DIN EN 60664-1
- Clearance and creepage distances, contact-coil ≥ 8 mm
- High dielectric strength ≥ 4 kV
- High temperature range - 40 ... + 75°C
- High mechanical service life $> 50 \times 10^6$ switching cycles
- Large voltage range $0.7 U_N \dots 2 U_N$
- As option wash proof RT III

Application

- Control technique
- Interface

Approvals and Marking



Technical Data

Relay type		OA/OW 5668
1.0 Relay coil		
1.1 Nominal voltage	DC V	5, 6, 12, 20, 24, 48, 60, 110
1.2 Nominal consumption	W	approx. 0.5
1.11 Voltage range	U_N	0,7 ... 2,0
1.3 Holding power (at $0.5 \times U_N$)	W	approx. 0.13
2.0 Contacts		
2.1 Contact arrangement		2 changeover contacts, optionally 2 NO or 2 NC
2.2 Contact material		AgSnO ₂ + 0.2 μ m Au on request; AgNi + 0.2 μ m Au, AgNi + 5 μ m Au
2.3 Rated insulation voltage	AC V	2 x 250
Switching voltage min./max.	V	AC/DC 10 / DC 250, AC 400 V (AC/DC 100 mV / 60 V) ⁴⁾
2.4 Limiting continuous current I_{th}	A	2 x 5 (s. see operating voltage limit curve)
Switching current min./max.	A	10 mA ³⁾ 2 x 8 together or 1 x 10 (1mA / 0.3 A) ⁴⁾
2.5 Switching power min./max.	VA	2 x 3 / 2 000 together or 1 x 2 500 (1mVA / 7 VA) ⁴⁾
Switching power min./max.	W	2 x 30 / 160 together or 1 x 200 (1mW / 7 W) ^{2) 4)}
2.6 Switching capacity		
to IEC/EN 60947-5-1 AC 15	AC V/A	NC: 230 / 1 NO: 230 / 2
to IEC/EN 60947-5-1 DC 13	DC V/A	NC: 24 / 1 NO: 24 / 1
2.7 Electrical life		at 1 s On, 1 s Off (see contact service life)
at AC 230 V, 6 A $\cos \varphi = 1$	switching cycles	1.5×10^5
2.8 Switching frequency max.	switching cycles / s	20
2.9 Response time / Release time	ms	$\leq 8 / \leq 10$
2.10 Contact force	cN	$\geq 10 / \geq 8$
3.0 Other		
3.1 Mechanical life	switching cycles	$\geq 50 \times 10^6$
3.2 Temperature range	°C	- 40 ... + 75 mounted without distance ($I_{th} = 2 \times 5$ A)
3.3 Degree of protection		Solder line proof RT II as option wash proof RT III
3.5 Vibration resistance		10 ... 55 Hz; 0,35 mm ampl.; max 5 g IEC/EN 60068-2-6
3.6 Climate resistance		40 / 075 / 04 (climate category); A/B/D IEC/EN 60 068-1

¹⁾ I on / I off

²⁾ see limit curve for arc-free operation

³⁾ Typical values

⁴⁾ Values for AgNi -Contacts + 5 μ m Au

Technical Data

3.8	Insulation acc. to IEC 60664-1, EN 50178		
	Rated insulation voltage	AC V	250
	Contamination level		2
	Overvoltage category		III
	Test voltage		
	contact-coil (1 min)	AC kV eff.	≥ 4
	contact-contact (1min)	AC kV eff.	≥ 2.5
	Transient voltage		
	contact-coil (1.2 - 50 μs)	kV	≥ 6
	Clearance and creepage distances		
	contact-cxoil	mm	≥ 8
3.9	Weight	g	35
4.0 Packing			
4.1	on cardboard in slipcase	piece	56
4.2	in case package	piece	280
5.0 Solder method			
5.1	Solder method /-temperature /-duration	°C / s	Wafer soldering / 260 / 5

Design versions

U _N DC V	Voltage range DC V	Resistance at 20°C Ω	Design version OA / OW	
			.12	.02
5	3.7 ... 9.5	50	941	571
6	4.5 ... 11.4	70	942	572
12	9.0 ... 22.8	270	943	573
20	15.0 ... 38.0	820	948	578
24	18.0 ... 45.6	1 100	944	574
48	35.0 ... 91.2	4 400	945	575
60	44.0 ... 114.0	6 850	946	576
110	80.0 ... 209.0	20 000	947	577

Ordering example

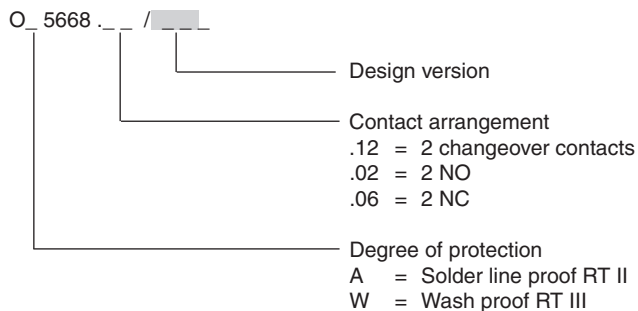

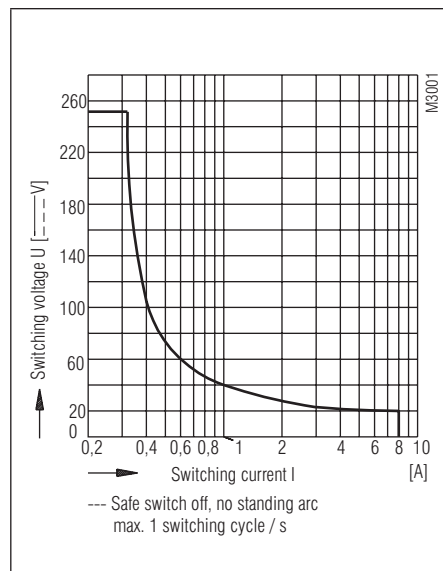
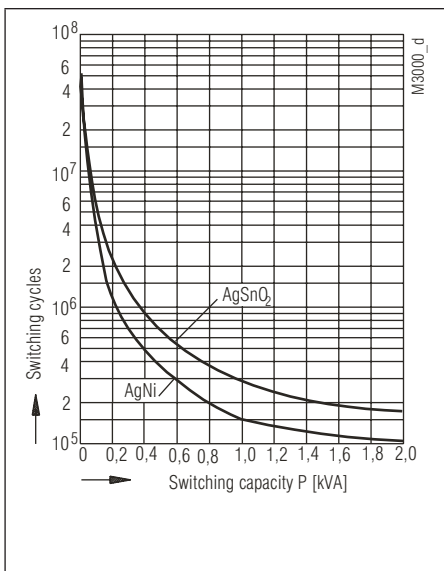
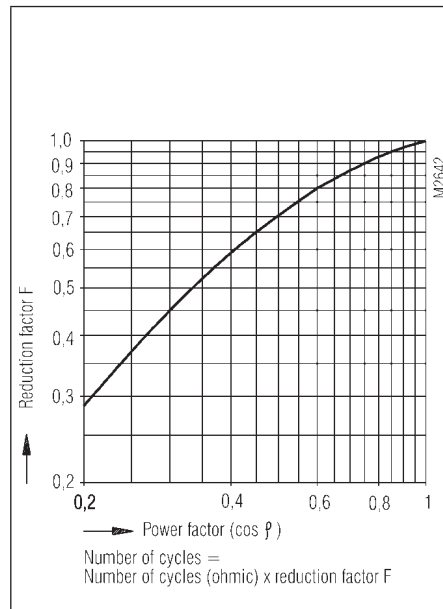
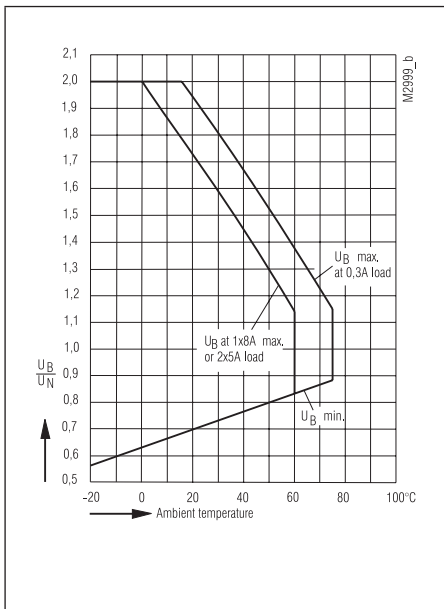

Drilling plan (solder side)

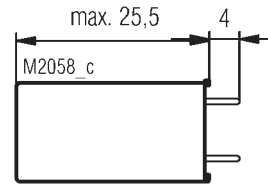
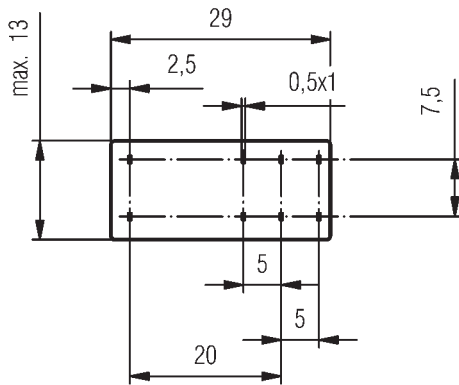
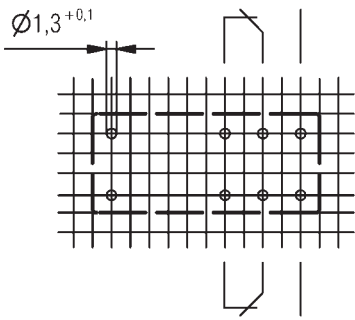

OA5668.12
OW5668.12

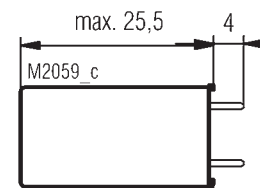
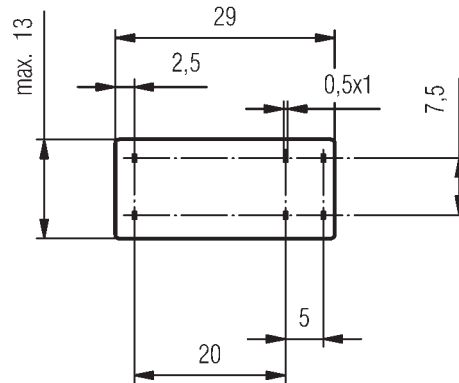
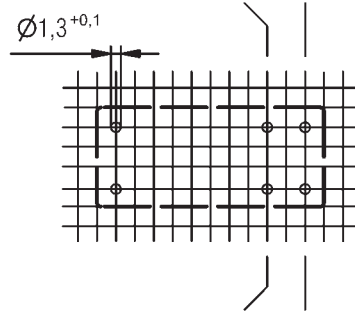

OA5668.02
OW5668.02

Connection for basic grid dimensions 2.5 mm as well as 2.54 mm according to IEC/EN 60097 and IEC 60326 average

Accessories

Socket ET 1415.021 Fixing clip ET 1415.025	Socket ET 1415.041	Socket ET 1415.044	Socket ET 1415.047
	<ul style="list-style-type: none"> Socket for DIN-rail incl. fixing clip 	<ul style="list-style-type: none"> Socket for DIN-rail incl. fixing clip incl. safe separation between coil and contacts according to DIN EN 60947-1, DIN EN 61140, DIN EN 60204 	
	<p>Fixing clip</p> <p>Function module</p> <p>Socket</p> <p>Screw terminals</p>	<p>Fixing clip</p> <p>Function module</p> <p>Socket</p> <p>Screw terminals</p>	<p>Fixing clip</p> <p>Function module</p> <p>Socket</p> <p>Cage clamp terminals</p>
Article number: 0034769	Article number: 0055571	Article number: 0059274	Article number: 0059270
Fixing clip (wire): 0034770 Fixing clip (plastic): 0047726	<p>Function modules</p> <p>ET1415.913: DC 24 V, with free-wheel diode and green LED Article number: 0056828</p> <p>ET1415.911: DC 24 V, with free-wheel diode and red LED Article number: 0055909</p> <p>ET1415.924: DC 60 V, with free-wheel diode and red LED Article number: 0062552</p> <p>ET1415.912: AC/DC 24 V, with varistor and green LED Article number: 0055910</p>		