

STS-System Benefits

- EU-Test certificate according to the directive 2006/42/EG, annex IX
- For safety applications up to PLE/Category 4 according to EN/ISO 13849-1
- Modular and expandable system
- Rugged stainless steel design
- Wireless mechanical safeguarding
- Combines the benefits of safety switch, solenoid locking and key transfer in a single system
- Easy installation through comprehensive accessories
- Protection against lock-in
- Coding level low, medium, high according to DIN EN ISO 14119:2014-03

Features STS-ZRHA

The unit is particularly suitable for applications with:

- Partial body access (no lock-in danger)
- Setup mode
- Single-channel/ redundant/ diverse safety circuits
- Rugged ambient conditions

Approvals and marking



Function

Safety switch (type 2) for separating guards with electromagnetic solenoid locking.

Application

To secure separating guards such as safety gates and hoods in machine and plant engineering.

Design and Operation

STS solenoid locking units prevent opening of separating guards and keep them closed as long as there is a risk of injury in the secured plant.

Attention!



Hazards must be ruled out before a key can be entered and the movable part of the guard can then be opened!

The STS solenoid locking unit is to be integrated into a system and connected with a control unit so that the hazardous machine can run only when the guard is locked and closed.

An access can only be opened and the actuator removed from actuator module A after a release signal was sent by the machine control to the STS-ZRHA solenoid locking unit. The movable part of the guard can be opened and closed as long as the release signal is still applied; the solenoid locking is not activated. The solenoid locking is activated again once no more release signal is applied and the guard is closed. The machine can now be restarted.

Actuator and magnet position are monitored by separate contacts. This makes this solenoid locking unit especially suitable for the setup mode of a machine.

STS-ZRHA is usually used in the system in connection with additional STS units and SAFEMASTER products (e.g. release by speed monitor UH 5947, standstill monitor LH 5946 or speed/standstill monitor BH5932).

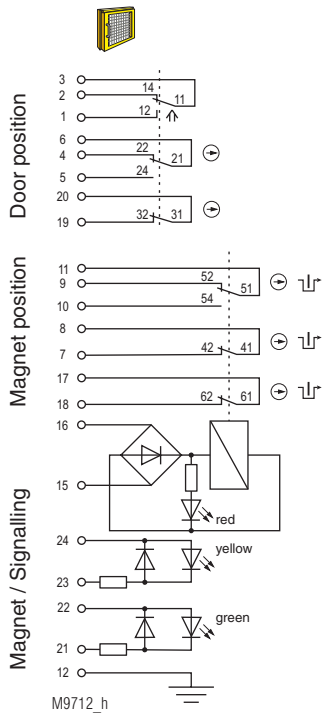

Fig. 1:
Solenoid locking activated:
Magnet locked,
Actuator inserted,
Door closed

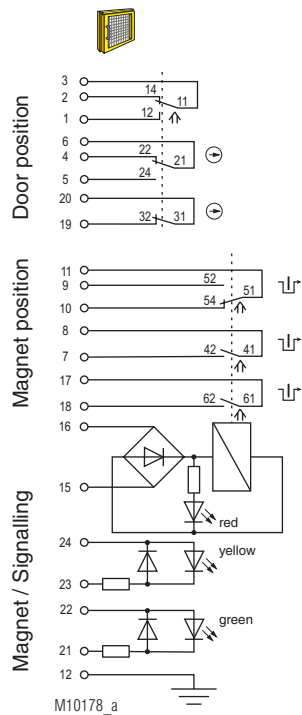

Fig. 2:
Solenoid locking deactivated:
Magnet released,
Actuator inserted,
Door closed

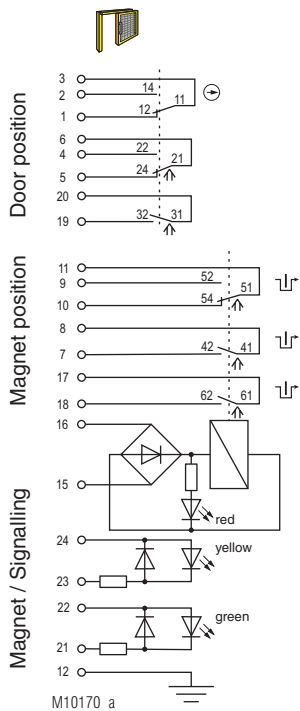

Fig. 3:
Solenoid locking deactivated:
Magnet released,
Actuator removed,
Door open

Switching logic

		Door contacts		
		3	2	1
Door contacts	3			Fig. 1
	6			Fig. 2
	19			Fig. 3
Magnet contact	11			
	7			
	17			
Control signal Magnet	15			
	16			

■ closed
□ open

The state shown in **Figure 3** does not depend on the control signal of the magnet.
If the control signal is applied and the actuator inserted the solenoid locking changes to the state of **Figure 2**.
If no signal is applied and the solenoid locking is inserted the solenoid locking changes to the state of **Figure 1**

Enclosure: Stainless steel V4A / AISI 316L
 Degree of protection: IP 65
 Temperature range standby current principle: - 25 °C to + 60 °C
 Temperature range load current principle: - 25 °C to + 40 °C
 Storage temperature: - 40 °C to + 80 °C
 Mechanical principle: Rotating axis with redundant actuation
 Connection method: Cage tension spring clamping
 min. connection cross-section: 0.25 mm²
 max. connection cross-section: 0.75 mm²
 Cable entry: 1 x M20 x 1.5
 B10_d: 2 x 10⁶ switching cycles
 Electrical service life: 5 x 10⁶ switching cycles
 Locking force: min. 1000 N
 Shearing force: depending on actuator
 Solenoid locking principle: Standby current, failure locking-proof
 Magnetic principle: Standby current or load current
 min. operating speed: 100 mm/s
 max. operating speed: 500 mm/s
 (by exception, 1500 mm/s is permitted)
 max. switching frequency: 360/h
 Operating mode: 100% ED
 Nominal voltage U_N: AC/DC 24 V
 Nominal voltage range: 0.85 ... 1.1 U_N
 Power consumption: 6 W
 Rated impulse voltage: 0.8 kV
 Rated insulation voltage: ≤ 50 V
 Contacts
 Door position: 1 NC contact, 2 diverse changeover contacts
 Magnet position: 2 NC contacts + 1 changeover contact
 Switching principle: Changeover contact with forced-opening snap-action switches
 Max. operating current standby current principle: 2 A
 Load current principle: 1 A
 Rated conditional short circuit current: 1000 A
 Contact material: Ag / AgSnO₂
 Short circuit strength, max. fusing: 2 A gG
 Utilization category of switching elements to AC 15: 1 A / AC 230 V
 to DC 13: 0.5 A / DC 60 V
 Indicator LED red: Magnet energized
 LED yellow/green (separate selection possible)
 EN ISO 13849-1:2008
 DIN EN ISO 14119:2014-03
 EN 60947-5-1:2005
 GS-ET-15:02.2011
 GS-ET-19:02-2011
 GS-ET-31:02-2010
 Intended use: up to max. cat. 4, PL e according to EN ISO 13849-1
 Mounting: according to DIN EN 50041
 Contact elements: IEC EN 60947-5-1 Appendix K
 Additional requirement for cat. 4 structure (as single unit): Add 2nd actuator module, Type STS-ZRHBA
 Diagnostic coverage (DC), (mechanical):
Logic and output
 STS-ZRHA: **cat. 2** 60 % **cat. 3** 90 % **cat. 4** 90 %
 STS-ZRHBA: 90 % 90 % 99 %
 Protection against faults of common cause: see table in STS design guide
 Repair and replacement: by manufacturer only
 Test intervals: min. once a year
 for PL a to d: min. once a month
 for PL e:

Ordering Example

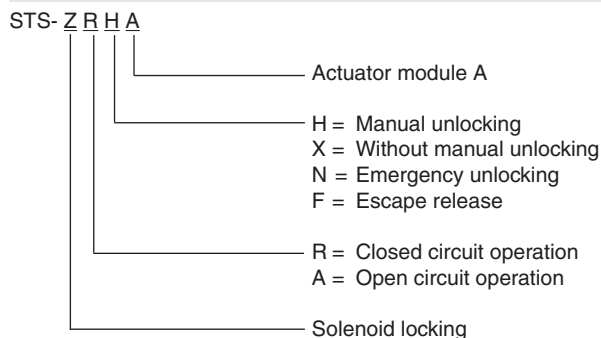

Versions of the solenoid locking module

- ZRX Solenoid locking standby current principle
- ZRH Solenoid locking standby principle with manual unlocking
- ZRN Solenoid locking standby principle with emergency unlocking

Variants and Combination Options

Because of their modular design the basic units of the SAFEMASTER STS System can be combined and expanded according to customer requests. This allows for a variety of possible units and functions.

Overview of the basic units

Functions	Safety switches design type 2	Safety switches design type 2 with solenoid lock	Mechanical units design type 2	Mechanical units with electrical monitoring	Mechanical units with electrical release
Units with standard function	SXA	ZRHA	M10A	RXK01M RX10A	YRXKM
Units with mechanical lock and forced key extraction	SX01A	ZRH01A	M11A	RXK11M RX11A	YRX10A
Units with optional key extraction	SXB01M	ZRHB01M	M10B01M	RX10K01M	YRX10B01M
Units without actuator	SX01M	ZRH01M	M12M	RX11M	YRX11M

For additional information refer to the data sheets of the individual modules and other basic units.

Data sheets

- STS Solenoid locking modules ZRX/ZRH/ZAX
- STS Actuator module A



Take advantage of the advice of the **E. DOLD & SÖHNE KG** specialists regarding the choice of units and combination of a system.

Dimensional Drawing [mm]

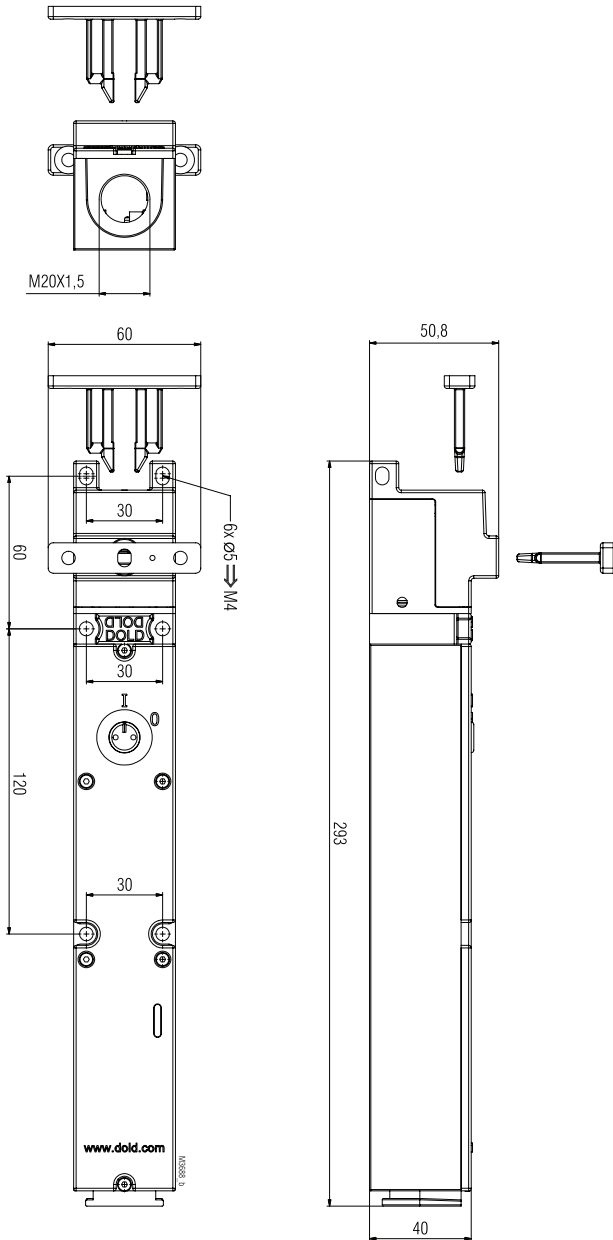

Clearance tolerances $\pm 2\%$

