

STS-System Benefits

- EU-Test certificate according to the directive 2006/42/EG, annex IX
- For safety applications up to PLe/Category 4 according to EN/ISO 13849-1
- Modular and expandable system
- Rugged stainless steel design
- Wireless mechanical safeguarding
- Combines the benefits of safety switch, locking module and key transfer in a single system
- Easy installation through comprehensive accessories
- Protection against lock-in
- Coding level low, medium, high according to DIN EN ISO 14119:2014-03

Features STS-B and STS-D

- Actuator module with an insertion opening
- Module expansions possible below and above the module
- Choice of direction in 4 increments of 90°
- Can be coded

Installation Examples

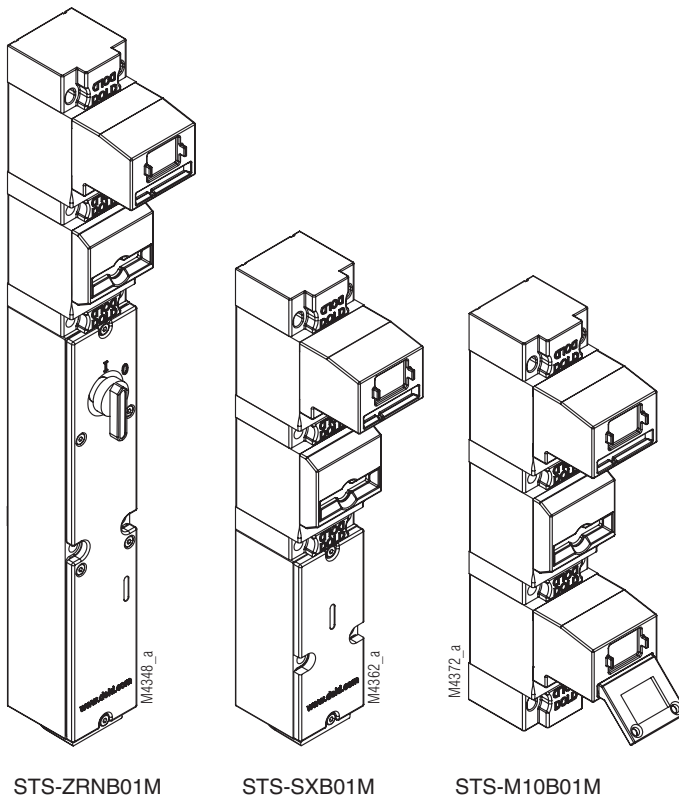

STS-ZRNB01M

STS-SXB01M

STS-M10B01M

Approvals and Marking



Application

The STS-B and STS-D actuator modules are assembled together with other modules into a STS unit and used in connection with an actuator. The actuator modules are then always part of the STS unit and connected with the stationary part of a separating guard while the actuator is mounted on the movable part of a separating guard. The actuator modules can be installed in 4 positions, each turned by 90°.

ATTENTION!



Mechanical function modules can be installed above and/or below the key module!

Electrical modules can only be installed below the key module!

Design and Operation

The extremely robust and flexible actuator module ensures safe access, for instance, to a guard or protective door.

The function of the actuator module is ensured only in combination with additional function modules, e.g. switch, door lock and/or key modules. The mechanical function modules can be installed both below and above actuator modules B and D. The switching and solenoid lock can only be installed below actuator modules B and D.

When securing separating guards it must be ensured then that hazardous movements when opening the movable part of the guard will be stopped. Actuator module B or D can transfer the release or locking of a protective door or hood mechanically. A door, for example, can thus be opened or kept closed.

In addition to function and sequence, the operating frequency of guards can also be realised with the actuator module.

Primary or secondary entries can be defined depending on the position of a B module in an STS unit or STS system. A primary access which is opened frequently, can be realised, for example with an STS-SXB03M unit. The 3 keys of this unit may be used to operate secondary entries which are not used as frequently.

STS-D module

The STS-B module is also available as a coded model with the type designation actuator module STS-D. This coded actuator module is always delivered in pairs with an associated actuator which is also coded. Different types of code available. The coding used is neither identified on the actuator module nor on the actuator.

Technical Data

Enclosure: Stainless steel V4A / AISI 316
Ambient temperature: - 40°C bis + 100°C
Application: only as part of a unit of the
SAFEMASTER STS series
Coding level according to DIN EN ISO 14119:2014-03
Actuator module B coding level low
Actuator module D coding level medium

Dimensional Drawing [mm]

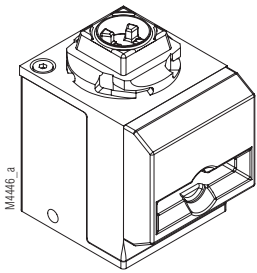
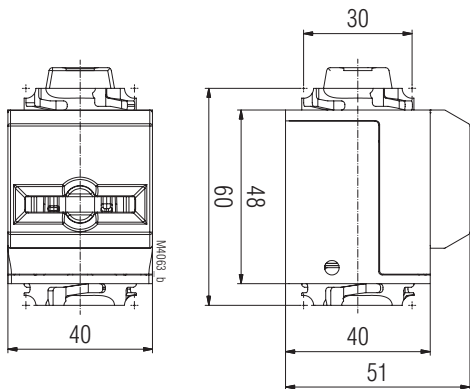

Ordering Designation

Actuator module STS-B
Article number: 0061873

Actuator module STS-D
Article number: 0063586