

STS-System Benefits

- EU-Test certificate according to the directive 2006/42/EG, annex IX
- For safety applications up to PLe/Category 4 according to EN/ISO 13849-1
- Modular and expandable system
- Rugged stainless steel design
- Wireless mechanical safeguarding
- Easy installation through comprehensive accessories
- Protection against lock-in
- Coding level low, medium, high according to DIN EN ISO 14119:2014-03

Features STS-K and STS-E

- Actuator module with an insertion opening
- Module expansions possible below and above the module
- Can be coded
- Choice of direction in 4 increments of 90°
- Module with (compared to actuator models B and D) inverted function
- Especially suited for difficult installation positions or additional actuator monitoring

Installation Examples

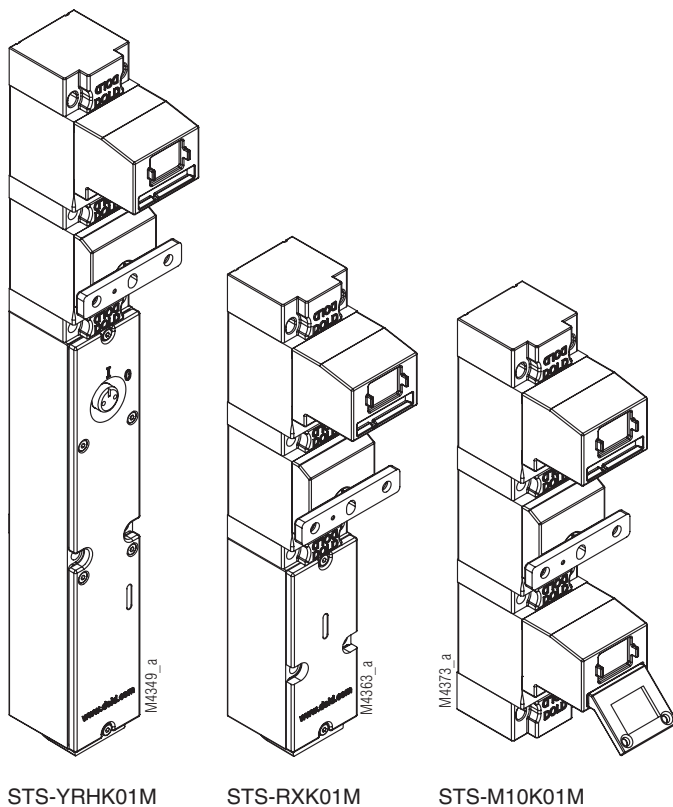

STS-YRHK01M

STS-RXK01M

STS-M10K01M

Approvals and Marking



Application

STS-K and STS-E actuator modules are assembled together with other modules into an STS unit and used in connection with an actuator. The actuator modules are then always part of the STS unit and connected with the stationary part of a separating guard while the actuator is mounted to the movable part of a separating guard. The actuator modules can be installed in 4 positions on the STS unit, each turned by 90°.

ATTENTION!



Mechanical function modules can be installed above and/or below the key module!

Electrical modules can only be installed below the key module!

Design and Operation

The actuator module STS-K offers the option of inverting SAFEMASTER STS functions. Externally, it is identical to the actuator module STS-B, but it has an inverse direction of action. This feature allows for an inverse structure of STS units with other monitoring functions. Standard STS units and inverse functional units can be combined in a key transfer system without any problem.

Example for inverting a function

With the mechanical interlock STS-M10A the unlocking of the actuator in the actuator module A takes place by the introduction of the matching key into the STS-10 key module. The actuator module is then positioned above the key module.

The STS-MK01M unit has the same functionality. However, with this unit the STS-K actuator module with inverting function is located below the STS-01 key module. For some local conditions this design sequence may be beneficial.

Function Inversion with Electrical Monitoring Option

Apart from the sequential inversion of the modules used in the module combination the integration of the actuator module STS-K offers an electrical monitoring option of the actuator. If, for example, a guard door position shall not only be monitored mechanically but also electrically, the STS-RXK01M is the suitable unit. To unlock the actuator, the matching key must be inserted into the key unit above. Only after that can the actuator be removed. With the actuator removal several contacts of the switch module STS-RX are actuated at the same time.

In contrast to the STS-RXK01M the switch contacts with the normally functioning STS-SX10A unit monitor the key insertion and not the removal of the actuator. Therefore there is no possibility of checking with this unit whether the access was actually opened.

The contacts of switch module STS-RX can be used both as signal contacts and safety feature. With a safety-related contact the use of a safety switching device with changeover contact principle or antivalence switching is required.

When using the actuator module STS-K with inverting function, the other functions such as key change are preserved. The identification of the STS unit is done from the bottom to the top as always. However, the operating sequence is inverted.

Function Inversion with Locking Modules

The actuator module STS-K can also be combined with solenoid lock module, for instance, the STS-YRH.

In this case the solenoid lock module no longer works as a door closure but rather unlocks mechanically functioning units for actuator removal. This combination is suitable for systems with a very high risk of being locked in where escape unlocking cannot be used; it is also used for escape sluices. The contacts of the solenoid lock module STS-YRH can be used both as signal contacts and safety-related. With a safety-related contact the use of a safety switching device with changeover contact principle or antivalence switching is required.

Example STS-YRHK01M

This STS unit functions similar to the STS-MK01M, but the actuator can only be inserted into the actuator module if a signal is applied to the solenoid of the locking module unit.

Example STS-YRHK11M

This STS unit functions similar to the STS-MK11M, but the actuator can only be inserted into the actuator module when a signal is applied to the solenoid of the solenoid lock unit. After that the key can be changed.

Circuit Diagrams (example STS-RXK01M)

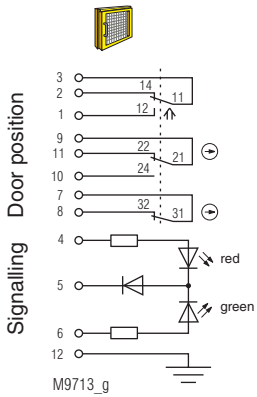

Fig. 1:
Locking module activated:
Key (top) removed,
Actuator (bottom) inserted,
Door closed

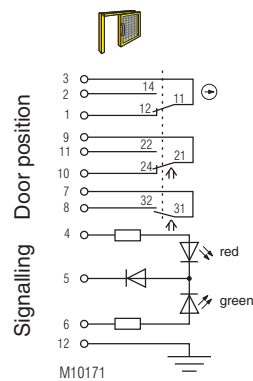

Fig. 2:
Locking module deactivated:
Key (top) inserted,
Actuator (bottom) removed
Door unlocked and open

Switching logic

		Fig. 1	Fig. 2
Door contacts	3	2	1
	9	11	10
	7	8	

■ closed
□ open

Circuit Diagrams (example STS-YRHK01M)

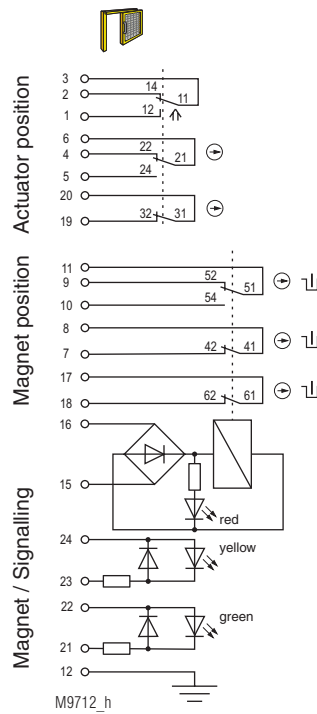

Fig. 3:
Blocking function deactivated:
Magnet locked, actuator
removed and not pluggable
Door open

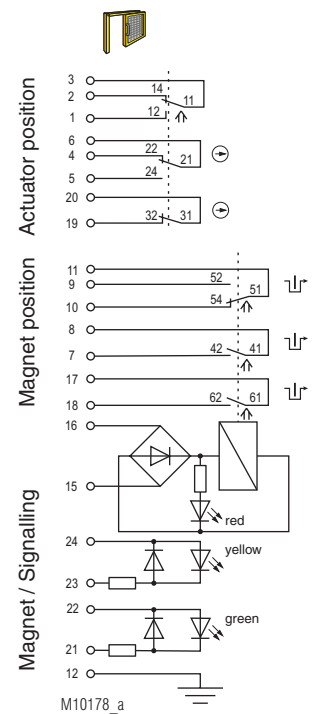
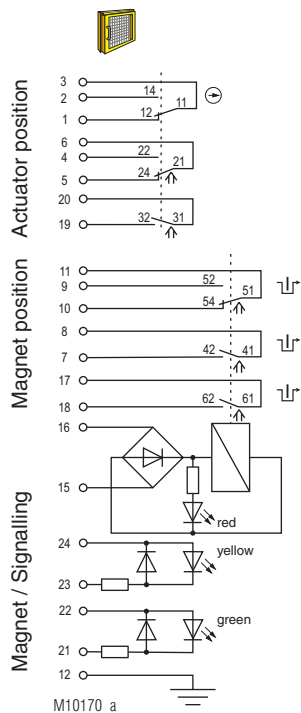

Fig. 4:
Blocking function when
deactivated:
Magnet released, actuator
removed and pluggable
Door open



Switching logic

			Fig. 3	Fig. 4	Fig. 5
Actuator contacts	3	2			
	3	1			
	6	4			
	6	5			
Magnet contact	11	9			
	11	10			
	7	8			
	17	18			
Control signal Magnet	U _N				
	15	16			

■ closed
□ open

The state shown in **Figure 5** does not depend on the control signal of the magnet.
If the control signal is applied and the actuator removed the locking module drops to the state of **Figure 4**.
If no signal is applied and the locking module is removed the locking module changes to the state of **Figure 3**

Fig. 5: Blocking function when deactivated:
Magnet released, actuator inserted, key removed or inserted, door closed

Enclosure: Stainless steel V4A / AISI 316
 • 1 Key insertion opening
 Ambient temperature: - 25 °C to + 60 °C
 Application: only as part of a unit of the SAFEMASTER STS series

Dimensional Drawing [mm]

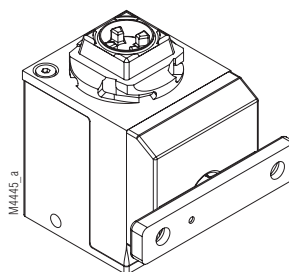
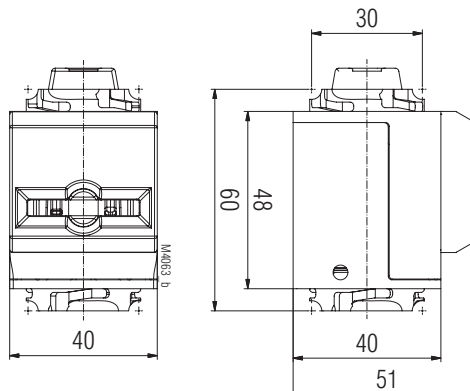

Alternative STS Units

The following overview shows some examples of Alternative STS Units with normal and inverted functions:

normal	inverted
STS-M10A	STS-MK01M
STS-M11A	STS-MK11M
STS-M12A	STS-MK21M
STS-M10B01M	STS-M10K01M
STS-M10B02M	STS-M20K01M
STS-RX10A	STS-RXK01M

The units specified offer the same functions, only the operating sequence is different. In the event of switch/Locking modules the monitored module logically changes.

Diagnostic Coverage (DC)

When using an actuator module STS-K or STS-E above an electrical STS module such as STS-RX or STS-YRH, the diagnostic coverage (DC value) needs to be determined by the mechanical STS module only in the first step.

To determine the diagnostic coverage of a STS unit with inverted function an overview of the functionally identical STS units with normal function is provided in **Alternative STS Units**. The respective diagnostic coverages can be found in the SAFEMASTER STS design guide.

The diagnostic function of the electrical STS module is to be considered as 1 or 2-channel system, depending on the design of the circuits. The DC value of the mechanical STS component is included in the calculation of the diagnostic coverage according to EN ISO 13849-1 to assess the key transfer function as subsystem. For more information on this subject refer to the SAFEMASTER STS design guide.

Variants and Accessories

STS-E actuator module with coded actuator

The actuator module STS-K can also be designed with a coded actuator just as the STS-B actuator module. The delivery of the actuator module and the actuator is always done in pairs. Different types of code available. The coding used will not be identified on the actuator. Additional delivery and separate orders of components are not possible. The type designation of the coded actuator module is STS-E.

Example: STS-ME01M
 Coding level medium according to DIN EN ISO 14119:2014-03

Devices with several actuators

If several actuators are needed for an application, for instance, for the implementation of categories 4 or 3, several STS-K actuator modules can also be installed next to each other. However, they cannot be connected with an STS-A actuator module as is the case with normally functioning versions.

An example of an STS unit with double actuator is the STS-MKK01M or the STS-RXKK01M. When connecting two actuator modules, care should be taken that the introduction of both actuators into the associated actuator modules takes place at the same time. As an option, the bottom actuator can be introduced first and then the top one later. If the actuators are both coded the same, it has no significance for the assembly and function of the STS unit.

Ordering Designation

Actuator module STS-K
 Article number: 0062326

Actuator module STS-E
 Article number: 0064978

