

Door-opening buttons GB. 08.08 Item-No.: 1000112
Further product catalogues are included within our general catalogue:

Hand-pole buttons: Item-No.: 1000114

Warning-, signal- and display units for road- and rail vehicles: Item-No.: 1000116

LED-lamps for public areas: Item-No.: 1000118

Wiring systems for switching- and display units: Item-No.: 1000120

Give us a call (Tel. +49 2353 66796-0)
or order per internet www.escha.tsl.de

Welcome to ESCHA TSL Door-Opening Buttons Catalogue.

ESCHA launched the first short-stroke button 25 years ago. Since then, we have developed into a specialist in custom-made switching- and signal solutions for road- and rail vehicles.

Our buttons are currently manufactured in over 2,000 different versions and are getting more daily. This catalogue is your guide to a wide range of switching variants, mounting solutions, pictograms and colours.

Talk to us about the button meeting your specific requirements.

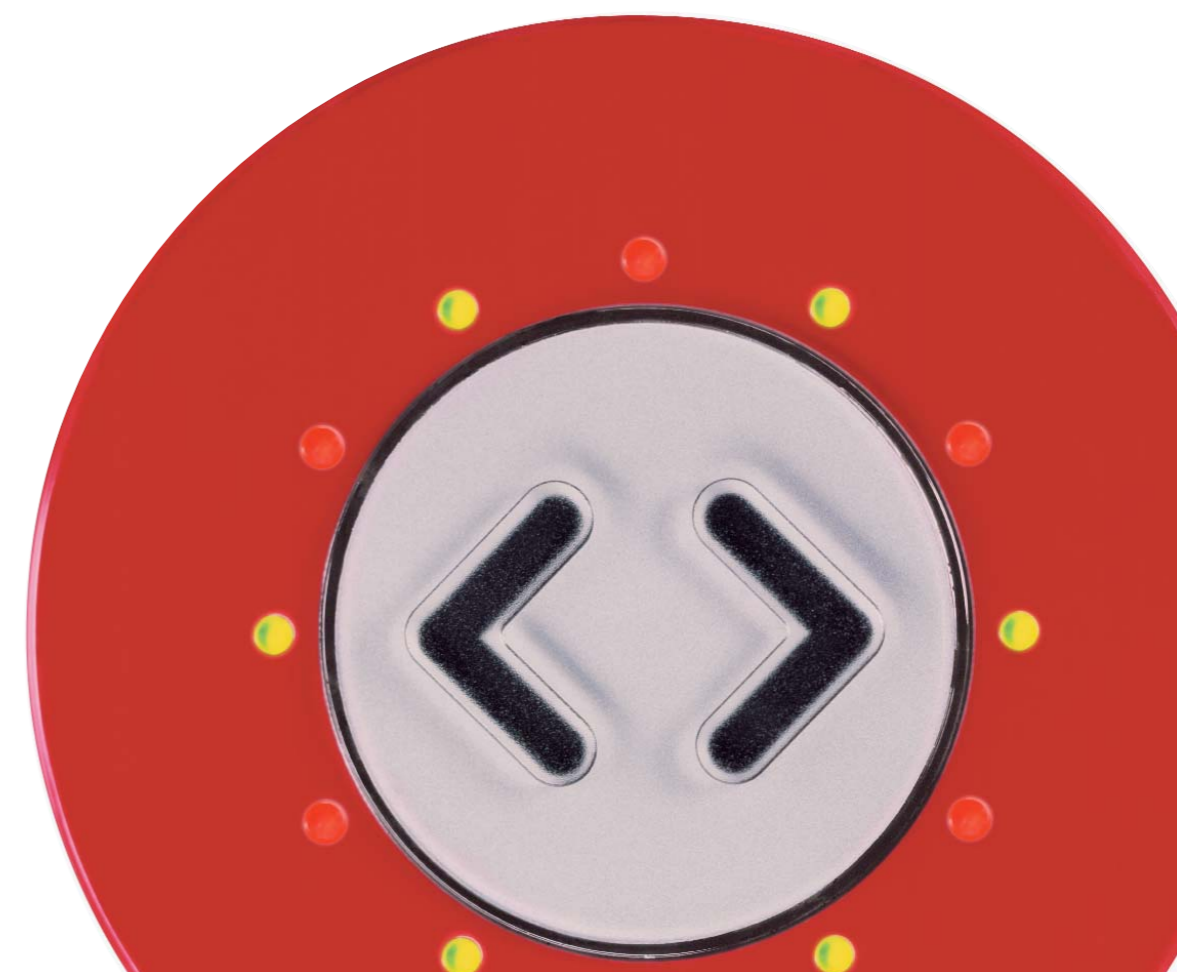

page 7-13

MP electromechanical short-stroke button
ESCHA-switching principle

One-part, switch housing, compact, robust, durable

Mounting-hole 30 mm

-  IP67
-  Frost
-  Hal

page 14-27

PK electromechanical short-stroke button
ESCHA-switching principle

One-part, switch housing, compact, robust, durable

Embedded mounting for speeds up to 450 km/h

Outer diameter Ø 87 mm

-  IP67
-  Frost
-  Acoustic
-  Glove
-  µP
-  Hal



Features

Dust- and waterproof according to IP67

No freezing of switching elements | frost-proof up to -40°C

Optional acoustic signals

Tactile surface structure

Microprocessorcontrolled

Halogen-free connecting cable

-  IP67
-  Frost
-  Acoustic
-  Glove
-  µP
-  Hal

page 28-41

CK electromechanical short-stroke button in stainless steel housing

Extra large touch surface

Tactile and acoustic check-back signal

Outer diameter Ø 100 mm

-  IP67
-  Frost
-  Acoustic
-  Glove
-  µP
-  Hal

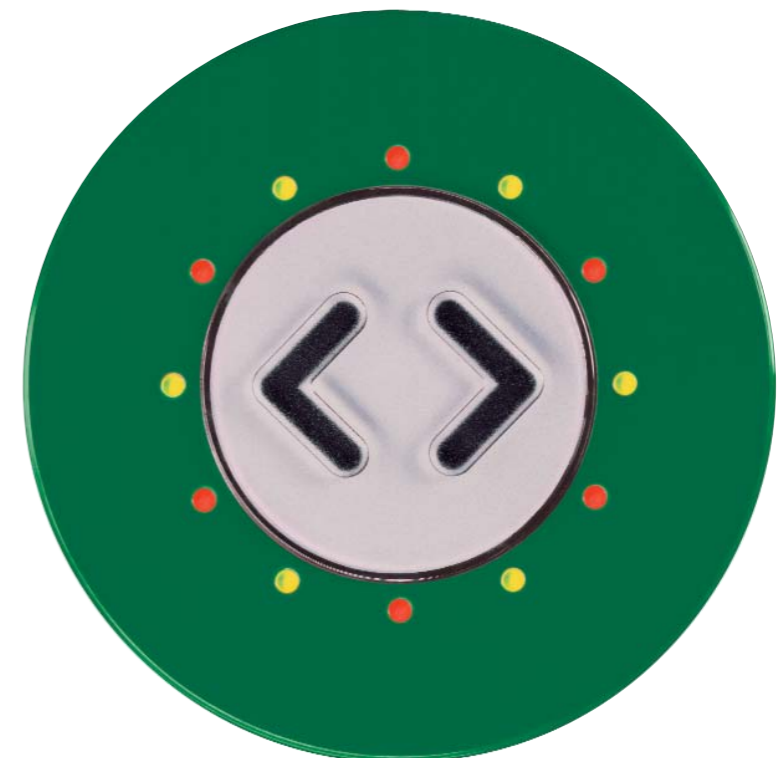

Nominal voltages 24V, 36V, 72V, 110V

Switching functions page 9

Colours of inner-ring page 12

Colours of fixing-ring page 42–43

Connectors page 44–45

MP Safe switching in smallest space under extreme conditions.

The ESCHA-switching principle is based on a hermetically sealed one-part switch housing, operates wear-resistant, independent of temperature, dust or humidity. The MP is weather-proof, suitable for washing-plants and resistant to conventional detergents.

Stand-by- and switching-mode display are effected by 4 LEDs in different colour combinations.

The mounting hole for the smallest ESCHA short-stroke button is 30 mm.

MP Mounting variants | page 10–11



MP30
Back-sided mounting

with milled nut

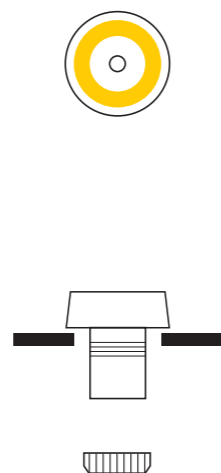

MP30 T
Button with timer function

in all mounting variants available

MP31
Back-sided mounting

with milled nut and compression spring limiting propeller thrust for thin walls

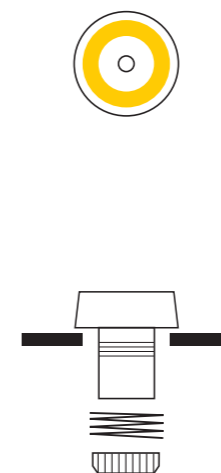

MP32
Front-sided mounting
with Fixingring

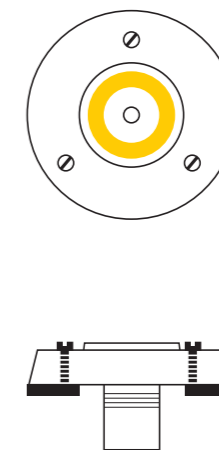

MP33
Front-sided mounting
with Adapterplate

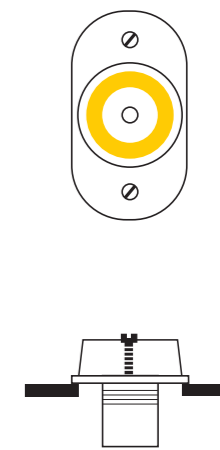

Nominal voltage	24 VDC, 36 VDC, 72 VDC, 110 VDC ± 30%
Switching current	approx. 200 mA
Closed-circuit current	approx. 10 mA (without LEDs)
Switching principle	One-part, hermetically sealed switch housing with multi-point contact and airpressure compensation system, back-end electronics, output signal PNP(NO), short-circuit proof, reverse polarity protection, button debouncing, switching-impulse length corresponding to activation period, min. 500ms

LED-variants	
MP30, MP31, MP32, MP33 Standard	3 LED stand-by display + 1 LED confirm display 3x green + 1x red; 3x red + 1x green others on request
MP30T Standard	stand-by display 1 LED 1x red others on request

Operating temperature	-40°... +80°C
Storage temperature	-40°... +95°C

Life cycle 7 Mio. Switching cycles

Activation force 7.5... 9N

Switching path 0.15 mm

Materials	Switch housing	PC, UV stabilized
	Contacts	CuZn, gold-plated
	Sealing	NBR
	Milled nut	PA6 GF
	Fixing ring	POM
	Adapterplate	V2A, powder-coated
	Cable	PUR, halogen-free

Standards Tests	
Protection degree	Front-sided IP67, according IEC 60529 Back-sided IP60, according IEC 60529
Mechanic- Dynamic- strength	according to IEC 61373 and EN50155
Climate- Corrosion-resistance	according to EN50155
Inflammability degree	S1 according DIN5510
High-voltage strength	according IEC60077-1
Approvals	EWG Type approval (Kraftfahrtbundesamt e1) GOST-R

Switching function | Connectivity configuration

	0V	+Vcc	output	LED_1*
MP30, MP31, MP32, MP33 Function 1 (3-wire) 3 LED stand-by at power-on +Vcc 1 LED confirm activation	blue	brown	black	
Function 2 (4-wire) 3 LED stand-by separately controlled 1 LED confirm activation	blue	brown	black	white
MP30T Function 1 (3-wire) 1 LED stand-by at power-on +Vcc confirm: LED off, switch on actuator (e.g. solenoid valve) switching period programmable	blue	brown	black	

*LED_1: stand-by display

Dimensions

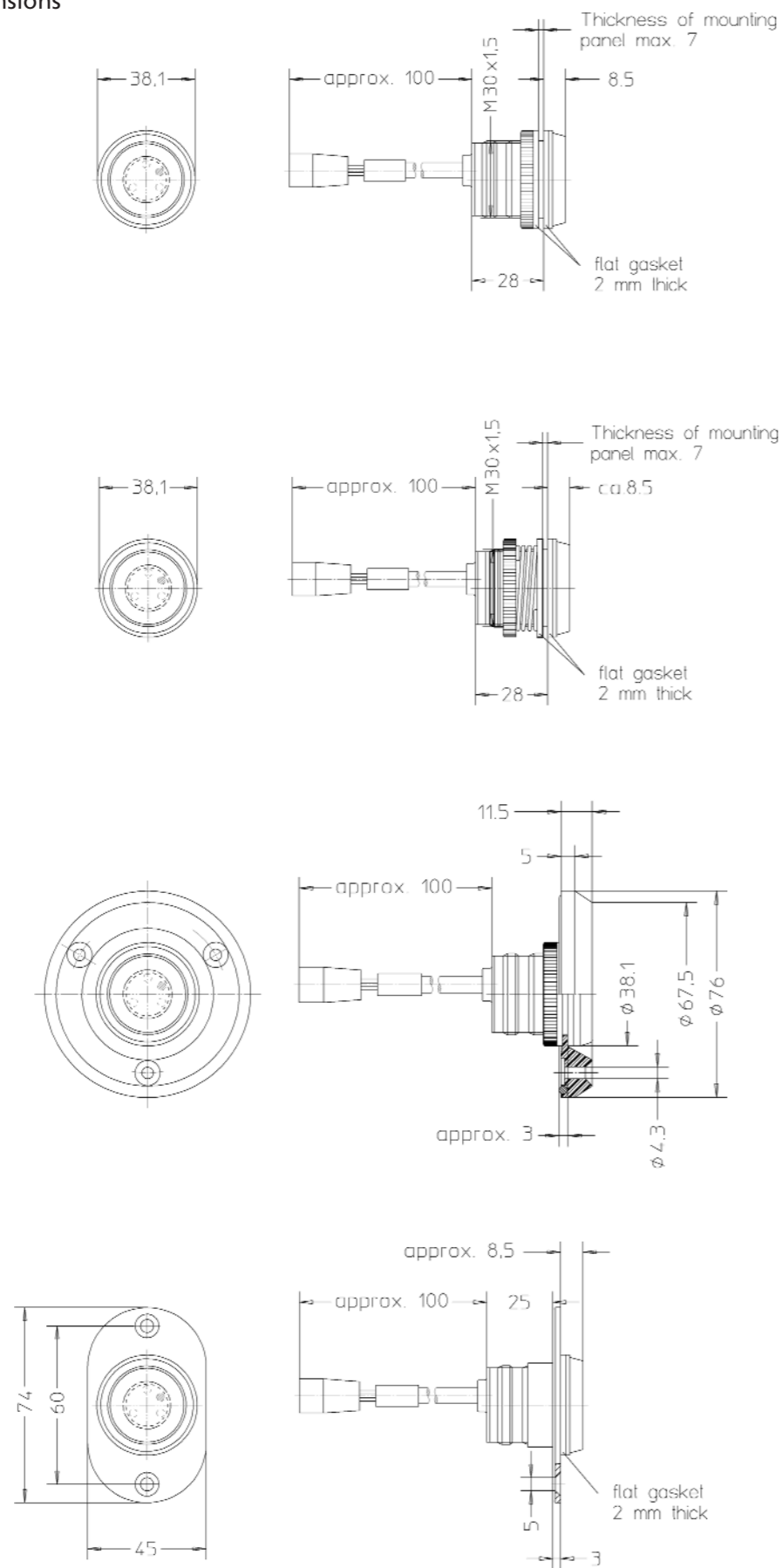

Mounting sections | Holes

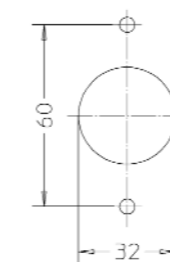
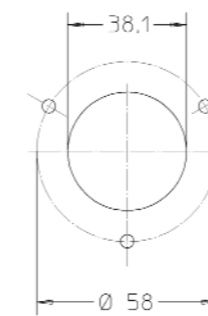
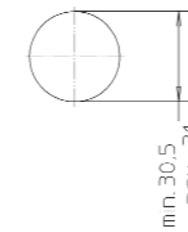
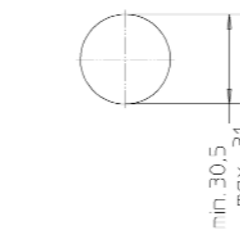

MP30 One-hole mounting, front-sided insertion of button, single screwing with milled nut on back-side

MP31 One-hole mounting, front-sided insertion of button, single screwing with milled nut on back-side, compression spring limiting propeller thrust for thin walls

MP32 complete front-sided mounting with fixing-ring, fixing by three screws (not included in scope of delivery)

MP33 complete front-sided mounting with robust adapterplate of powder-coated stainless steel, for very narrow mounting positions, fixing by two screws (not included in scope of delivery)



Light ivory
similar to RAL1015



Traffic green
similar to RAL6024

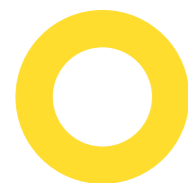

Traffic yellow
similar to RAL1023



Traffic grey A
similar to RAL7042



Pure orange
similar to RAL2004



Traffic grey B
similar to RAL7043



Traffic red
similar to RAL3020

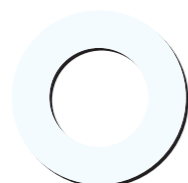

Traffic white
similar to RAL9016



Traffic blue
similar to RAL5017

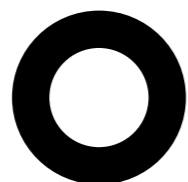

Traffic black
similar to RAL9017



Capri blue
similar to RAL5019



MP30T
Pictogram: water flow
Traffic blue
similar to RAL5017



The colours shown here are no RAL-colours.
Please use standard RAL-range for exact colour
selection.

Please contact us for other inner-ring colours,
texts on inner-ring or pictograms.

Colour selection of fixing-rings and adapter-
plates for MP32 and MP33 can be seen on
page 42 and 43.

MP Inquiry | So that you will not forget anything, simply mark with a cross and send us a
fax or go to internet Fax +49 2353 66796-99 | www.escha-tsl.de/anfragekompass

Mounting variants | page 10-11

MP30 MP31 MP32 MP33

Nominal voltage | page 8

24V 36V 72V 110V

LED-variants | page 8

Special LED: _____ 3gn+1rd 3rd+1gn

Switching function | page 9

MP30, MP31, MP32, MP33: fct.1 fct.2 MP30T

Colour inner-ring | page 12

RAL _____ Special colour: _____

Colour fixingring /adapterplate (MP32/MP33) | page 42-43

RAL _____ Special colour: _____

Connector (Standard cable length approx. 100mm) | page 44-45 without plug (2m cable)

Type-No.: _____ Special connector: _____

Special length: _____ Special cable: _____

Your data

Name: _____

Company: _____

Address: _____

Phone: _____

E-mail: _____

Nominal voltages 24V, 36V, 72V, 110V, 24V-110V

Switching functions page 16-19

Pictograms page 24-26

Colours page 42-43

Connectors page 44-45

PK one button – endless variants, combined out of different switching functions, touch surfaces and fixingrings, five mounting variants and endless colours and pictograms.

Create your specific button!

The ESCHA-switching principle, based on a hermetically sealed one-part switch housing, operates wear-proof, independent of temperature, dust or humidity.

The PK has been used on busses, trams and high-speed trains for many years.

PK Mounting variants | page 21-23

1-sided function Front side mounting	Screw mounting
1-sided function Front side mounting	Back-wall mounting with fixingclaws
1-sided funktion Front side mounting	Screwless with Zentraflexring
1- 2-sided function Both side mounting	Glass mounting

PK variants



**PK21
PK22
PK23
PK28**

Highend version

6+6 LED for stand-by- and confirm display

Optionally with acoustic check-back signal

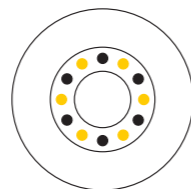

**PK25
PK26
PK27
PK29**

Economy version

4 LED stand-by display

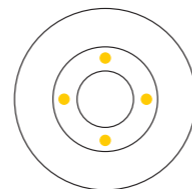

PK Fixing variants and touch surface versions



**PK21
PK25**

Fixingring: flat
Screws: visible
Touch surface: flat
Pictograms: flat

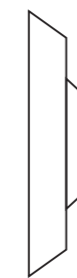

**PK28
PK29**

Fixingring: flat
Screws: visible
Touch surface: projected
Pictogram: tactile



**PK22
PK26**

Fixingring: projected
Screws: covered
Touch surface: flat
Pictograms: flat



**PK23
PK27**

Fixingring: projected
Screws: covered
Touch surface: projected
Pictogram: tactile

Nominal voltage	24 V _{DC} , 36 V _{DC} , 72 V _{DC} , 110 V _{DC} , 24 – 110 V _{DC} ± 30%
Switching current	approx. 200 mA
Closed-circuit current	approx. 10 mA (without LEDs)
Switching principle	One-part, hermetically sealed switch housing with multi-point contact and airpressure compensation system, back-end electronics, output signal PNP (NO), short-circuit proof, reverse polarity protection, button debouncing, switching-impulse length corresponding to activation period, min. 500ms, optionally microprocessor controlled with integrated switch powersupply for multivoltage range

LED-variants	6 LED stand-by display + 6 LED confirmation display optional: 6 LED stand-by display + 5 LED confirmation display + 1 LED out-of-order display
Standard	6xgreen+6xred; 6xgreen+5xred+1xyellow others on request

Acoustics (optional)	Orientation-, confirm-, or warn sound individually programmable duration- or interval sound frequency range of 1...5 kHz, sound pressure max. 53 dBA
-----------------------------	--

Operating temperature	-40°... +80°C
------------------------------	---------------

Storage temperature	-40°... +95°C
----------------------------	---------------

Life cycle	7 Mio. switching cycles
-------------------	-------------------------

Activation force	7.5... 9 N
-------------------------	------------

Switching path	0.15 mm
-----------------------	---------

Materials	Switch housing	PC, UV stabilized
	Contacts	CuZn, gold-plated
	Sealing dome	EPDM
	Fixingring	PA6GF15
	Zentraflexring	NBR
	Cable	PUR, halogen-free

Standards Tests	
Protection degree	Front-sided IP67, according IEC 60529 Back-sided IP67, according IEC 60529
Mechanic- Dynamic-strength	according to IEC 61373 and EN50155
Climate- Corrosion-resistance	according to EN50155
Inflammability degree	S1 according DIN5510
High-voltage strength	according IEC60077-1
Approvals	EWG Type approval (Kraftfahrtbundesamt e1) DB-standard BN65074 Buttons for boarding doors GOST-R

Switching function | Connectivity configuration

	0V	+V _{CC}	output	LED_1*	LED_2*	sound
Function 1 (3-wire) 6 LED stand-by at power-on +V _{CC} 6 LED confirm at activation	blue	brown	black			
Function 2 (4-wire) 6 LED stand-by separately controlled 6 LED confirm at activation	blue	brown	black	white		
Function 3 (5-wire) 6 LED stand-by separately controlled 6 LED confirm separately controlled	black	white	brown	blue	grey	
Function 4 (6-wire) 6 LED stand-by separately controlled 6 LED confirm separately controlled separately controlled acoustics	yellow	orange	black	brown	red	green

Function 5
Individual programming of output signal, LED function, separate inputs and acoustics

*LED_1: Stand-by display
LED_2: Confirm display

Nominal voltage	24 V _{DC} , others on request ±30%
Switching current	approx. 50mA
Closed-circuit current	approx. 10mA (without LEDs)
Switching principle	One-part, hermetically sealed switch housing with multi-point contact and airpressure compensation system, back-end electronics, output signal PNP(NO), switching-impulse length corresponding to activation period, min. 500ms

LED-variants	4LED stand-by display
Standard	4xgreen others on request

Operating temperature	-40°... +80°C
------------------------------	---------------

Storage temperature	-40°... +95°C
----------------------------	---------------

Life cycle	7 Mio. switching cycles
-------------------	-------------------------

Activation force	7.5... 9N
-------------------------	-----------

Switching path	0.15mm
-----------------------	--------

Materials	Switch housing	PC, UV stabilized
	Contacts	CuZn, gold-plated
	Sealing dome	EPDM
	Fixingring	PA6GF15
	Zentraflexring	NBR
	Cable	PUR, halogen-free

Standards Tests	
Protection degree	Front-sided IP67, according IEC 60529 Back-sided IP67, according IEC 60529
Mechanic- Dynamic-strength	according to IEC 61373 and EN50155
Climate- Corrosion-resistance	according to EN50155
Inflammability degree	S1 according DIN5510
High-voltage strength	according IEC60077-1

Switching function | Connectivity configuration

	0V	+V _{CC}	output	LED_1*	LED_2*	sound
Function 2 (4-wire) 4LED stand-by separately controlled no confirmation	blue	brown	black	white		

*LED_1: Stand-by display
LED_2: Confirm display

Dimensions

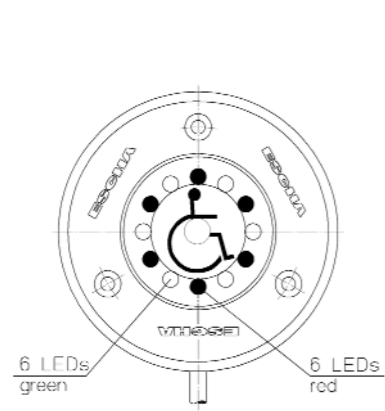

Ø 65mm-hole circle

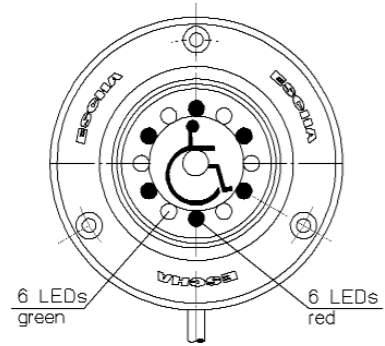
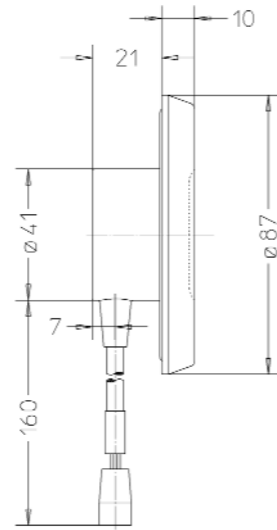

Ø 76mm-hole circle

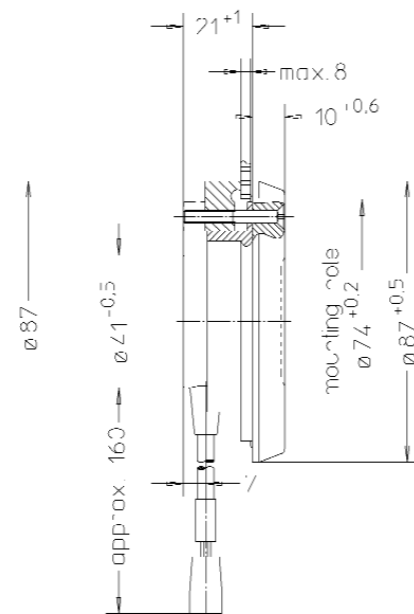
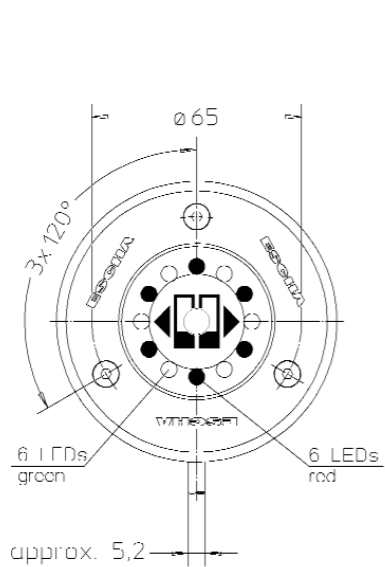
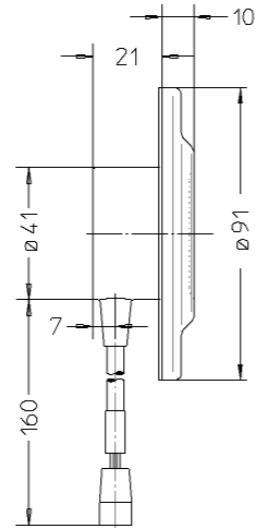

Mounting sections | Holes



Position A

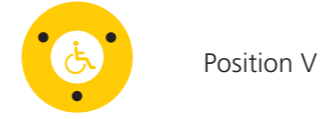

Position V

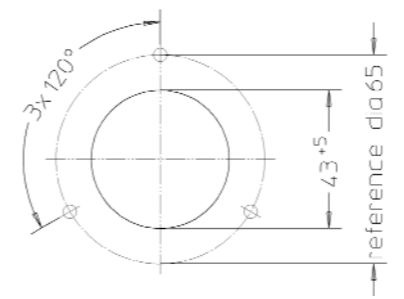

3x120° in Ø 65mm-hole-circle

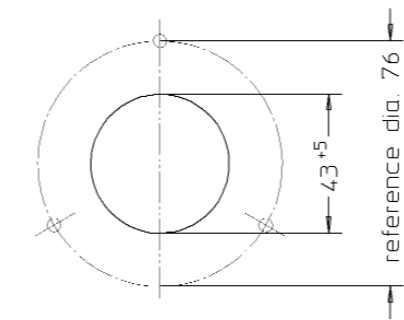

3x120° in Ø 76mm-hole-circle

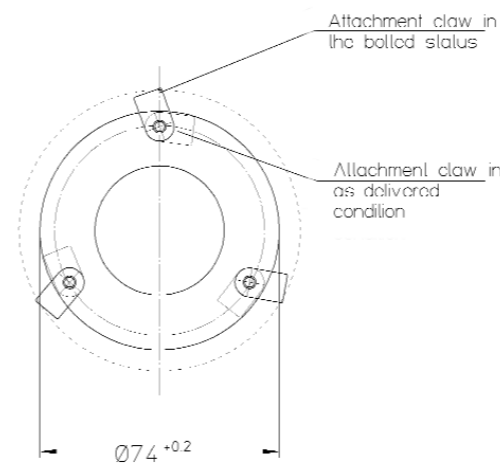

Back-wall mounting with fixing claws

Easy front mounting, fixing by self-adjustable fixing claws, different wall thicknesses are easily compensated, screws included in scope of delivery

Dimensions

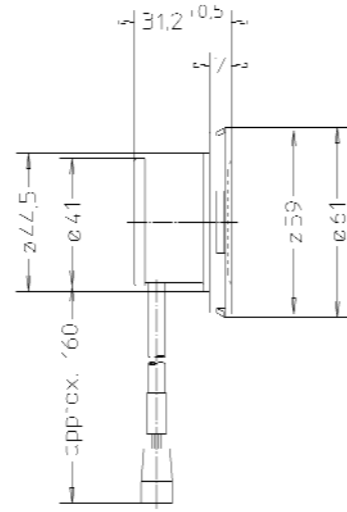
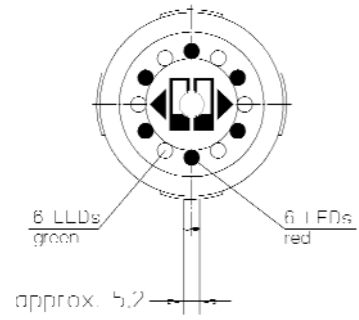

Mounting sections | Holes

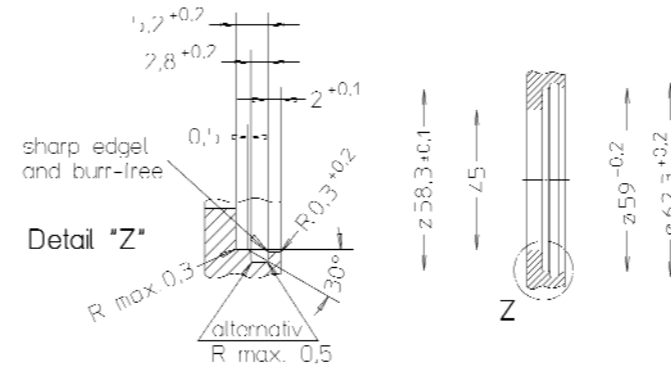

Without screws by Zentraflexring

Flush-mounting, time-ried on high-speed trains up to 450km/h

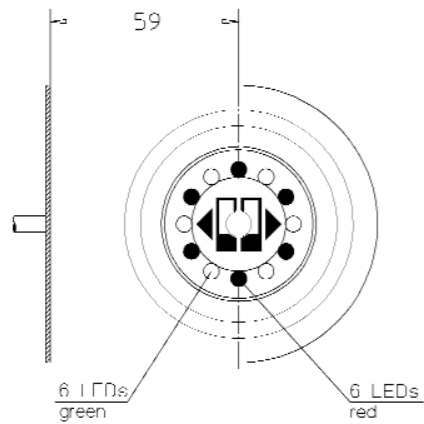
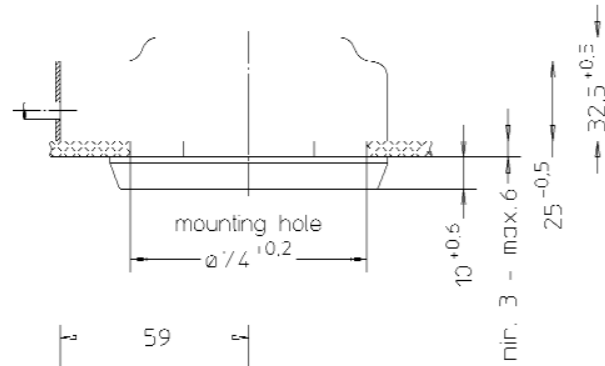
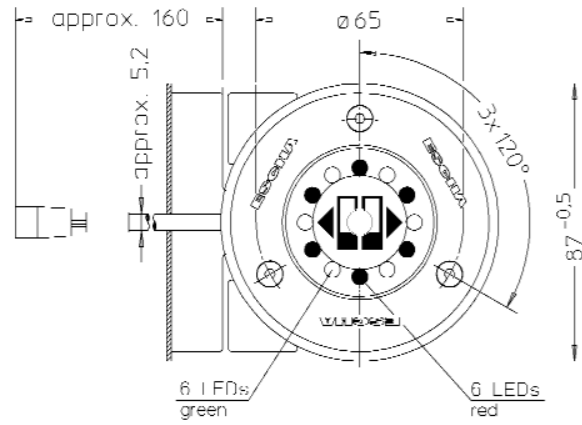

Push-button, inner side-view, 2-sided function

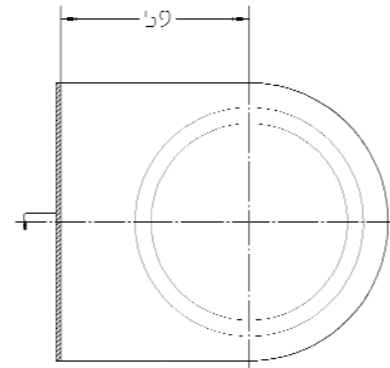

Push-button, inner side-view, 1-sided function

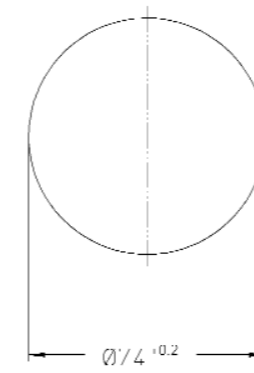

Glass mounting 1- | 2-sided

Easy glassdoor mounting, button is held by a fixingring during mounting so that inner-housing cover and outer fixingring can be easily screwed together (screws included in scope of delivery), adaptation to different door profiles possible Available angles: 0° | 10° | 25°

Arrows OPEN

	PK_B10 ye: RAL1023 Arrows OPEN bk: RAL9017		PK_B41 ye: RAL1023 Arrows OPEN bk: RAL9017		PK_B22 rd: RAL3020 Arrows OPEN wh: RAL9016
---	--	---	--	--	--

	PK_B9 bu: RAL5017 Arrows OPEN silv: RAL9006		PK_B17 silv: RAL9006 Arrows OPEN bu: RAL5017		PK_B8 gn: RAL6024 Arrows OPEN silv: RAL9006
---	---	---	--	--	---

	PK_B38 gn: RAL6024 Arrows OPEN wh: RAL9016		PK_B45 gn: RAL6024 Arrows OPEN wh: RAL9016		PK_B20 gr: RAL 7042 Arrows OPEN bk: RAL9017
---	--	---	--	--	---

Arrows OPEN tactile

	PK_B66 ye: RAL1023 Arrows OPEN tactile bk: RAL9004		PK_B42 gn: RAL6024 Arrows OPEN tactile bk: RAL9004		PK_B25 silv: RAL9006 Arrows OPEN tactile bk: RAL9004
--	--	--	--	---	--

	PK_B56 bk: RAL9004 Arrows OPEN tactile wh: RAL9016
--	--

Arrows CLOSED



	PK_B39 rd: RAL3020 Arrows CLOSED wh: RAL9016		PK_B46 rd: RAL3020 Arrows CLOSED wh: RAL9016		PK_B57 bu: RAL5017 Arrows CLOSED silv: RAL9006
---	--	---	--	--	--

Arrows CLOSED tactile



	PK_B43 rd: RAL3020 Arrows CLOSED tactile bk: RAL9004		PK_B29 silv: RAL9006 Arrows CLOSED tactile bk: RAL9004
---	--	--	--

Arrows OPEN + text

	PK_B67 ye: RAL1023 Arrows OPEN + text bk: RAL9017		PK_B7 rd: RAL3020 Arrows OPEN + text silv: RAL9006		PK_B15 rd: RAL3003 Arrows OPEN + text silv: RAL9006
---	---	---	--	--	---

	PK_B54 rd: RAL3020 Arrows OPEN + text silv: RAL9006		PK_B5 bu: RAL5017 Arrows OPEN + text silv: RAL9006		PK_B24 gn: RAL6024 Arrows OPEN + text wh: RAL9016
---	---	---	--	---	---

	PK_B31 gn: RAL6024 Arrows OPEN + text wh: RAL9016		PK_B24 gn: RAL6024 Arrows OPEN + text silv: RAL9006		PK_B49 gr: RAL7042 Arrows OPEN + text wh: RAL9016
---	---	---	---	---	---



	PK_B32 rd: RAL3020 Arrows CLOSED + text wh: RAL90167		PK_B6 bu: RAL5017 Arrows CLOSED + text silv: RAL9006		PK_B55 gn: RAL 6024 Arrows CLOSED + text silv: RAL9006
---	--	---	--	---	--

Arrows OPEN + door



	PK_B13 ye: RAL1023 Arrows OPEN + door bk: RAL9017		PK_B16 rd: RAL3020 Arrows OPEN + door silv: RAL9006		PK_B51 bu: RAL5017 Arrows OPEN + door silv: RAL9006
--	---	--	---	--	---



	PK_B40 gn: RAL6024 Arrows OPEN + door silv: RAL9006
---	---

Arrows OPEN + Pictogram

	PK_B14 ye: RAL1023 Arrows OPEN + pram bk: RAL9017		PK_B421 ye: RAL1023 Arrows OPEN pram/wheelchair bk: RAL9017		PK_B52 bu: RAL5017 Arrows OPEN pram/wheelchair wh: RAL9016
---	---	---	---	---	--

Pictograms

	PK_B47 ye: RAL1023 wheelchair bk: RAL9017		PK_B2 bu: RAL5017 wheelchair wh: RAL9016		PK_B4 silv: RAL9006 wheelchair bu: RAL5017
---	---	---	--	---	--

	PK_B18 ye: RAL1023 pram bk: RAL9017		PK_B23 bu: RAL5017 pram wh: RAL9016		PK_B1 silv: RAL9006 pram bu: RAL5017
---	---	---	---	---	--

Picto-grams



PK_**B19**
silv: RAL9006
Bike
gn: RAL6024



PK_**B30**
gr: RAL7035
Hand
gn: RAL6024



PK_**B11**
ye: RAL1023
Info
bk: RAL9017



PK_**B12**
rd: RAL3020
Alarm bell
wh: RAL9016



PK_**B48**
bk: RAL9017
Signal
wh: RAL9016

Text



PK_**B34**
rd: RAL3020
text
silv: RAL9006



PK_**B33**
gn: RAL6024
text
silv: RAL9006



PK_**B37**
rd: RAL3020
text
wh: RAL9016



PK_**B57**
gn: RAL6024
text
wh: RAL9016

blank



PK_**B50**
ye: RAL1023



PK_**B3**
gold

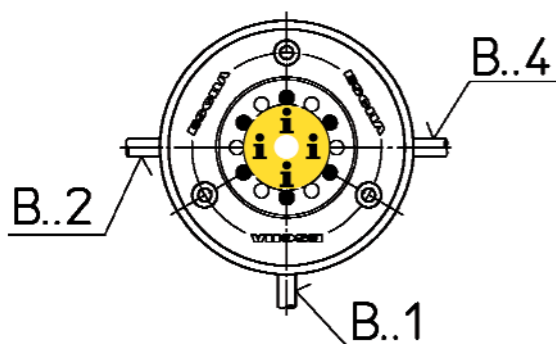

The RAL-colours can only be slightly achieved. Deviations are permissible. The colours shown here are no RAL-colours. Please use standard RAL-range for exact colour selection.

Please observe position of cable in relation to pictogram. Order example PK21, Pictogram info, cable on right side: PK21.B11.4.

The illustrated view corresponds to outer side of vehicle. The pictogram on the inner side of vehicle is accordingly mounted mirror-inverted on the vertical axis.

ESCHA-short-stroke Push-Buttons were developed for operation on road- and rail vehicles.

ESCHA-short-stroke Push-Buttons described here are exposed to outdoor- and thus extreme conditions: cold, heat (sun), repeated temperature changes, humidity (spray water), dirt, chemicals etc.

Furthermore, special electrical and mechanical requirements are realized: function reliability, avoiding weather-related impinging, light signal, temperature independent- as well as constantly low activation force, antiblocking of the switching- or activation elements, impact and vibration resistance, operating reliability, long life and maintenance-free.

Design features

The buttons **MP** and **PK** operate on the same principle which consists of these main design features.

- Fully closed, one-part switch housing with an integrated elastic and transparent activation surface which does not need any sealing elements
- Use of high-grade plastics
- Hermetically closed switch chamber with airpressure-compensation system
- Mechanical multi-point contact
- Elastic decoupling of switch housing from fixing
- Integrated electronics, optionally microprocessorcontrolled (PK-range)

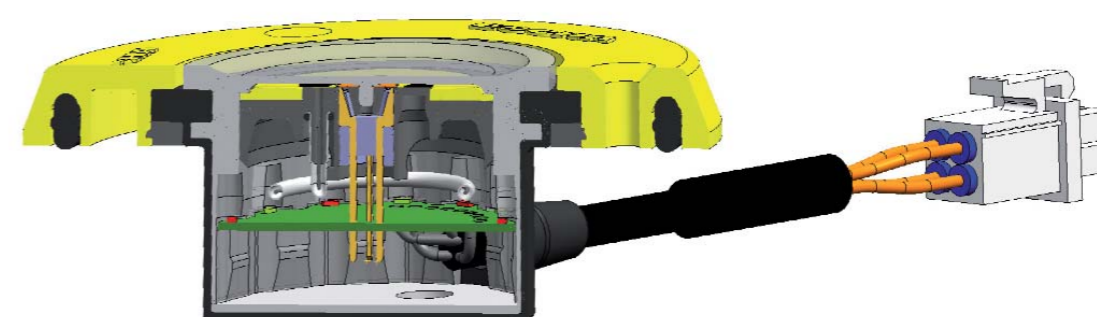

The ESCHA-switching principle

PK Inquiry | So that you will not forget anything, simply mark with a cross and send us a fax or go to internet. Fax +49 2353 66796-99 | www.escha-tsl.de/anfragekompass

Button variants | page 16-17

Highend

PK21 PK22 PK23 PK28

Nominal voltage | page 16

24V-110V 24V 36V 72V 110V

LED-variants | page 16

6gn+6rd 6gn+5rd+1ye Special LED: _____

Switching function | page 17

fct.1 fct.2 fct.3 fct.4 fct.5

Acoustic | page 16

Confirm: _____ kHz Intervall: _____ Hz none

Orientation: _____ kHz Intervall: _____ Hz none

others: _____ kHz Intervall: _____ Hz

Mounting variants | page 20-23

Screw mounting Back wall with claws Zentraflexring

Glass mounting 1-sided Glass mounting 2-sided

Pictogram.cable outlet | page 24-26

B _____ Special pictogram: _____

Fixingring colour | page 42-43

RAL _____ Special colours: _____

Connector (Standard cable length approx. 160mm) | page 44-45 without plug (2m cable)

Type-No.: _____ Special connector: _____

Special length: _____ Special cable: _____

Your data

Name: _____
 Company: _____
 Address: _____

 Phone: _____
 E-mail: _____

PK Inquiry | So that you will not forget anything, simply mark with a cross and send us a fax or go to internet. Fax +49 2353 66796-99 | www.escha-tsl.de/anfragekompass

Button variants | page 18-19

Economy

PK25 PK26 PK27 PK29

Nominal voltage | page 18

24V Special voltage: _____

LED-variants | page 18

4gn Special LED: _____

Mounting variants | page 20-23

Screw mounting Back wall with claws Zentraflexring

Glass mounting 1-sided Glass mounting 2-sided

Pictogram.cable outlet | page 24-26

B _____ Special pictogram: _____

Fixingring colour | page 42-43

RAL _____ Special colours: _____

Connector (Standard cable length approx. 160mm) | page 44-45 without plug (2m cable)

Type-No.: _____ Special connector: _____

Special length: _____ Special cable: _____

Your data

Name: _____
 Company: _____
 Address: _____

 Phone: _____
 E-mail: _____

Nominal voltages 24V, 110V, 24V-110V

Switching functions page 33

Pictograms page 38-40

Colours page 42-43

Connectors page 44-45

CK vandalism-proof stainless steel button in extremely flat version.

The extra large touch surface of 23 cm², tactile surface structure, optical and acoustic check-back signals are specially designed to meet the requirements of the handicapped.

Microprocessors provide for the programming of individual switching functions.

The buttons are dust- and water-proof according to IP67. The stainless steel surface is resistant to aggressive detergents and graffiti removers.

CK Mounting variants | page 34-37

1-sided function Front side mounting	Screw mounting with fixing plate
1-sided function Front side mounting	Back-wall mounting with fixing claws
1-sided function Front side mounting	Screwless rubbering mounting
1-sided function Back side mounting	Cover housing
2-sided function Both side mounting	Glass mounting
2-sided function Both side mounting	Double-wall mounting

CK LED-variants | page 32



	6+6 LED alternating controlled
	6+6 LED semi-circular controlled
	12x1 LED Individually controlled, free colour selection, RGB-LEDs possible

CK variants



Touch surface:
Pictogram:

CK70

CK80

flat
flat



CK71

CK81

projected
with protective cap



CK72

CK82

projected
tactile, with
protective cap

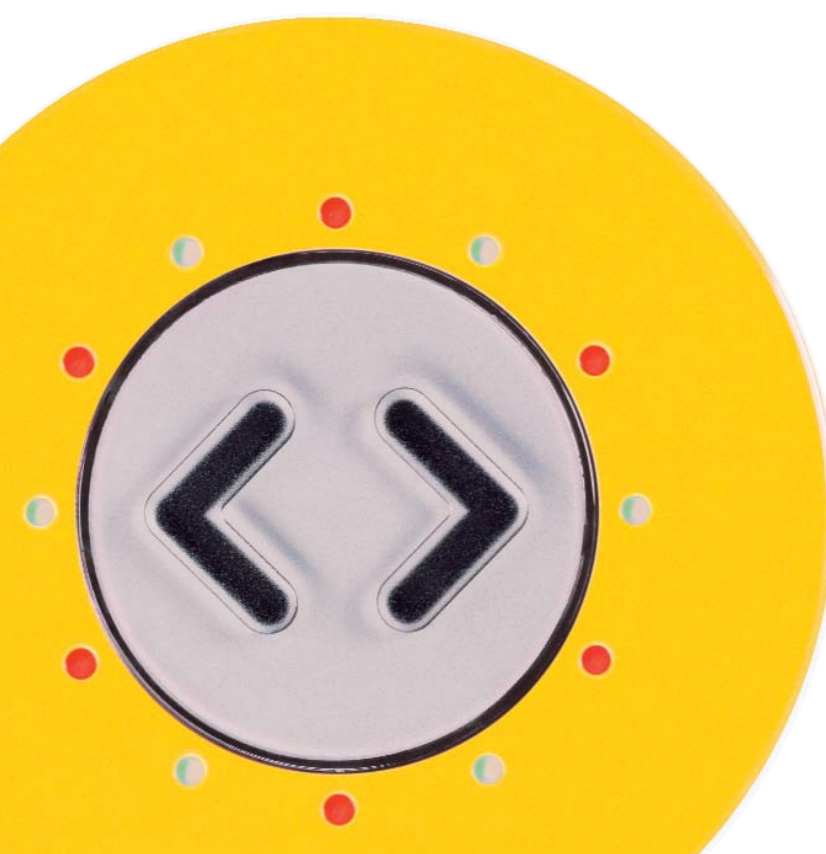
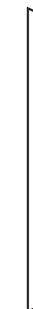

Nominal voltage	24 V _{DC} , 110 V _{DC} , 24 –110 V _{DC} ±30%	
Switching current	approx. 200mA	
Closed-circuit current	approx. 10mA (without LEDs)	
Switching principle	Electromechanical short-stroke button, back-end electronics, output signal PNP (NO), short-circuit proof, overvoltage- and reverse polarity protection, button debouncing, switching-impulse length corresponding to activation period, min. 500ms, optionally microprocessorcontrolled with integrated switch power-supply for multivoltage range	
LED-variants	6 LED stand-by display+6LED confirmation display alternating, semi-circular or individually controlled	
Standard	alternating 6xgreen+6xred others on request, RGB-LED possible	
Acoustics (optional)	Orientation-, confirm-, or warn sound individually programmable duration- or interval sound frequency range of 1...5kHz, sound pressure max. 53dBA	
Operating temperature	–40°... +80°C	
Storage temperature	–40°... +95°C	
Life cycle	7 Mio. switching cycles	
Activation force	7.5...9N	
Switching path	0.4mm	
Materials	Fixingring	V2A, powder-coated
	Fixing plate	PA6GF
	Contacts	CuZn, gold-plated
	Protective cap	PC, UV stabilized
	Cover housing	PA6GF15
	Distance ring	PA6GF15
	Sealing	NBR
	Cable	PUR, halogen-free

Standards Tests	
Protection degree	Front-sided IP67, according IEC 60529 Back-sided IP60, according IEC 60529
Mechanic- Dynamic-strength	according to IEC 61373 and EN50155
Climate- Corrosion-resistance	according to EN50155
Inflammability degree	S1 according DIN5510
High-voltage strength	according IEC60077-1
Approvals	EWG Type approval (Kraftfahrtbundesamt e1) GOST-R

Switching function | Connectivity configuration

	0V	+V _{CC}	output	LED_1*	LED_2*	sound
Function 1 (3-wire) 6 LED stand-by at power-on +V _{CC} 6 LED confirm at activation	blue	brown	black			
Function 2 (4-wire) 6 LED stand-by separately controlled 6 LED confirm at activation	blue	brown	black	white		
Function 3 (5-wire) 6 LED stand-by separately controlled 6 LED confirm separately controlled	black	white	brown	blue	grey	
Function 4 (6-wire) 6 LED stand-by separately controlled 6 LED confirm separately controlled separately controlled acoustics	yellow	orange	black	brown	red	green
Function 5 Individual programming of output signal, LED function, separate inputs and acoustics						

*LED_1: Stand-by display
LED_2: Confirm display

Dimensions

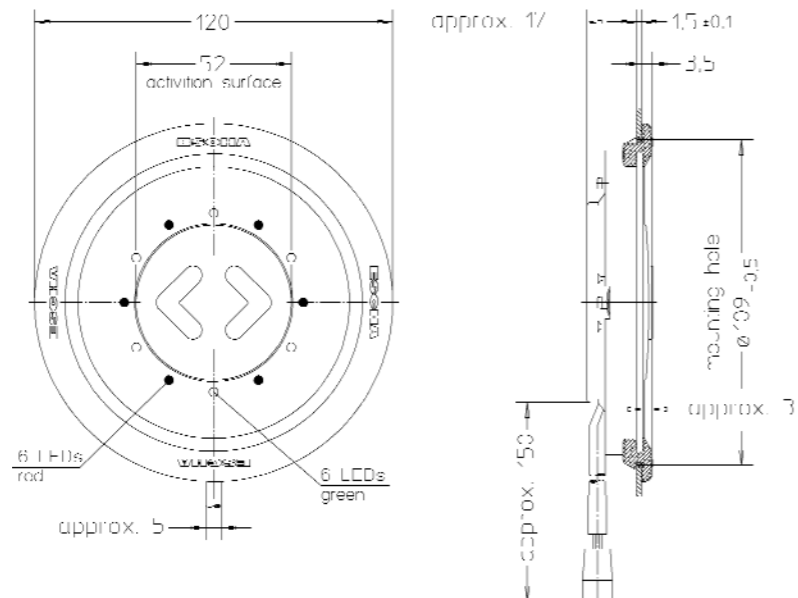
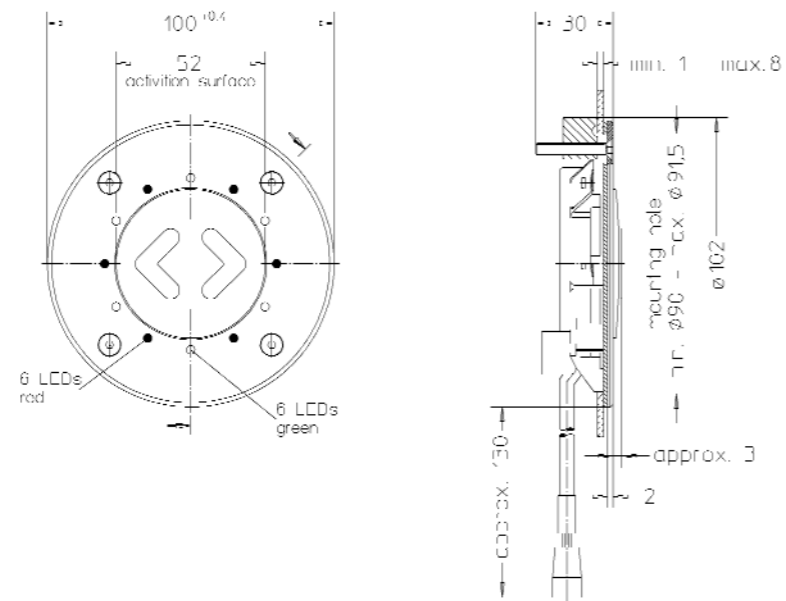
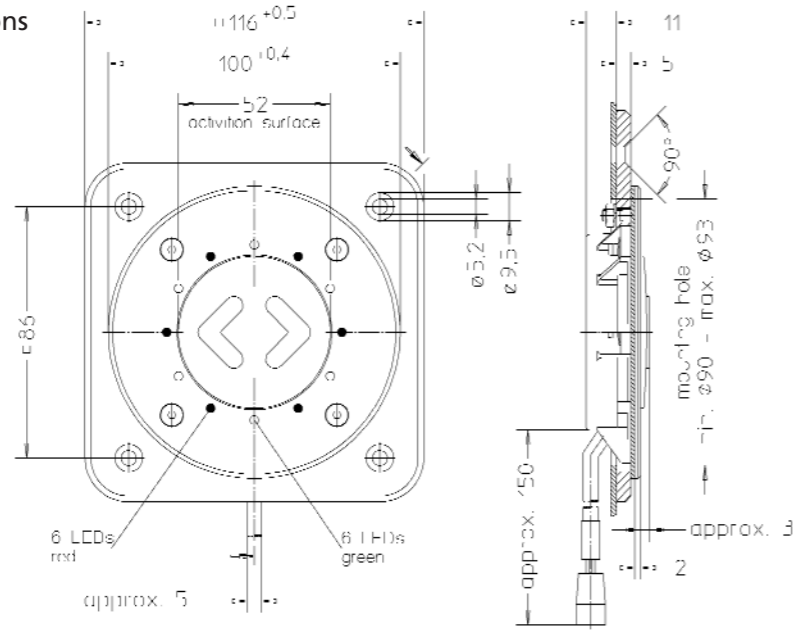

Mounting sections | Holes

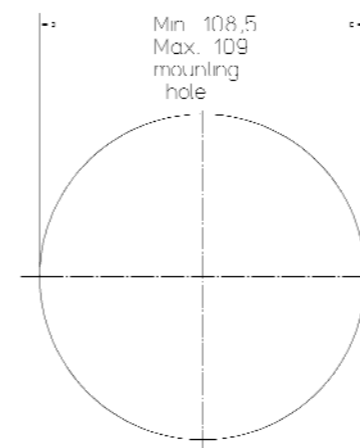
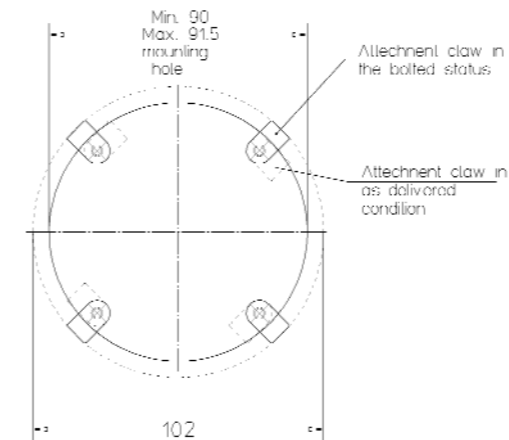
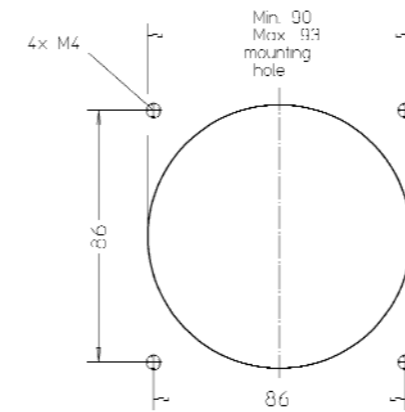

Screw mounting with fixing plate

Front-sided mounting with pre-mounted fixing plate, fixing by four screws (not included in scope of delivery), best for inner areas and extremely slight mounting depth

Back-wall mounting with fixing claws

Easy front mounting, fixing by self-adjusting fixing claws, different wall thicknesses are easily compensated, screws included in scope of delivery

Screwless rubbering mounting

Easy mounting with flexible ring of NBR, mounting ring provides for additional corner protection. Various mounting rings are available for wall thickness of 1.5mm and 3mm

Dimensions

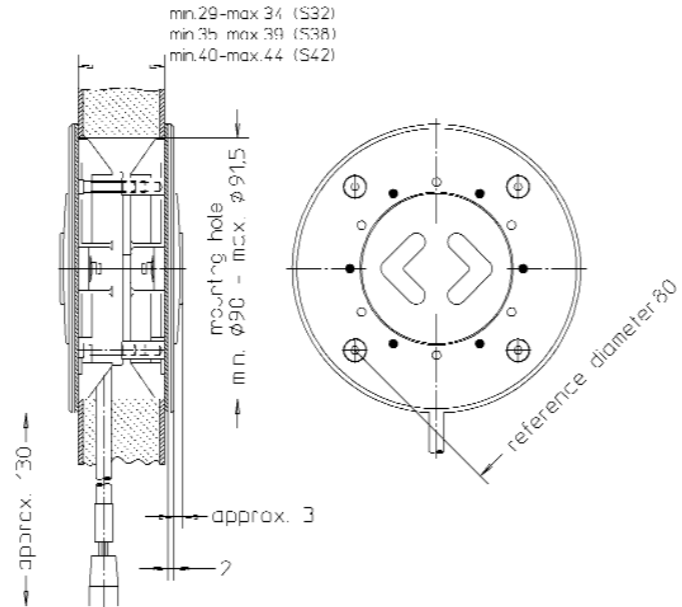
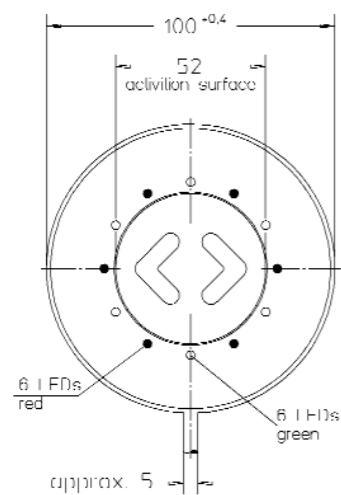
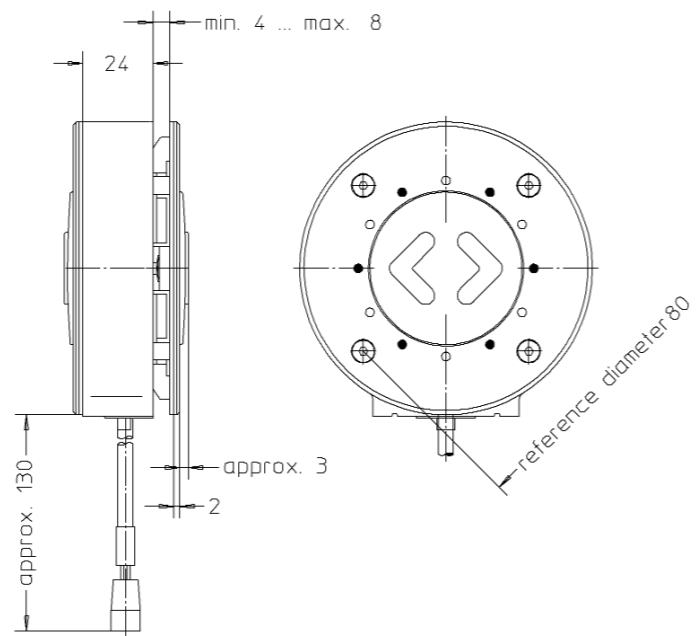
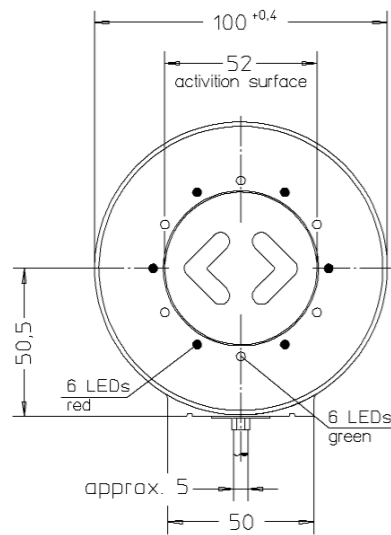
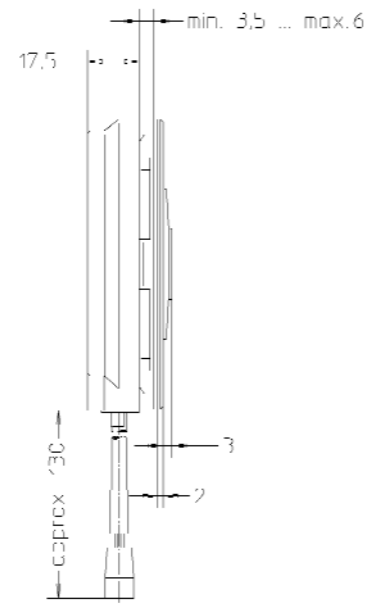
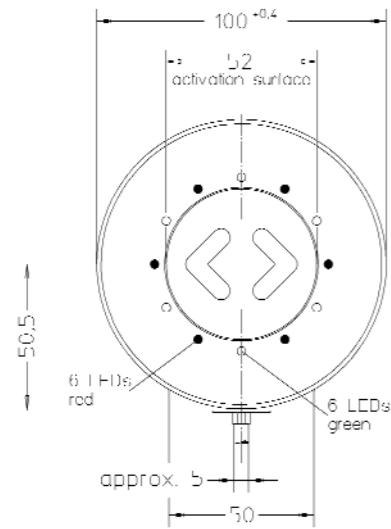

Mounting sections | Holes

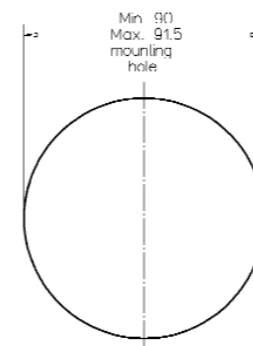
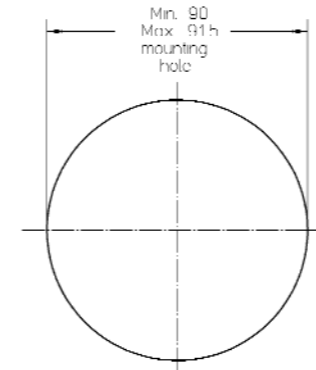

Cover housing Fixing from back side by cover housing and four screws (included in scope of delivery), invisible screws on front side, suitable for glass mounting, glass thickness 3.5 mm to 6 mm. Adaptation to different door profiles possible. Available angles: 0° | 6° | 10° | 25°

Glass mounting | 2-sided Easy mounting inner button and distance ring pre-mounted, outer button is connected with inner button by four screws (screws included in scope of delivery), adaptation to various door profiles by different distance rings possible, suitable for glass thickness of 4 mm to 8 mm, electrical connection of both buttons is without cable by an integrated connector with distance compensation. Adaptation to different door profiles possible. Available angles: 0° | 6° | 10° | 25°

Double-wall mounting | 2-sided Easy mounting, outer button connected with inner button by four screws (screws included in scope of delivery), distance from inner- and outer wall can be 29 mm to 44 mm, electrical connection of both buttons is without cable by an integrated connector with distance compensation.

Arrows OPEN

	CK_.B12 ye: RAL1023 Arrows OPEN bk: RAL9017		CK_.B9 ye: RAL1023 Arrows OPEN bk: RAL9017		CK_.A9 Alu, anodised gold:colour No.62 Arrows OPEN bk: colour No.12
---	---	---	--	--	--

Arrows OPEN tactile

	CK_.B35 ye: RAL1023 Arrows OPEN tactile bk: RAL9017		CK_.B42 rd: RAL3020 Arrows OPEN tactile wh: RAL9016		CK_.B46 gn: RAL6024 Arrows OPEN tactile wh: RAL9016
---	---	---	---	--	---

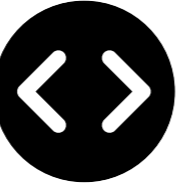
	CK_.B39 gn: RAL6024 Arrows OPEN tactile bk: RAL9017		CK_.B28 silv: RAL9006 Arrows OPEN tactile bk: RAL9017		CK_.B55 bk: RAL9017 Arrows OPEN tactile wh: RAL9016
---	---	---	---	--	---

Arrows CLOSED tactile

	CK_.B47 rd: RAL3020 Arrows CLOSED tactile wh: RAL9016		CK_.B29 silv: RAL9006 Arrows CLOSED tactile bk: RAL9017
--	---	---	---

Arrows OPEN + text

	CK_.B14 or: RAL2002 Arrows OPEN + text wh: RAL9016		CK_.B13 rd: RAL3020 Arrows OPEN + text silv: RAL9006		CK_.B22 rd: RAL3020 Arrows OPEN + text silv: RAL9006
---	--	---	--	--	--

	CK_.B5 bu: RAL5017 Arrows OPEN + text silv: RAL9006
--	---

Arrows CLOSED + text

	PK_.B6 bu: RAL5017 Arrows CLOSED + text silv: RAL9006
--	---

Arrows OPEN + door

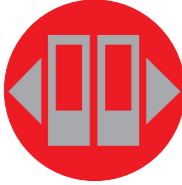
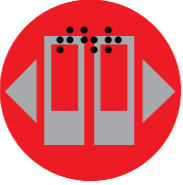
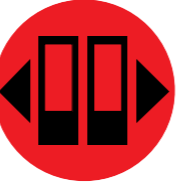
	CK_.B10 rd: RAL3020 Arrows OPEN + door silv: RAL9006		CK_.B25 rd: RAL3020 Arrows OPEN + door (braille) silb: RAL9006		CK_.B3 rd: RAL3020 Arrows OPEN + door bk: RAL9017
---	--	---	--	--	---

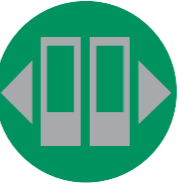

	CK_.B27 bl: RAL5017 Arrows OPEN + door silv: RAL9006		CK_.B26 gn: RAL6024 Arrows OPEN + door silv: RAL9006
---	--	---	--

	CK_.B8 ye: RAL1023 Arrows OPEN pram/wheelchair bk: RAL9017		CK_.B34 ye: RAL1023 Arrows OPEN wheelchair bk: RAL9017		CK_.B7 ye: RAL1023 Arrows OPEN pram bk: RAL9017
---	--	---	--	---	---

	CK_.B31 bu: RAL5017 Arrows OPEN pram/wheelchair wh: RAL9016
---	---

	CK_.B11 ye: RAL1023 wheelchair bk: RAL9017		CK_.B37 ye: RAL1037 wheelchair bu: RAL5022		CK_.B2 bu: RAL5017 wheelchair wh: RAL9016
--	--	--	--	--	---

	CK_.B4 gr: RAL7035 Hand gn: RAL6024		CK_.B53 bk: RAL9017 wheelchair wh: RAL9016		CK_.B20 bu: RAL5017 wheelchair projected wh: RAL9016
---	---	---	--	---	--

	CK_.B40 bu: RAL5017 pram wh: RAL9016		CK_.B1 silv: RAL9006 pram bu: RAL5017		CK_.B36 ye: RAL1037 Info bu: RAL5022
---	--	---	---	---	--

	CK_.B50 ye: RAL1023 Handicapped bk: RAL9017		CK_.B33 bu: RAL5017 Handicapped wh: RAL9016		CK_.B30 rd: RAL3020 Bell wh: RAL9016
---	---	---	---	---	--

	CK_.B38 rd: RAL3020 SOS gr: RAL7045		CK_.B54 bk: RAL9017 Light wh: RAL9016		CK_.B57 bk: RAL9017 WC wh: RAL9016
---	---	---	---	---	--

Arrows OPEN + door



Arrows OPEN + Pictogram

Pictograms

Picto-grams

	CK_.B56 rd: RAL3020 SOS wh: RAL9016		CK_.B56.1 bk: RAL9017 SOS rd: RAL3020		CK_.B21 silv: RAL9006 SOS rd: RAL3020
---	--	---	--	--	--

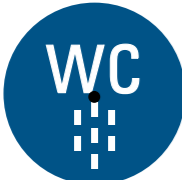
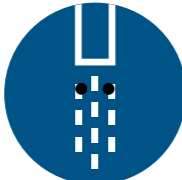
Picto-grams tactile



	CK_.B43 bu: RAL5005 WC 1 dot tactile wh: RAL9016		CK_.B44 bu: RAL5005 Water 2 dots tactile wh: RAL9016		CK_.B45 or: RAL2003 Dryer 3 dots tactile wh: RAL9016
---	--	---	--	--	--

	CK_.B48 bu: RAL5017 coffee cup tactile wh: RAL9016
--	--

Text

	CK_.B32 ye: RAL1023 text bk: RAL9017		CK_.B51 rd: RAL3020 text (braille) wh: RAL9016
--	---	---	---

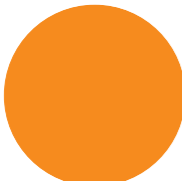
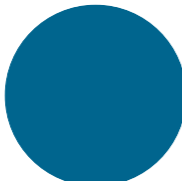
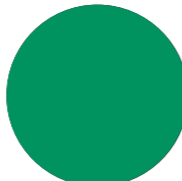
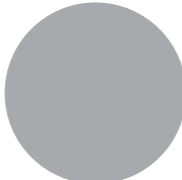
blank

	CK_.F4 or: RAL2011		CK_.B49 bu: RAL5017		CK_.F3 gn: RAL6024
	CK_.F1 silv: RAL9006		CK_.F2 bk: RAL7021		

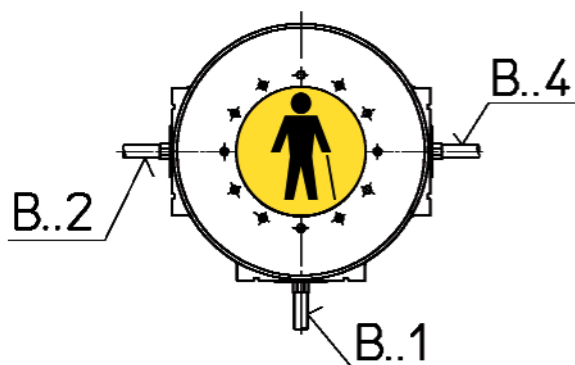

The RAL-colours can only be slightly achieved. Deviations are permissible. The colours shown here are no RAL colours. Please use standard RAL-range for exact colour selection.

Please observe position of cable in relation to pictogram. Order example CK70, Pictogram No. 50., cable on right side: CK70.B50.4.

The illustrated view corresponds to outer side of vehicle. The pictogram on the inner side of vehicle is accordingly mounted mirror-inverted on the vertical axis.

CK Inquiry | So that you will not forget anything, simply mark with a cross and send us a fax or go to internet. Fax +49 2353 66796-99 | www.escha-tsl.de/anfragekompass

Button variants | page 31

CK70 CK71 CK72 CK80 CK81 CK82

Nominal voltage | page 32

24V 110V 24V-110V

LED-Variants | page 32

6gn+6rd other LED-colours: _____

alternating semi-circular individually controlled

Individual? _____

Switching function | page 33

fct.1 fct.2 fct.3 fct.4 fct.5

Acoustic | page 32

Confirm: _____ kHz Intervall: _____ Hz none

Orientation: _____ kHz Intervall: _____ Hz none

others: _____ kHz Intervall: _____ Hz

Mounting variants | page 34-37

Screw mounting with plate Back wall with claws Rubber-ring mounting

Cover housing Glass mounting 2-sided Double-wall mounting

Pictogram.cable outlet | page 38-40

B _____ Special pictogram: _____

Fixingring colours | page 42-43

RAL _____ Special colours: _____

Connector (Standard cable length approx. 160mm) | page 44-45 without plug (2m cable)

Type-No.: _____ Special connector: _____

Special length: _____ Special cable: _____

Your data

Name: _____

Company: _____

Address: _____

Phone: _____

E-mail: _____



Light ivory
similar to RAL1015



Fire red
similar to RAL3000



Traffic green
similar to RAL6024



Traffic grey B
similar to RAL7043

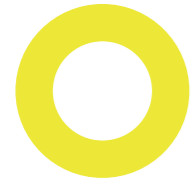

Sulphur yellow
similar to RAL1016



Ruby red
similar to RAL3003



Silver grey
similar to RAL7001

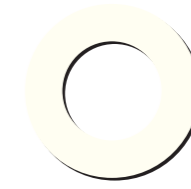

Pure white
similar to RAL9010

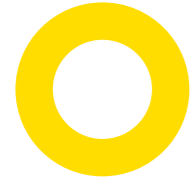

Rape yellow
similar to RAL1021



Traffic red
similar to RAL3020



Granite grey
similar to RAL7026

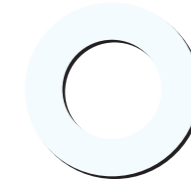

Traffic white
similar to RAL9016

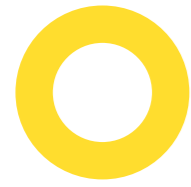

Traffic yellow
similar to RAL1023



Ultra navy blue
similar to RAL5002



Platinum grey
similar to RAL7036

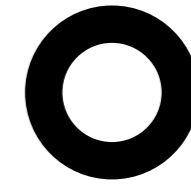

Traffic black
similar to RAL9017



Yellow orange
similar to RAL2000



Traffic blue
similar to RAL5017



Traffic grey A
similar to RAL7042

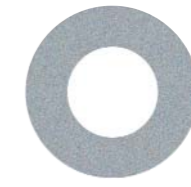

Stainless steel
shot-blasted
with glass balls
(only for CK)



Pastel orange
similar to RAL2003



Capri blue
similar to RAL5019



Other colours
on request



Pure orange
similar to RAL2004



Patina green
similar to RAL6000

The colours illustrated here are no RAL-colours. Please use standard RAL-range for exact colour selection.

The fixing-rings of the buttons MP und PK are plastic moulded parts (POM,PA6GF15), granulate-coloured.



Light red orange
similar to RAL2008



Leaf green
similar to RAL6002

The adapter plates of the MP-range, mounting-plate of PK-range and the fixing rings of the CK-buttons consist of stainless steel, the colouring is effected by powder-coating.

The ESCHA door-opening buttons are available with an open cable head and pre-manufactured cable bushings or a connector.

You can see here three standard cable qualities and the common connectors. Should you not find your specific connection, contact us. We will provide a custom-made solution.



PUR halogen-free A cable for protected wiring, easy and flexible operations inside and outside rail vehicles and busses.
 Type-code: Li9Y11YFHFV
 Jacket colour: black
 Wire material: PP
 Conductor material: EL-Cu, verzinkt
 Flame protection: UL 1587 § 1061

PUR halogen-free irradiated A cable for protected wiring, permanently flexible operations inside and outside rail vehicles and busses.
 Type-code: D12YSL11X
 Jacket colour: orange
 Wire material: PE
 Conductor material: EL-Cu, tinned

RADOX® GKW S A cable for protected wiring inside and outside rail vehicles and busses.
 Type-code: Tenius-TW/S
 Jacket colour: black
 Wire material: GKW TP/GKW TS
 Conductor material: EL-Cu, tinned
 Flame protection: DIN5510-2, NFF16-101, BS 6853

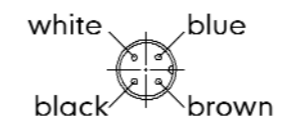

plug-No.	description	Pole	Brand Item-No./Typecode
0	Round connector Ø2 mm	4	TYCO Electronics/AMP Item-No.: 0-925 075-0

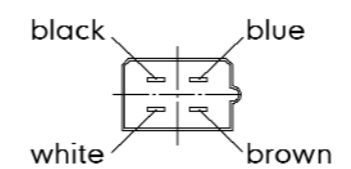

1	Flat connector FASTIN-FASTON 6.3x0.8	4	TYCO Electronics/AMP Item-No.: 180901-0
---	--------------------------------------	---	---

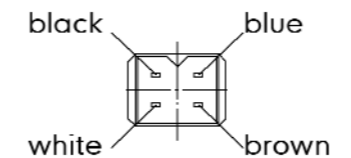

2	Flat connector FASTIN-FASTON 2.8x0.8	4	TYCO Electronics/AMP Item-No. 626 057-0
---	--------------------------------------	---	---

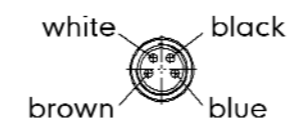

60	Round connector Snap-in + M8x1 screwed	3-4	ESCHA Bauelemente 3- and 4-poles SSP3 SSP4 according to BN65074
----	--	-----	---

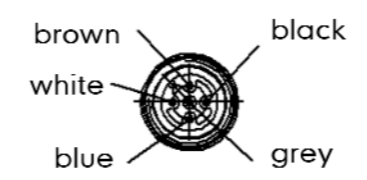

61	Round connector M12x1 screwed	4-8	ESCHA Bauelemente 4-, 5-, 6- and 8-poles WAS4...WAS8 according to BN65074
----	-------------------------------	-----	---

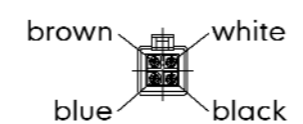

64	Rectangular connector MATE-N-LOK	4	TYCO Electronics/AMP Item-No. 794805-1
----	----------------------------------	---	--

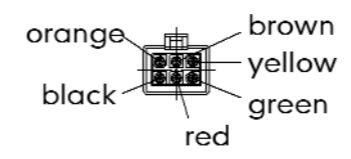

65	Rectangular connector MATE-N-LOK	6	TYCO Electronics/AMP Item-No. 794895-1
----	----------------------------------	---	--

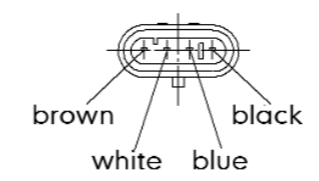

66	SUPERSEAL-Connector	4	TYCO Electronics/AMP Item-No. 282106-1
----	---------------------	---	--

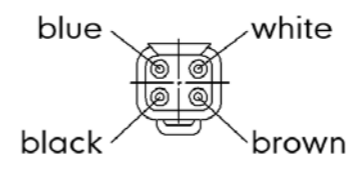

71	Rectangular connector	4	DEUTSCH DTM04-4P
----	-----------------------	---	------------------

- Polycarbonate PC, UV stabilized** is a thermoplast, which combines many advantageous properties, such as rigidity, impact strength, transparency, form and dimensional stability, good insulating properties and thermal stability. Polycarbonate is used in door-opening buttons for the one-part, hermetically sealed switch housings of the MP and PK product range. Polycarbonate is highly resistant to mineral acids, saturated aliphatic carbons, gasoline, greases and oils. The material is not especially resistant to solvents, naphtha, caustic solutions, acetone and ammonia.
- Polyamide PA, glass fiber reinforced GF** Glass fiber reinforced polyamides are characterized by high rigidity and hardness and higher operating temperatures as compared with non-reinforced materials. This thermoplast displays excellent mechanical stability even at high ambient temperatures. It absorbs water from the environment (ca. 2.8%) and stores it as a chemically bonded H₂O group in the molecular structure. This makes the material elastic and unbreakable, even at temperatures down to -40°C. Polyamide, glass fiber reinforced is used in door-opening buttons, e.g. as a PK fixing-ring.
- Polyoxymethylene POM** is a semi-crystalline thermoplastic polymer and is used wherever high rigidity and high mechanical strength are required in combination with springiness and/or good sliding friction behavior. The material is resistant to water, alcohols, aliphatic and aromatic carbons, caustic solutions, fuels, greases, oils, brake fluids and coolants. We use polyoxymethylene in fastening rings for the MP-range.
- Nitrile butadiene rubber NBR** is an elastomer used as a sealing element to achieve the required IP protection degrees in ESCHA door-opening buttons. Rubber manufactured from NBR is resistant to many chemicals, mineral oils and greases and displays low abrasive behavior, high resistance to aging and has a large operating temperature range from -40°C to +125°C. NBR is not weather-resistant and not resistant to high-flash-point hydraulic fluids and synthetic lubricants.
- Ethylene propylene terpolymer EPDM** is used for sealing elements with a weight by volume of more than 10g. It can be used at temperatures from -40°C to +120°C and is generally very resistant to weather and water. The requirements for behavior in fire in accordance with the standard railway norms are fulfilled.

- Polyurethane PUR, halogen-free** is a cable material, which was specially developed for permanently flexible control lines and for use under extreme conditions. PUR is especially useful due to its high abrasion resistance. The material is very resistant to oils, lubricants and coolants, as well as other aggressive media. The thermal endurance is +90°C.
- Polyurethane, irradiated.** The typical properties of PUR are significantly improved by electron irradiation crosslinking of the PUR material. This increases not only the mechanical stability and resistance to chemicals, but also abrasion and temperature resistance. PUR irradiated is suitable for thermal endurance of +105°C.
- RADOX® GKW S RADOX®** insulating and encasing materials are primarily electron irradiated materials with special properties: high temperature resistance, excellent behavior in fire, reduced wall thicknesses and good working properties.
- Stainless steel V2A** for rugged operating conditions on roads and rail vehicles we use powder-coated stainless steels for screws, fixingrings or adapterplates. This makes the door-opening buttons resistant to vandalism and to cleaning agents and graffiti removers. The powder coating enables us to design surfaces in any desired color.

IEC 60529 | Protection classes for electrical equipment

Electrical equipment has to be protected for safety reasons against external influences, such as dust, foreign objects, contact, humidity and water. This protection is provided by means of housings. IEC60529 is the basis for the definition and labeling of the protection class of a housing. The extent of the protection is demonstrated by standardized test methods.

The protection degrees are indicated by a code consisting of the two letters IP (International Protection) and a two-digit number for the degree of protection.

The first digit indicates the degree of protection against contact and foreign objects.

The second digit indicates the degree of protection against the damaging penetration of water.

The protection degrees have the following form:

IP67 International Protection Digit 1 Digit 2

Digit 1

0	Not protected	
1	Protected against access to dangerous elements with the back of the hand. Protected against solid foreign objects with a diameter of Ø 50mm.	
2	Protected against access to dangerous elements with the fingers. Protected against solid foreign objects with a diameter of Ø 12,5 mm.	
3	Protected against access to dangerous elements with a tool. Protected against solid foreign objects with a diameter of Ø 2,5mm.	
4	Protected against access to dangerous elements with a wire. Protected against solid foreign objects with a diameter of Ø 1 mm.	
5	Protected against access to dangerous elements with a wire. Dust-protected.	Penetration by dust is not fully prevented, but the dust cannot penetrate in such a quantity so as to hinder satisfactory operation of the equipment or safety.
6	Protected against access to dangerous elements with a wire. Dust-proof.	No penetration by dust.

Digit 2

0	Not protected	
1	Protected against dripping water	
2	Protected against dripping water when the housing is tilted up to 15°	
3	Protected against spraying water	Water, sprayed at an angle of up to 60° on both sides of the perpendicular; must have no damaging effect.
4	Protected against splashing water	Water sprayed from any direction against the housing may have no damaging effects.
5	Protected against water jet	Penetration by dust is not fully prevented, but the dust cannot penetrate in such a quantity so as to hinder satisfactory operation of the equipment or safety.
6	Protected against strong water jet	No penetration by dust.
7	Protected against the effects of temporary immersion in water	Water may not penetrate in a quantity that causes damaging effects if the housing is immersed in water for 30 minutes at a depth of 1 meter.
8	Protected against the effects of prolonged immersion in water	Water may not penetrate in a quantity that causes damaging effects if the housing is immersed in water permanently under conditions that have to be agreed upon by the manufacturer and the user. However, the conditions must be more difficult than for code number 7.
9K	Protected against water under high pressure, steam jet cleaning	

IEC 61373 – Rail applications | Equipment of railway vehicles – Tests for vibrations and shocks.

This international standard defines the requirements for the tests of equipment intended for use on railway vehicles that are subjected to vibrations and shocks that are normal for railway operation. To ensure that the quality of the equipment is acceptable, it has to endure tests of a reasonable duration that simulate the operating conditions during the expected service life.

Number 8/9	Vibrations, wide band vibrations
Number 10	Shocks, half-sine

EN 50155 – Railway applications | Electronic devices on railway vehicles.

Electronic components on railway vehicles are subjected to many external influences, such as temperature deviations, vibrations, shocks and strong electric fields. The standard specifies the requirements for measuring, control, regulation and safety of devices under these conditions. It covers operating conditions, dimensioning, design and testing of the electronic devices, in addition to the basic hardware and software requirements deemed necessary for an effective, reliable device.

Number 12.2.3	Cold test Ad
Number 12.2.4.	Dry heat test Bd
Number 12.2.5.	Wet heat, cyclical Db55
Number 12.2.9.1	Insulation test
Number 12.2.9.2	Dielectric strength test
Number 12.2.10	Salt spray test Ka (Class ST3)
Number 12.2.11	Vibrations, shock and jolt tests

DIN 5510-2 – Preventive fire protection in rail vehicles | Fire behavior and fire side effects of materials and components. This standard defines the requirements for fire behavior and fire side effects (smoke and drop forming capacity) deemed necessary for the materials and components used for the construction of rail vehicles.

DIN 32974 – Acoustic signals in public traffic areas This standard assigns a functional meaning to acoustic signals – as far as possible – with signal classes that suggest appropriate action based on the signal properties (characterized, for example, by the audio frequency, clock frequency, sound pressure level, pulse frequency, signal duration, etc.); i.e. the acoustic signal should inherently indicate whether the signal is a warning, notification, release, orientation or confirmation signal.

DIN EN 50306-1 – Cables and wires for rail vehicles with improved behavior in fire The purpose of this standard is to standardize cables and wires that are safe and reliable when used correctly; to define the properties, performance and design requirements that contribute to safety directly or indirectly; and to define test procedures for compliance with these test methods

DIN EN 13272 – Electric lighting in rail vehicles used in public transportation This European standard defines the criteria for the design of electric lighting systems that apply for the interiors of rail vehicles used in public transportation under all operating conditions. The lighting must enable performance of all tasks connected with sight.

IEC 60077-1 – Railway applications – Electrical equipment on rail vehicles
Part 1: General operating conditions and general rules
Number 9.3.3.1. High-voltage test

Directive 2006/28/EG – Electromagnetic compatibility of motor-driven vehicles and their electric and electronic components EMC is an important quality characteristic of any product. Electromagnetic compatibility (EMC) of a device, system or plant refers to limiting the emission of electromagnetic interference to a degree that ensures trouble-free operation of other devices in the vicinity and also ensuring sufficient resistance to external electromagnetic interference, so that the device can be operated as intended at the planned location under the electromagnetic interference conditions to be expected there.

DIN EN 50121-3-2 – Electromagnetic compatibility – Part 3.2: Rail vehicles – Devices
This European standard defines EMC (electromagnetic compatibility) requirements for interference emissions and resistance of electric and electronic devices intended for use in rail vehicles.

DIN 75077 Motorbuses for physically-handicapped persons The purpose of this standard is to define minimum requirements for motorbuses beyond the applicable traffic regulations in order to enable the safe and comfortable transport of mobility-handicapped persons.

BN 65074 Buttons for entry doors This railway standard attempts to standardize the interface between man and machine at the passenger doors. It describes the technical requirements for a standardized door-opening button. The standard applies to entry doors in passenger trains and multiple-unit trains.

EN 14752 Railway applications – Side entry systems This standard describes the requirements for request buttons and door buttons (external and internal) for the blind and visually-impaired. The buttons must be tactile with high contrast.

Directive 2001/85/EG – Special regulations for vehicles for personal transportation with more than eight seats This directive describes special requirements for the operation and design of communication devices at handicapped seats.

Contact



Head office

ESCHA TSL GmbH
Elberfelder Str. 1
D-58553 Halver
Phone: +49 2353 66796-0
Fax: +49 2353 66796-99
www.escha-tsl.de
info@escha-tsl.de

Branch office

ESCHA TSL GmbH
Gerhard Freinik
D-65529 Waldems | Langgasse 3 a
Phone: +49 6082 929056
Fax: +49 6082 929057
Mobil: +49 175 2240098
g.freinik@escha-tsl.de

Representations

Belgium

Multiprox N. V.
Lion d'Orweg 12
B-9300 Aalst
Phone: +32 53 766566
Fax: +32 53 783977
mail@multiprox.be

China

Turck(Tianjin)Sensor Co.Ltd.
No. 18 Xinghuasizhi Road Xiqing
TEDA Tianjin 30081
VR China TJ-300385 Tianjin
Phone +86 22 83988188
Fax: +86 22 83988111
turck@public1.tpt.tj.cn

Denmark

Hans Følsgaard A/S
Theilsgaards Torv 1
DK-4600 Køge
Phone: +45 43 208600
Fax: +45 43 968855
hf@hf.net

Great Britain

TURCK Banner Ltd.
Blenheim House
Hurricane Way
GB-Wickford, Essex SS11 8YT
Phone: +44 1268 578888
Fax: +44 1268 763648
info@turckbanner.co.uk

India

TURCK India Automation Pvt. Ltd.
International Convention Centre
A-603/604, 6th Floor
ICC Trade Towers
Senapati Bapat Road
Pune - 411016
Maharashtra - India
Phone: +91 9820173367
Fax: +91 2025630039
anuj.nijhawan@turck.com

Italy

Turck Banner S.r.l.
Via San Domenico 5
I-20010 Bareggio (MI)
Phone: +39 02 90364291
Fax: +39 02 90364838
info@turckbanner.it

Canada

Hirotronix Inc.
687 Sir Richard's Rd
CAN-Mississauga ON L5C 1A3
Phone: +1 905 272 0075
Fax: +1 905 270 7955
sales@hirotronix.com

South Korea

Turck Korea Co, Ltd.
Room No. 406, Gyeonggi Technopark
1271-11, Sa 1-Dong, Sangnok-Gu, Ansan
ROK426-901 Gyeonggi-Do
Phone: +82 31 5004555
Fax: +82 31 5004558
sensor@sensor.co.kr

Netherlands

Turck B.V.
Postbus 297
Ruiterlaan 7
NL-8000 AG Zwolle
Phone: +31 38 4227750
Fax: +31 38 4227451
info@turck.nl

Norway

HF DANYKO AS
Postboks 48
N-4891 Grimstad
Phone: +47 37090940
Fax: +47 37090941
danyko@hf.net

Austria

MBM Industrietechnik
Vertriebsges.m.H.
Leopold Mitterstöger-Str. 38
A-3012 Wolfgraben
Phone: +43 2233 7282
Fax: +43 2233 728212
office@mbm-industrietechnik.at

Poland

Turck sp.zo.o
Zeromskiego 1
PL-45053 Opole
Phone: +48 77 4434800
Fax: +48 77 4434801
turck@turck.pl

Portugal

Salmon&Cia.Lda.
Rua Cova da Moura 2-6°
P-1399-033 Lisboa
Phone: +351 21 3920130
Fax: +351 21 3920189
salmon@salmon.pt

Turkey

Gökhan Elektrik
Malzemeleri Sanayi ve Ticaret LTD STI.
Perpa Elektrokent is Merkezi A Blok
K.8 No.692-694
TR-80270 Okmeydani-Istanbul
Phone: +90 212221 3236
Fax: +90 212221 3240
gokhan@gokhanelektrik.com

Russian Federation

Turck Rus OOO
Altufyevskoe shosse, 1/7
RUS-127106 Moscow
Phone: +7 495 2342661
Fax: +7 495 2342665
russia@turck.com

Sweden

HF SVERIGE AB
Kanalvägen 10c
S-19461 Upplands Väsby
Phone: +46 8 55540985
Fax: +46 8 55540987
hf.sverige@hf.net

Switzerland

Dietrich&Blum AG
Hertistrasse 31
CH-8304 Wallisellen
Phone: +41 848 300700
Fax: +41 848 300701
dbnet@dietrichundblum.ch

Slovakia

MARPEX S.R.O.
Sportovcov 672
SK-01841 Dubnica Nad Váhom
Phone: +421 42 4426986
Fax: +421 42 4426987
marpex@marpex.sk

Spain

Comercial Key, S.L.
Padilla, 216 Entl. 1
E-08013 Barcelona
Phone: +34 93 2464545
Fax: +34 93 2465509
key@comercialkey.com

Czech Republic

Turck S.R.O.
Hradecká 1151
CZ-50002 Hradec Králové
Phone: +420 49 5518766
Fax: +420 49 5518767
turck@turck.cz

Romania

TURCK Automation Romania SRL
Str. Iuliu Tetrat nr. 18, sector 1
RO-011914 Bucuresti
Phone: +40 21 2314087
Fax: +40 21 2314087
info@turck.ro

Hungary

Turck Hungary Kft.
Könyves Kalman Krt. 76
H-1087 Budapest
Phone: +36 1 4770740
Fax: +36 1 4770741
turck@turck.hu