



- New fault annunciation according to DIN 19235
- Expandable from 3 up to 303 inputs
- Width 45 mm

### Fault annunciator AD 5998:

- 3 inputs
- Pushbutton connection possible for light signal acknowledgement, horn acknowledgement and lamp test
- 1 relay for common alarm and 1 for horn

### Extension unit AD 5992:

- 6 inputs

### Function Diagram

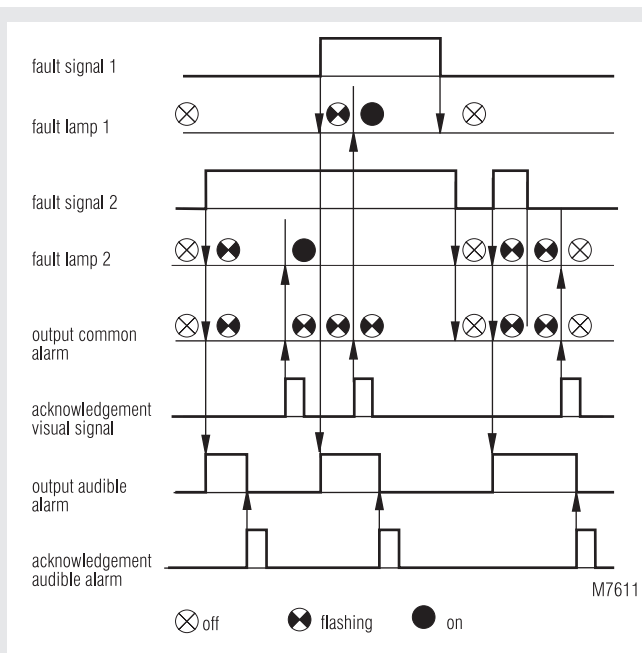

### Approvals and Marking



### Application

Monitoring of industrial plants and buildings

### Notes

The connections A1, inputs S1-S3 and S1-S6, lamp test input LT and acknowledgement input Q have to be connected to the same phase.

Even if no common signal light will be connected, the nominal voltage is to be connected to terminal 27.

The bus-lines H and S have a low voltage and are not allowed to be connected to any external voltage. If inductive or capacitive superimposed voltages are expected, it is recommended to use screened cables for these lines.

The flash impulse via flash line BS will be generated by an internal contact. The maximum load of this contact must be observed (technical data).

It is not allowed to connect lamps with transformers on the outputs. This would cause unintentional fault signals at the lamp test.

### Circuit Diagrams

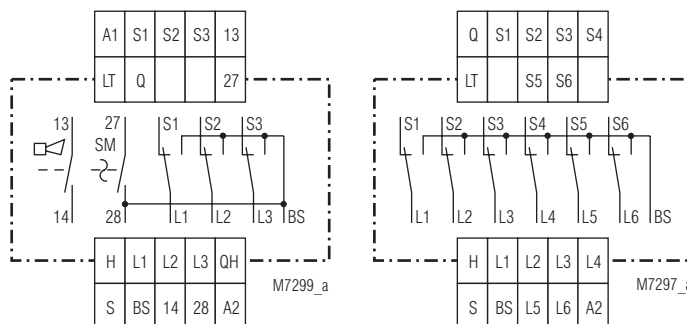

AD 5998

AD 5992

In case of units with AC-voltage, the signal lights during the lamp test are lighting dim, as the test will be effected only with a half-wave. The half-wave voltage is also applied at terminals S1-S3 and S1-S6 during the lamp test.

If other lamps, except for the fault signal lamps, should be tested via the lamp test pushbutton T1, it is necessary to use a lamp tester, whose diode configuration is identically to the diode configuration of the fault annunciator. In case of AC-voltage operation this is the lamp tester AI 990/04, in case of DC-voltage operation the lamp tester AI 990 or AI 990.10.

## Technical Data

### Input

**Nominal voltage  $U_N$ :** AC 24, 230, 240 V,  
DC 24 V with polarity protection  
AC 42, 110, 127 V on demand

**Special voltages:** with additional resistors  
(see connection example)

	AD 5998		AD 5992
	RV	R1	R2
DC 48 V:	ZWS 8 sl 390 $\Omega$	ZWS 8 sl 2.7 k $\Omega$	ZWS 8 sl 430 $\Omega$
DC 60 V:	ZWS 8 sl 640 $\Omega$	ZWS 20 sl 4.7 k $\Omega$	ZWS 8 sl 640 $\Omega$
DC 110 V:	ZWS 20 sl 1.5 k $\Omega$	ZWS 20 sl 10 k $\Omega$	ZWS 20 sl 1.5 k $\Omega$
DC 125 V:	ZWS 20 sl 1.8 k $\Omega$	ZWS 20 sl 12 k $\Omega$	ZWS 20 sl 1.8 k $\Omega$
DC 230 V:	ZWS 20 sl 3.3 k $\Omega$	ZWS 20 sl 24 k $\Omega$	ZWS 20 sl 3.3 k $\Omega$

**Voltage range:** 0.8 ... 1.1  $U_N$

**Nominal consumption:** AC 230 V 6 VA DC 24 V 1.5 W

**Nominal frequency:** 50 / 60 Hz

**Fault impulse time:**  $\geq$  100 ms

**Acknowledgement impulse time:**  $>$  200 ms

### Output

#### Loading:

AD 5992 / AD 5998  
signal light each:  
(terminals L1, L2, L3, L4,  
L5, L6 bzw. L1, L2, L3)

AC 230 V 1 A max.

AD 5998  
Audible-alarm output  
(terminal 14): AC 230 V 3 A max.

Common alarm output  
(terminal 28) and lamp signal  
via flash line BS totally: AC 230 V 3 A max.  
DC 24 V 2 A max.  
for higher switching capacity  
a contactor is to be inserted

Lamp test (pushbutton 1): Sum of the currents of all lamp signals L

### General Data

**Operation mode:** Continuous operation

**Temperature range:** - 20 ... + 60°C

**Clearance and creepage distances**

rated impuls voltage /  
pollution degree: 4 kV / 2 IEC 60 664-1

**EMC**

Electrostatic discharge: 6 kV (contact) IEC/EN 61 000-4-2

HF-irradiation: 10 V / m IEC/EN 61 000-4-3

Fast transients: 2 kV IEC/EN 61 000-4-4

Surge voltages: 1 kV IEC/EN 61 000-4-5

Interference suppression: Limit value class B EN 55 011

**Degree of protection:** Housing: IP 40 IEC/EN 60 529  
Terminals: IP 20 IEC/EN 60 529

**Housing:** Thermoplast with V0 behaviour  
according to UL subject 94

**Vibration resistance:** Amplitude 0.35 mm,  
frequency 10...55Hz IEC/EN 60 068-2-6  
20 / 060 / 04 IEC/EN 60 068-1

**Climate resistance:**

**Terminal designation:** EN 50 005

**Wire connection:** 2 x 2.5 mm<sup>2</sup> solid or  
2 x 1.5 mm<sup>2</sup> stranded wire with sleeve  
DIN 46 228

**Wire fixing:** Flat terminals with self lifting  
clamping piede IEC/EN 60 999-1  
DIN rail IEC/EN 60 715

**Mounting:**

**Weight**

AD 5998: AC 230 V 380 g DC 24 V 250 g

AD 5992: 360 g 220 g

### Dimensions

**Width x height x depth:** 45 x 77 x 127 mm

## Standard Types

AD 5998 AC 230 V 50/60 Hz  
Article number: 0032367 stock item

- Nominal voltage  $U_N$ : AC 230 V
- Width: 45 mm

AD 5992 AC 230 V 50/60 Hz  
Article number: 0032361 stock item

- Nominal voltage  $U_N$ : AC 230 V
- Width: 45 mm

## Ordering Example

AD 5998 AC 230 V 50/60 Hz

Nominal frequency  
Nominal voltage  
Type

## Connection Examples

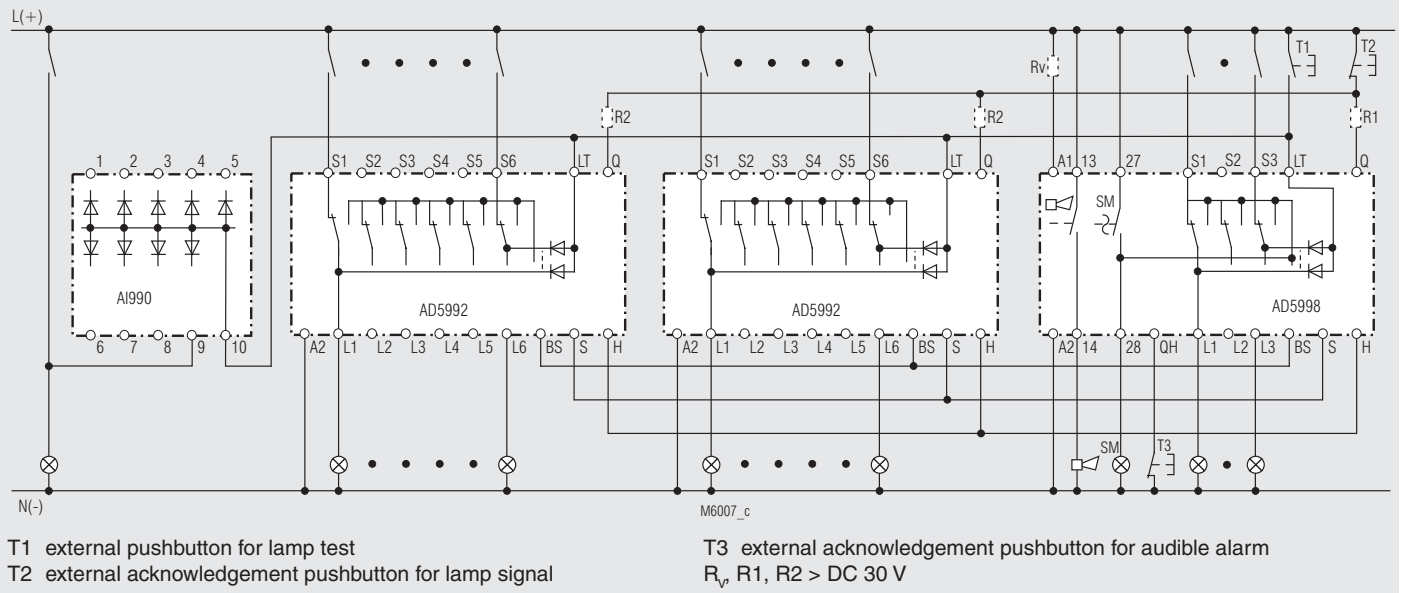

Connection diagram AD 5998 - AD 5992 for operation at DC-voltage with additional lamp tester AI 990 or AI 990.10  
Lamp tester AI 990 is only required if additional lamps in the system need to be tested.

## Connection Examples

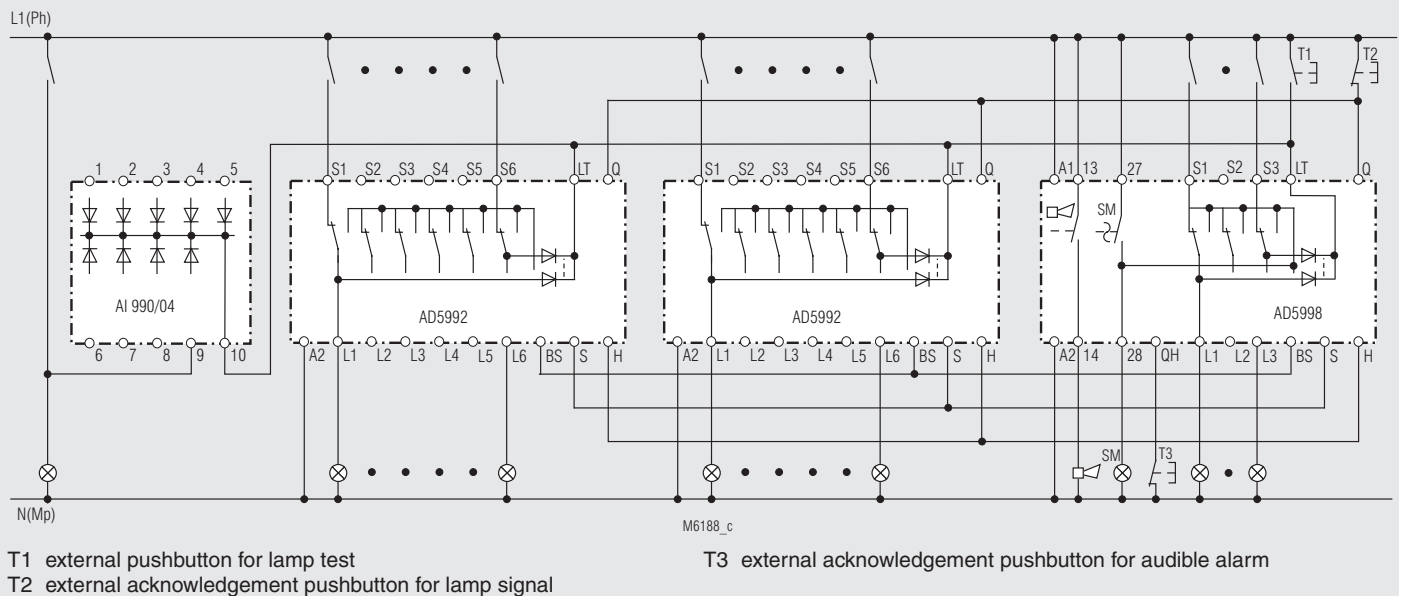

Connection diagram AD 5998 - AD 5992 for operation at AC-voltage with additional lamp tester AI 990.04 or AI 990.12  
Lamp tester AI 990 is only required if additional lamps in the system need to be tested.

