

- According to IEC/EN 61 810-1
- Relay, triac or transistor output
- Protective separation according to IEC/EN 61 140, IEC/EN 60 947-1 on devices with relay output (only at  
IK 3070.01 / \_0\_,  
IK 3070.02 / \_0\_,  
IK 3070.11 / \_0\_)
- LED as operating position display
- Optionally input wiring with recovery diode or MOV
- Optionally for small switching currents
- Optionally with forcibly guided contacts
- As option with 3-position test switch:  
Auto, Off, Manual/Sensor control (+ 24 V)
- As option with semiconductor output  
- for high switching frequency  
- input protection with varistor
- Optionally interface relay system to reduce the amount of wiring
- IK 3070: width 17.5 mm  
IS 3070: width 140 mm

### Circuit Diagrams

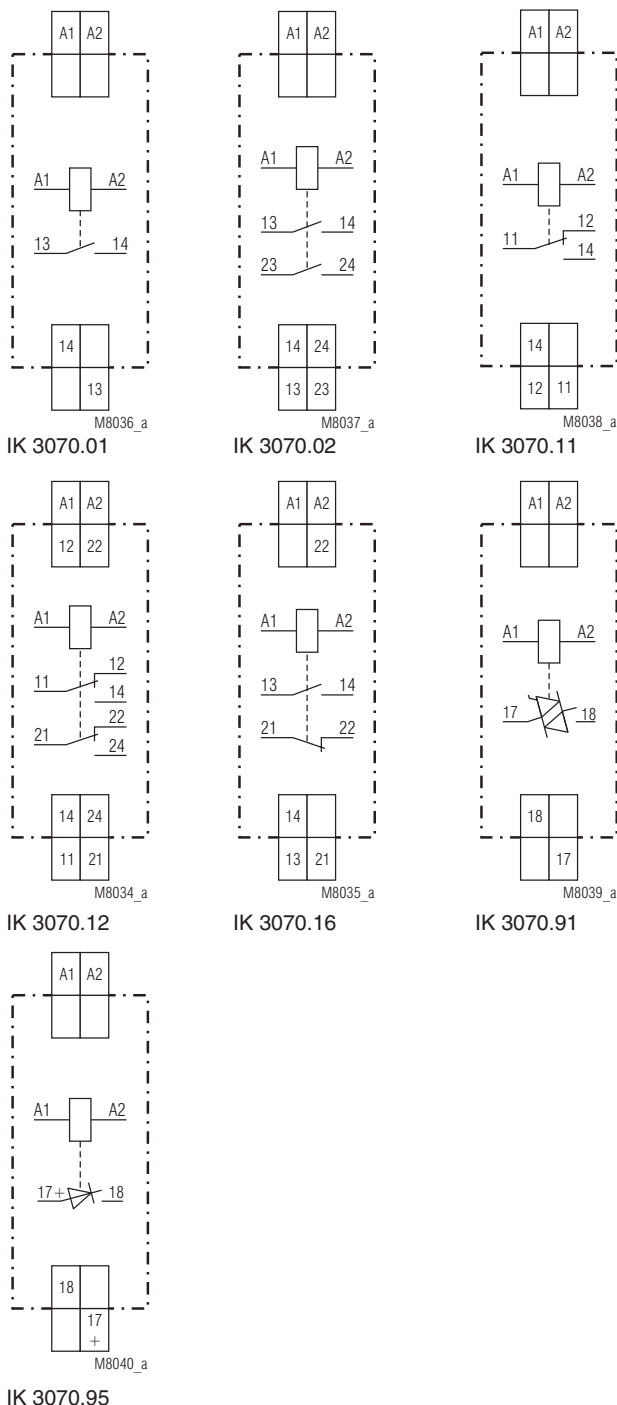

### Approvals and Marking



### Applications

- Link between the control and the power level
- For separating potentials

### Indicators

green LED: on, when supply connected

### Technical Data

#### Input for Interface Relay with Relay Output

**Nominal voltage  $U_N$ :** DC 24 V  
AC 230 V  
Other nominal voltages available on request

**Voltage range:** DC 0.9 ... 1.2  $U_N$   
AC 0.8 ... 1.1  $U_N$

**Nominal consumption:** DC approx. 0.5 W  
AC approx. 0.9 W

#### Input for Interface Relay with Semiconductor Output

**Nominal voltage  $U_N$ :** DC 24 V AC 230V

**Voltage range:** DC 18 ... 30 V AC 0.8 ... 1.1  $U_N$

**Input current:** approx. 10 mA approx. 10 mA

**Power consumption:** approx. 0.25 W approx. 2.5 VA

**Nominal frequency:** - 50 / 60 Hz

**Frequency range:** -  $\pm 5\%$

**Protection:** Varistor Varistor

### Relay Output

**Contacts**

IK 3070.01: 1 NO contact

IK 3070.02: 2 NO contacts

IK 3070.11: 1 changeover contact

IK 3070.12: 2 changeover contacts

IK 3070.16: 1 NO, 1 NC contact

**Reaction time:**  $\leq 10$  ms

**Release time:**  $\leq 15$  ms

**Nominal switching voltage:** AC 250 V

**Nominal output voltage:** min. AC 8 V; max. AC 400 V

**Switching-on capacity:** min. 0.3 A  
max. 8 A or  
2 x 5 A at the same time

Technical Data		
<b>Thermal current <math>I_{th}</math>:</b>	max. 8 A (see continuous current limit curve)	
IK 3070.12, IK 3070.16:	2 x 5 A	
<b>Switching capacity</b> for IK 3070.01; IK 3070.11:		
to AC 15:	6 A / AC 230 V	IEC/EN 60 947-5-1
to DC 13:	2 A / DC 24 V	IEC/EN 60 947-5-1
for IK 3070.02		
to AC 15:	3 A / AC 230V	IEC/EN 60 947-5-1
to DC 13:	2 A / DC 24V	IEC/EN 60 947-5-1
for IK 3070.12; IK 3070.16:		
to AC 15		
NO contact:	3 A / AC 230 V	IEC/EN 60 947-5-1
NC contact:	1 A / AC 230 V	IEC/EN 60 947-5-1
to DC 13		
NO contact:	1 A / DC 24 V	IEC/EN 60 947-5-1
NC contact:	1 A / DC 24 V	IEC/EN 60 947-5-1
<b>Electrical life</b> to AC 15 at 3 A, AC 230 V:	≥ 2.5 x 10 <sup>5</sup> switching cycles	
<b>Permissible switching frequency:</b>	max. 10 switching cycles / s	
<b>Short circuit strength</b> <b>max. fuse rating:</b>	10 A gL	IEC/EN 60 947-5-1
IK 3070.12, IK 3070.16:	4 A gL	IEC/EN 60 947-5-1
<b>Mechanical life:</b>	≥ 50 x 10 <sup>6</sup>	

#### Transistor Output for DC-Load (pay attention to polarity)

IK 3070.95:	1 Transistor
<b>Nominal output voltage:</b>	DC 24 V
<b>Voltage range:</b>	DC 0 ... 30 V
<b>Switching current:</b>	max 5 A (see diagram)
<b>Pick-up time:</b>	< 2 ms
<b>Drop-out time:</b>	< 18 ms
<b>Max. overcurrent:</b>	25 A, max. 5 s (not cyclic)
<b>Residual voltage:</b>	< 0.3 V
<b>Residual current:</b>	< 1 mA
<b>Min. load current:</b>	1 mA
<b>Protection:</b>	Varistor (tp = 2 ms 8.6 J)

#### Triac Output for AC-Load

IK 3070.91:	1 Triac
<b>Nominal output voltage:</b>	AC 230 V
<b>Voltage range:</b>	AC 12 ... 275 V
<b>Switching current:</b>	max. 3 A (see diagram)
<b>Pick-up time:</b>	< 12 ms
<b>Drop-out time:</b>	< 20 ms
<b>Max. overcurrent:</b>	25 A, max. 5 s (not cyclic)
<b>Residual voltage:</b>	< 1.1 V
<b>Residual current:</b>	< 1 mA
<b>Min. load current:</b>	50 mA
<b>Protection:</b>	Varistor (tp = 2 ms 8.6 J)

#### General Data

<b>Operating mode:</b>	Continuous operation	
<b>Temperature range:</b>	- 20 ... + 55 °C	
<b>Clearance and creepage distances</b> rated impuls voltage / pollution degree:	4 kV / 2	IEC 60 664-1
<b>Rated surge voltage:</b>	5 kV with MOV	DIN VDE 0435-303
Variants with relay output:	1 kV without MOV	
Variants with semiconductor outputs:	1 kV without MOV	
<b>EMC</b> Electrostatic discharge:	8 kV (air)	IEC/EN 61 000-4-2
HF irradiation		
Variants with relay output:	10 V / m	IEC/EN 61 000-4-3
Variants with semiconductor outputs:	3 V / m	IEC/EN 61 000-4-3
Fast transients:	4 kV	IEC/EN 61 000-4-3
Surge voltages between		
wires for power supply:	2 kV	IEC/EN 61 000-4-5
between wire and ground:	4 kV	IEC/EN 61 000-4-5
HF-wire guided:	10 V	IEC/EN 61 000-4-6
Interference suppression:	Limit value class B	EN 55 011

Technical Data		
<b>Degree of protection</b> Housing:	IP 40	IEC/EN 60 529
Terminals:	IP 20	IEC/EN 60 529
<b>Housing:</b>	Thermoplastic with V0 behaviour according to UL subject 94	
<b>Vibration resistance:</b>	Amplitude 0.35 mm IEC/EN 60 068-2-6 frequency 10 ... 55 Hz	
<b>Climate resistance:</b>	Humid heat IEC/EN 60 068-2-30	
<b>Terminal designation:</b>	EN 50 005	
<b>Wire connection:</b>	2 x 2.5 mm <sup>2</sup> solid or 2 x 1.5 mm <sup>2</sup> stranded ferruled DIN 46 228-1/-2/-3/-4	
<b>Wire fixing:</b>	Flat terminals with self-lifting clamping piece IEC/EN 60 999-1 DIN rail IEC/EN 60 715	
<b>Mounting:</b>		
<b>Weight</b> IK 3070:	68 g	
IS 3070:	520 g	
<b>Dimensions</b>		
<b>Width x height x depth:</b> IK 3070:	17.5 x 90 x 58 mm	
IS 3070:	140 x 90 x 58 mm	

Standard Type		
IK 3070.02/002 DC 24 V		
Article number:	0045093	stock item
• Output:2 NO contacts		
• Nominal voltage $U_N$ :DC 24 V		
• With operating position display (LED)		
• Width: 17.5 mm		

Variants*	
IK 3070. ... /	
Input circuit	
0 Standard	
1 with MOV	
2 with LED as operating position display	
8 with recovery diode for DC version	
A with MOV and recovery diode DC version	
B with MOV and LED as operating position display	
C with LED as operating position display and recovery diode DC version	
D with MOV, LED as operating position display and recovery diode DC version	
Additional functions	
0 Standard	
1 forcibly guided contacts at IK 3070.02, IK 3070.12, IK 3070.16	
2 with test switch at IK 3070.01, IK 3070.11	
Contacts	
0 Standard	
1 for small loads (0.3 ... 60 V, 1 ... 300 mA)	
01 1 NO contact	
02 2 NO contacts	
11 1 changeover contact	
12 2 changeover contacts (only variants with MOV possible)	
16 1 NO, 1 NC contact (only variants with MOV possible)	
91 1 NO contact semiconductor triac only with /001 or /00B	
92 1 NO contact semiconductor transistor only with /001 or /00B	

\* on request

#### Ordering example for variants

IK 3070	.12	/ _ _ _	DC 24 V	
				Nominal voltage
				Variant, if required
				Contact
				Type

## Characteristics

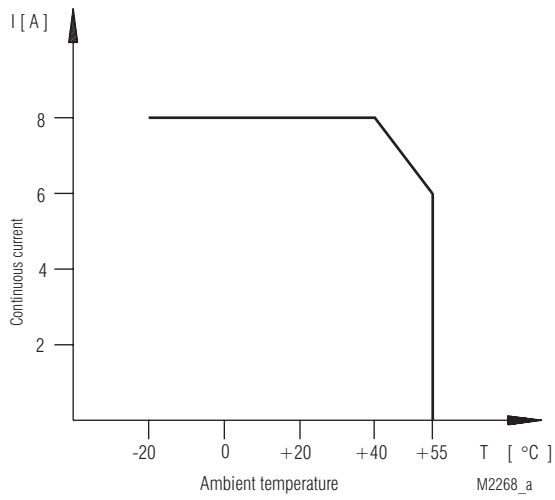

Continuous current limit curve for IK 3070.01, IK 3070.02, IK 3070.11

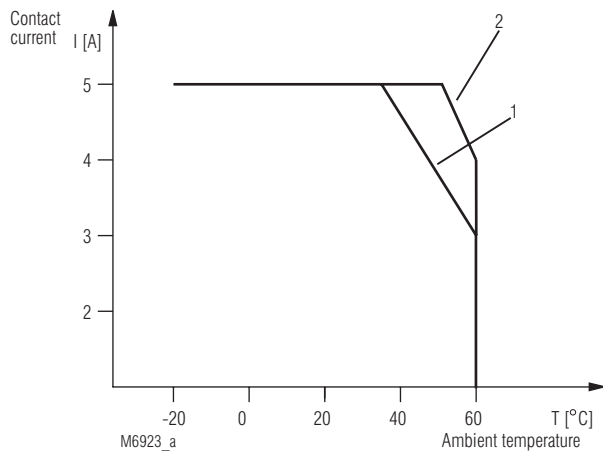

Continuous current limit curve for IK 3070.12, IK 3070.16

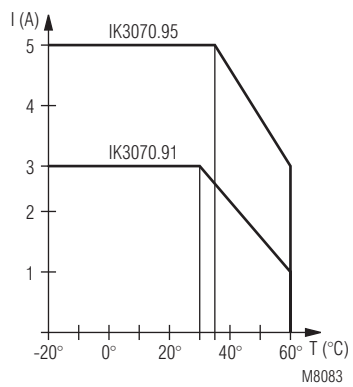

Continuous current limit curve for IK 3070.95, IK 3070.91

Interface Relay System I\_ 3070  
 Input-Output Interface Relay / imod - omod

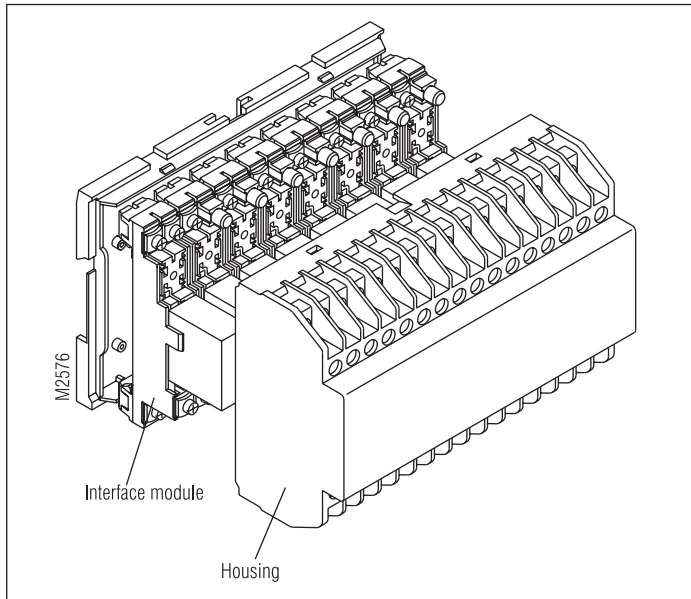

The interface relay system consists of a maximum of 8 interface modules that are accommodated in a housing. The product configuration can be chosen as required according to the different versions shown here. The purpose of the enquiry form below is to specify the required interface relay system.

**Applications**

To reduce the amount of wiring required for several interface relays.

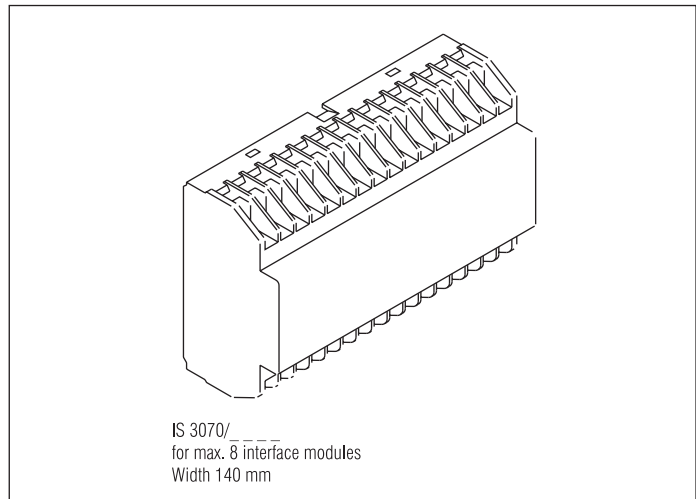
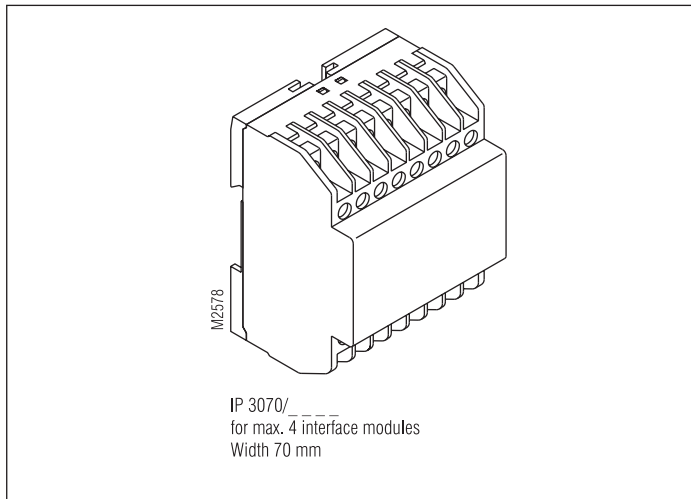
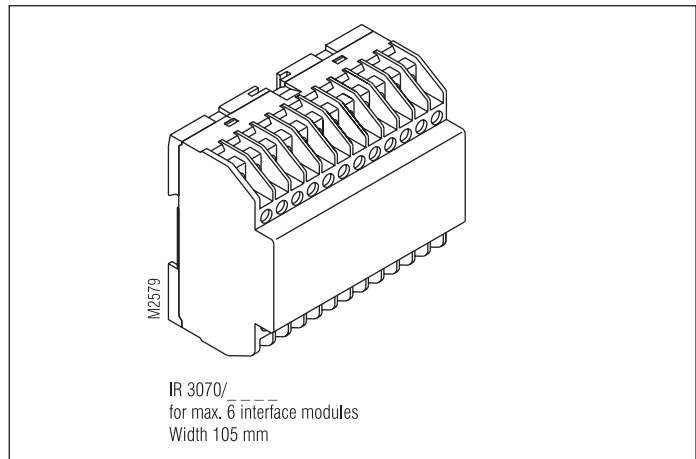
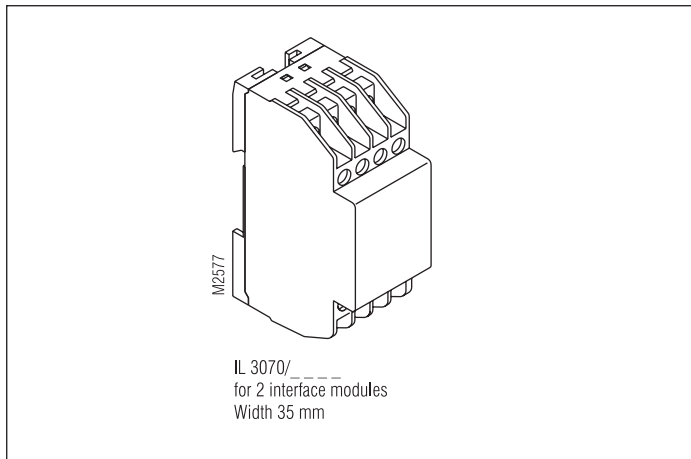

# Enquiry form for interface Relay System I\_ 3070

Production type no.

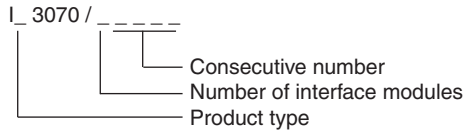

Connection terminals								
↓	Activation possibilities							Nominal voltage
A11								
A12								
A13								
A14								
A15								
A16								
A17								
A18								

Reference potential connections								
A21								
A22								
A23								
A24								
A25								
A26								
A27								
A28								

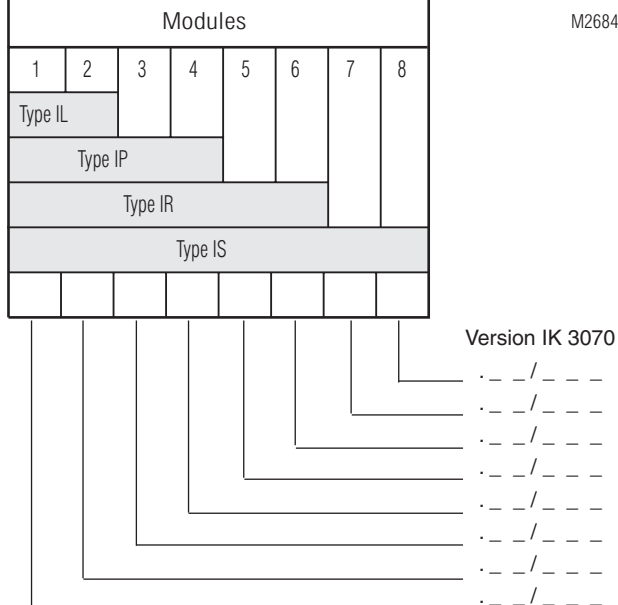

Further requests  
(e.g. connections between output contacts):

.....

.....

.....

.....

# Ordering Example

Production type no.

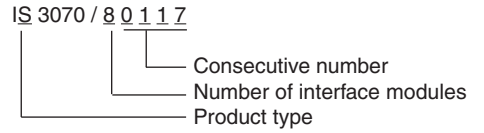

**Assignment:**

A coupling relay system consisting of the following 8 coupling modules is required:

- Module 1: for DC 24 V, 2 N.O. contacts without operating position display
- Module 2: for DC 24 V, 2 N.O. contacts with MOV and forcibly guided contacts
- Module 3: for DC 24 V, 1 N.O. contact with recovery diode
- Module 4: for AC 230 V, 1 changeover contact with MOV and recovery diode
- Module 5: for AC 230 V, 1 changeover contact without operating position display
- Module 6: for DC 24 V, 1 N.O. contact with MOV and without operating position display
- Module 7: for DC 24 V, 2 N.O. contacts, forcibly guided contacts, MOV and recovery diode
- Module 8: for DC 24 V, 2 N.O. contacts, for small loads, MOV and recovery diode

Activation of modules 1 + 2 via A11  
 Activation of module 3 via A13  
 Activation of modules 4 + 5 via A14 AC 230 V  
 Activation of modules 6 + 7 + 8 via A16 DC 24 V  
 The (-) connections of the DC 24 V modules are to be made via a joint connection terminal (A21). A joint neutral conductor connection of the AC 230 V modules must be provided via a further connection terminal (A 24).

Connection terminals								
↓	Activation possibilities							Nominal voltage
A11	X	X						DC 24 V
A12								
A13			X					DC 24 V
A14				X	X			AC 230 V
A15								
A16						X	X	DC 24 V
A17								
A18								

Reference potential connections								
A21	X	X	X			X	X	DC 24 V
A22								
A23								
A24				X	X			N
A25								
A26								
A27								
A28								

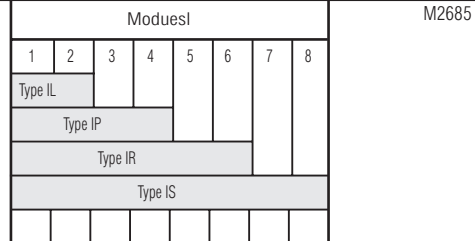

- Variant IK 3070
- ..0 2 / 1 0 A
  - ..0 2 / 0 1 A
  - ..0 1 / 0 0 B
  - ..1 1 / 0 0 2
  - ..1 1 / 0 0 A
  - ..0 1 / 0 0 8
  - ..0 2 / 0 1 1
  - ..0 2 / 0 0 2

