

VARIMETER RCM Residual Current Monitor IL 5882, SL 5882, IR 5882



Your advantages

- Compact design
- As option with external or internal residual current transformer

Features

- According to IEC/EN 62 020
- for AC and pulsating DC currents Type A to IEC/TR 60755
- 9 tripping values from 10 mA to 10 A or from 10 mA ... 30 A
- Frequency range 20 ... 2000 Hz
- Selection of manual or automatic reset
- With prewarning
- With test and reset button
- Broken wire detection
- Short reaction time
- With adjustable delay t_v
- De-energized on trip
- LED indication for auxiliary supply and state of contact
- 2 x 1 changeover contact
- With sealable cover
- Devices available in 3 enclosure versions:

IL 5882: 63 mm deep with terminals near to the bottom to be mounted in consumer units or industrial distribution systems according to DIN 43 880

- width 35 mm

- for connection of external residual current transformer, e. g. DOLD ND 5016, ND5019

SL 5882: 100 mm deep with terminals near to the top to be mounted in cabinets with mounting plate and cable ducts

- width 35 mm

- for connection of external residual current transformer, e. g. DOLD ND 5016, ND5019

IR 5882: 63 mm deep with terminals near to the bottom to be mounted in consumer units or industrial distribution systems according to DIN 43 880

- width 105 mm

- with internal residual current transformer

Function Diagram

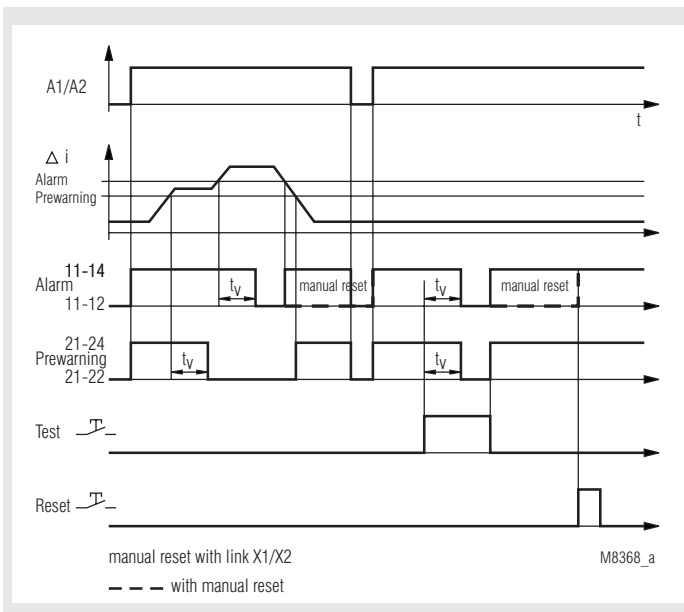

Approvals and Markings



Application

Detection of insulation faults in grounded voltage systems. The residual current relay is used to maintain electrical plants before faults occur. Decrease in insulation can be detected and indicated early without interruption of operation.

Function

The function of the IL/SL 5882 and IR 5882 can be compared to a fault current circuit breaker unit. It detects and indicates residual currents, but does not disconnect.

The measurement is done by an external residual current transformer e. g. ND 5016 which is connected via terminals i and k to the IL/SL 5882. At the device IR 5882 the residual current transformer is integrated. All conductors of the voltage system to be monitored are run through the CT except the ground wire. In a fault free voltage system the sum of all current is 0 and the CT induces no secondary voltage. If due to an insulation fault a fault current flows to ground, the current difference in the CT creates a measuring current, which is detected and measured by the IL/SL 5882 or IR 5882. A broken wire in the sensing circuit would disable the measurement, therefore a special circuit detects broken wire and forces the unit to trip.

The unit has 2 x 1 changeover contacts. Contact 11-12-14 for alarm (AL) and 21-22-24 for prewarning (VW). Prewarning is detected at 70 % of the selected alarm value. With external bridge X1-X2 the alarm is stored and has to be reset by pressing the reset button or by disconnecting the auxiliary supply. Without bridge X1-X2 the unit works with auto-reset and the fault is not stored. With the button "Test" a fault can be simulated (Alarm). Each contact is delayed with an adjustable time delay t_v (same delay time for alarm and pre-warning).

To avoid unauthorised adjustment of the potentiometers the unit has a transparent cover that could be sealed with laquer. Two holes above the push buttons allow activation of test and reset.

Circuit Diagrams

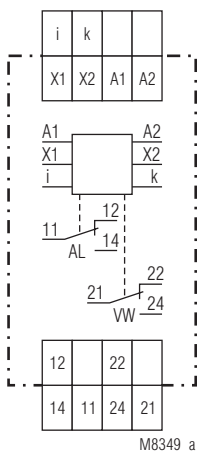

IL /SL 5882

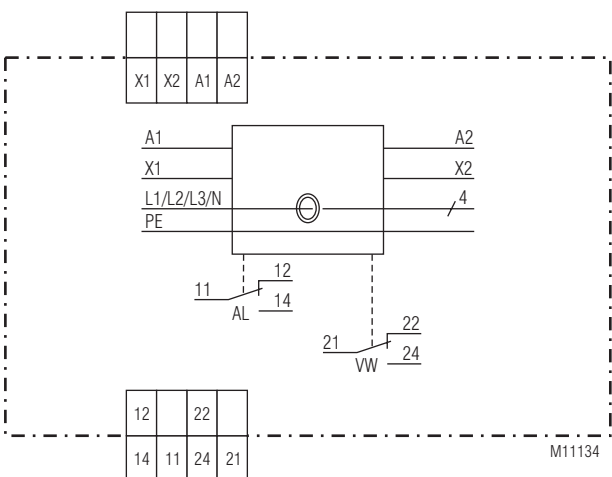

IR 5882

Connection terminals

Terminal designation	Signal designation
A1, A2	Auxiliary voltage
i, k (only at IL/SL 5882)	Conn. f. external current transformer ND5016, ND5019 ; terminals i, k
X1, X2	control input X1/X2 bridged: with manual reset of alarm X1/X2 not bridged: without manual reset of alarm (Hysteresis function)
11, 12, 14	1. C/O contact (Alarm)
21, 22, 24	1. C/O contact (Pre-warning)

Indication

green LED "ON": on, when supply connected
red LEDs "VW", "AL": on, when insulation failure (prewarning and alarm)

Note

If time is set to 0 and a pulsating fault current is flowing (e.g. 1-way rectified) the output relay may flicker because of the short reaction time. By increasing the time delay this effect can be avoided.

Setting

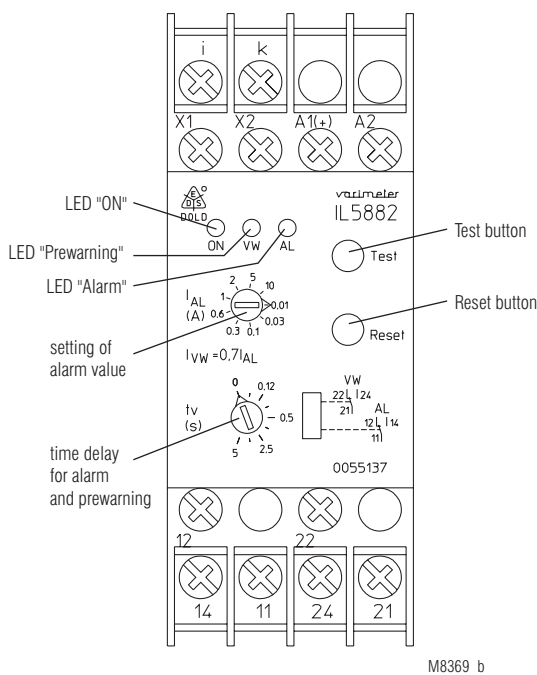

Technical Data

Input

Auxiliary voltage U_H:	AC/DC 12 V, AC/DC 24 ... 230 V
Voltage range:	
AC:	0.8 ... 1.1 U_N
DC:	0.9 ... 1.25 U_N
Nominal frequency U_H:	50 ... 400 Hz
Nominal consumption	
AC 230 V:	4 VA
AC 24 V:	1.6 VA
DC 24 V:	1 W
Measuring value adjustable via rotational switch:	AC 0.01; 0.03 A; 0.1 A; 0.3 A; 0.6 A 1 A; 2 A; 5 A; 10 A or AC 0,01 A, 0,03 A; 0,1 A; 0,3 A; 0,6 A 1 A; 2 A; 7 A; 30 A
Frequency range:	20 Hz ... 2 kHz at failure current < 50 Hz and the function "auto reset", a time delay must be adjusted, so that the relay does not buzz before switching
Hysteresis:	approx. 4% of trip value, fixed
Accuracy:	$\leq \pm 15\%$
Repeat accuracy:	$\leq \pm 1\%$
Temperature drift:	$\leq \pm 0.05\%$ / K
Reaction time:	10 ... 30 ms
Response delay t_v:	0 ... 5 s adjustable (logarithmic scale in order to allow also short time delay to be adjusted without problems)

Output

Contacts:	
IL / SL / IR 5882.38:	1 changeover contact for Prewarning, 1 changeover contact for Alarm
Thermal current I_{th}:	5 A
Switching capacity	
to AC 15:	
NO contact:	3 A / AC 230 V EN 60 947-5-1
NC contact:	1 A / AC 230 V EN 60 947-5-1
Electrical life	
to AC 15 at 1 A, AC 230 V:	3 x 10 ⁵ switching cycles EN 60 947-5-1
Short circuit strength	
max. fuse rating:	4 A gL EN 60 947-5-1
Mechanical life:	$\geq 10^8$ switching cycles

General Data

Operating mode:	Continuous
Temperature range:	- 20 ... + 60°C
Clearance and creepage distances	
rated impulse voltage / pollution degree supply / contacts:	4 kV / 2 IEC 60 664-1
supply / Measuring Circuit:	corresponding to CT
EMC	
Surge voltages:	class 3 (5 kV / 0.5 J) DIN VDE 0435-303
HF-interference:	class 3 (2.5 kV) DIN VDE 0435-303
Electrostatic discharge:	8 kV (air) IEC/EN 61 000-4-2
HF irradiation	IEC/EN 61 000-4-3, EN 50 121-3-2
80 MHz ... 1 GHz:	20 V / m
1 GHz ... 2,7 GHz:	10 V / m
Fast transients:	4 kV (class 3) IEC/EN 61 000-4-4
Surge voltages:	2 kV (class 3) IEC/EN 61 000-4-5
Interference suppression:	Limit value class B EN 55 011
Degree of protection:	
Housing:	IP 40 IEC/EN 60 529
Terminals:	IP 20 IEC/EN 60 529
Housing:	Thermoplastic with V0-behaviour according UL subject 94
Vibration resistance:	Amplitude 0.35 mm frequency 10 ... 55 Hz IEC/EN 60 068-2-6
Climate resistance:	20 / 060 / 03 IEC/EN 60 068-1

Technical Data

Terminal designation:	EN 50 005
Wire connection:	2 x 2.5 mm ² solid or 2 x 1.5 mm ² stranded wire with sleeve DIN 46 228-1/-2/-3/-4
Wire fixing:	Flat terminals with self-lifting clamping piece IEC/EN 60 999-1 DIN rail IEC/EN 60 715
Mounting:	
Weight	
IL 5882:	approx. 125 g
SL 5882:	approx. 150 g
IR 5882:	approx. 300 g

Dimensions

Width x height x depth:	
IL 5882:	35 x 90 x 63 mm
SL 5882:	35 x 90 x 100 mm
IR 5882:	105 x 90 x 63 mm (inner diameter current transformer: 21.5 mm)

Standard Types

IL 5882.38 AC/DC 24 ... 230 V 50 / 60 Hz 10 A 5 s
Article number: 0055138

- De-energized on trip
- Auxiliary voltage U_H : AC/DC 24 ... 230 V
- Measuring range: 10 A
- Response delay t_v : 5 s
- Width: 35 mm

SL 5882.38 AC/DC 24 ... 230 V 50 / 60 Hz 10 A 5 s
Article number: 0055515

- De-energized on trip
- Auxiliary voltage U_H : AC/DC 24 ... 230 V
- Measuring range: 10 A
- Response delay t_v : 5 s
- Width: 35 mm

IR 5882.38 AC/DC 24 ... 230 V 50 / 60 Hz 10 A 5 s
Article number: 0066143

- Internal residual current transformer (\varnothing 21.5 mm)
- De-energized on trip
- Auxiliary voltage U_H : AC/DC 24 ... 230 V
- Measuring range: 10 A
- Response delay t_v : 5 s
- Width: 105 mm

ND 5016/024

Article number: 0066009
• Residual current transformer for IL/SL 5882
• Diameter: 24 mm
• DIN-rail mounting: waagrecht oder senkrecht
• Screw mounting: M4

Variant

IL 5882.12/002:	with 2 changeover contacts for alarm and no pre-warning
-----------------	---

Ordering example for variant

IL 5882 .38 / _ _ _ AC/DC 24 ... 230 V 50/60 Hz 10 A 5 s

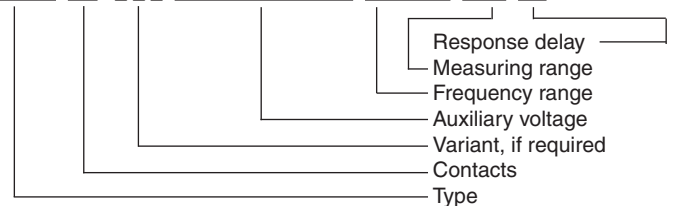

Residual Current Transformer ND 5016

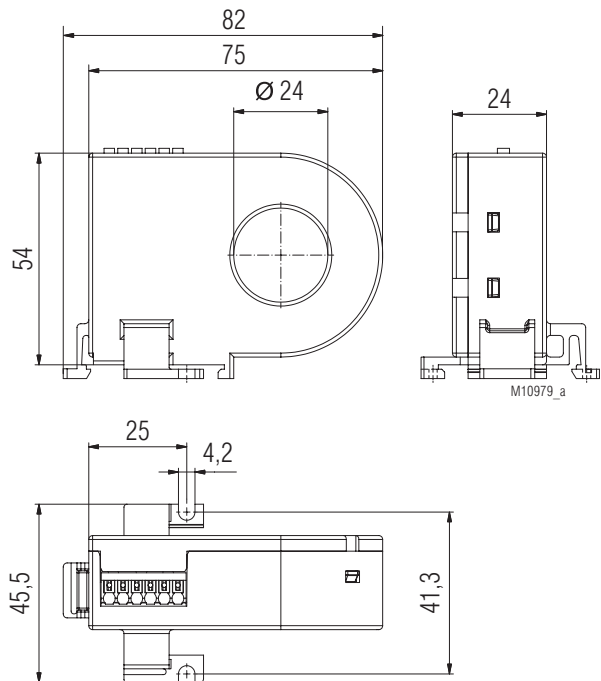

for DIN rail mounting or screw mounting

	ND 5016/024
Art-No.	0066009
kg	0.08

Technical Data

Ambient temperature

ND 5016: - 20 ... + 60°C / 253 K ... 333 K
 ND 5019: - 10 ... + 50°C / 263 K ... 323 K

Inflammability class:

V0 according to UL94

Nominal insulation voltage

acc. to IEC 60 664-1: AC 630 V

Rated impulse voltage /

pollution degree: 6 kV/3

Voltage test acc. to

DIN VDE 0435-303 /
IEC/EN 60 255: AC 3 kV

Transformation ratio:

500 /1

Length of connection wires

Type of wire:

Single wire: up to 1 m
 Single wire Twisted pair: up to 10 m
 Screened wire;
 screen on terminal k: up to 25 m

Wire cross section

ND 5016: 0,2 ... 1,5 mm²
 ND 5019: 0,75 mm²

Stripping length:

8 mm

Wire fixing

ND 5016: Terminals with spring connection and direct (Push in) technology
 ND 5019: Box terminals

Screw connection:

ND 5016/024: M4
 ND 5019/035, ND 5019/070,
 ND 5019/105: M 5

DIN rail mounting:

ND 5016: integrated clips for vertical and horizontal mounting
 ND 5019: using mounting adapter ET 5018

Residual Current Transformer ND 5019

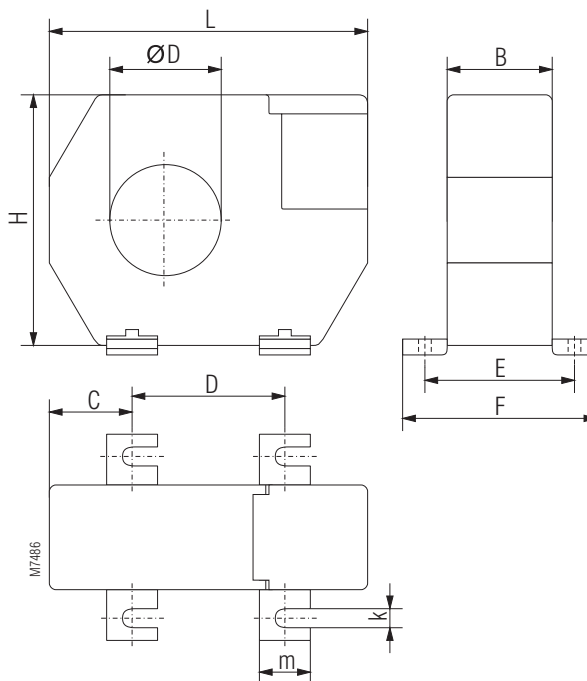

for Screw connection

Dimensions in mm			
	ND 5019/035	ND 5019/070	ND 5019/105
Art-No.	0055116	0055117	0055118
øD	35	70	105
L	100	130	170
B	33	33	33
H	79	110	146
C	26	32	38
D	48.5	66	94
E	46	46	46
F	61	61	61
k	6.5	6.5	6.5
m	16	16	16

Weight			
	ND 5019/035	ND 5019/070	ND 5019/105
kg	0.15	0.24	0.5

The residual current transformers ND 5019/035, ND 5019/070, ND 5019/105 can also be mounted on DIN-rail. To do this the metal screw fixings have to be removed and have to be replaced by 2 mounting clips (ET5018: art. no. 0058754; set with 2 pcs)

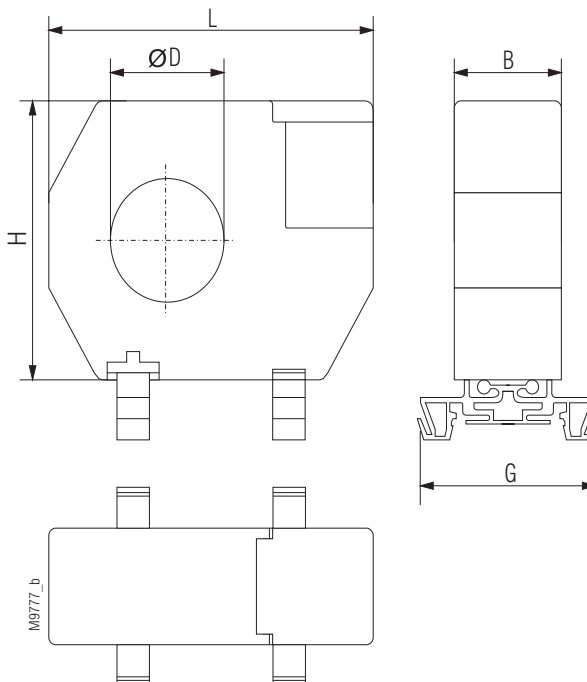

Disassembling Residual Current Transformer ND 5016

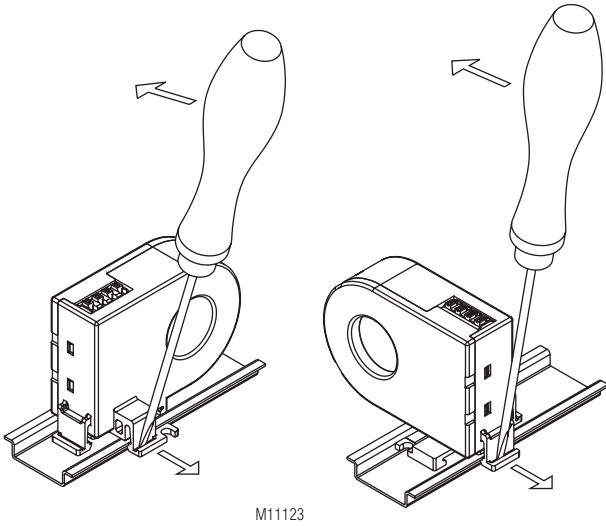

M11123

Connection Example

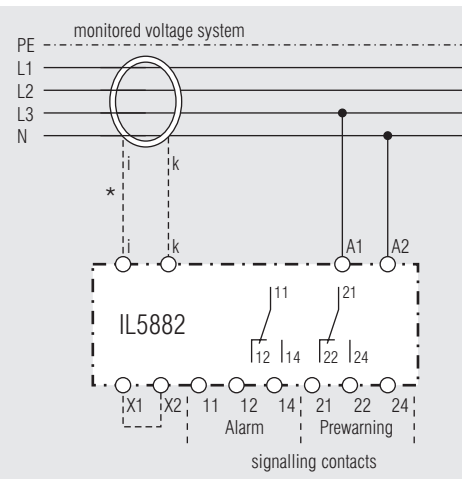

X1-X2 open : automatic reset
X1-X2 closed : manual reset

M8370_c

* only IL5882, SL5882

Installation of Wires

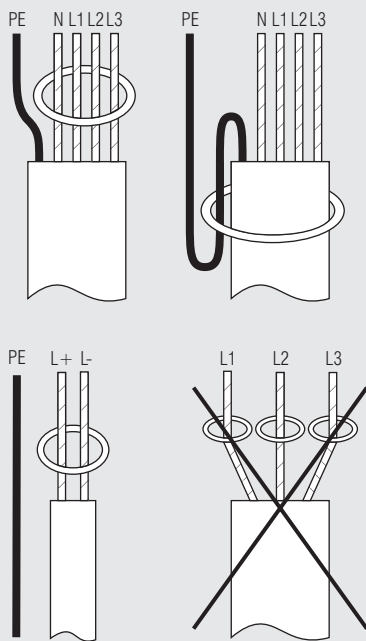

M8362_a



Attention:

As the auxiliary supply has no galvanic separation, the secondary circuit of the CT must not be connected to ground. A ground connection will lead to a damage of the unit!

To Avoid Interference with High Starting Currents

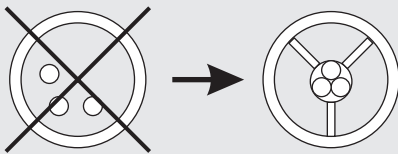

M8363

