

MINIMASTER Output Module for CANopen IP 5503

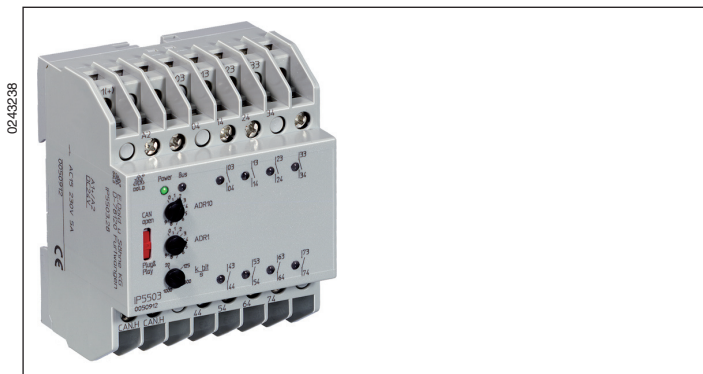

- According to IEC/EN 61 131-2, IEC/EN 50 178
- CANopen interface according to DS301 version 3.0 (Plug and Play selectable), as option with galvanic separation
- 8 relay outputs
- LED indicators for supply voltage, Bus status and state of contact
- 70 mm width

Circuit Diagram

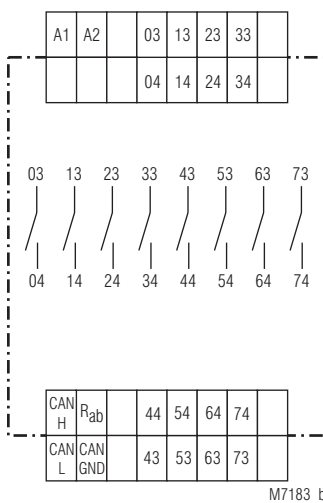

M7183_b

IP 5503.28

Additional Information

- Datasheet Input Module IP 5502
- Datasheet Emergency Off Monitor BH 5922
- Datasheet MINIMASTER IL 5504, IN 5504
- Datasheet Power Supply IR 5592
- Datasheet Analogue Input Module IL 5508
- Datasheet Analogue Output Module IL 5507

Approvals and Markings



Application

The digital output module actuates signals in control circuits. The modul is used in industrial control circuits and building automation.

Indicators

- yellow LED „Power“: on, when supply connected
- yellow LED „BUS“: on, when bus is active
- red LEDs: on, when output relay is active (8 LEDs)

Setting and Adjustment

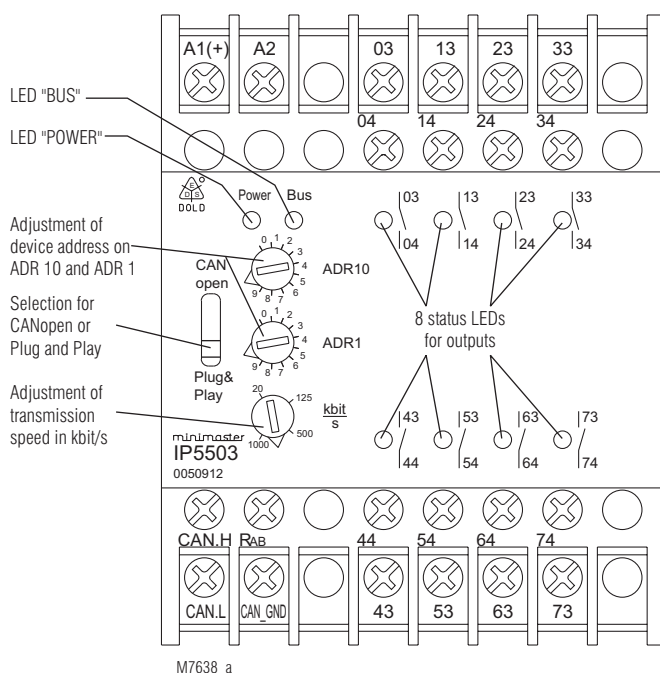

M7638_a

CANopen operation

With switch in position "CANopen" the CAN bus runs the CANopen protocol. The configuration is made with the programming software PN 5501 in conjunction with minimaster IL 5504 / IN 5504 or e.g. with ProCANopen. The corresponding configuration file on CD can be ordered under order no. PN 5501, article no. 0052860

Plug and Play operation

With switch in position "Plug and Play" the CANopen bus runs a variant for the CANopen protocol and allows only to operate Dold modules that have this feature. If a system is configured in Plug and Play operation, it can be altered to CANopen at any time.

Address setting in Plug and Play mode

To allow the input module to communicate via CAN bus with a corresponding device, the address has to be adjusted on the 2 rotational switches on the front see below: The addresses 1 ... 49 and 51 ... 99 can be chosen. In Plug and Play mode the addresses 0 and 50 do not exist.

Input module IP 5502 with address	transmits to	Output module IP 5503 with address
1	→	51
.		.
49	→	99

Example of setting:
Upper rotational switch "ADR 10": address 14
Lower rotational switch "ADR 1": in position 1

Setting and Adjustment

Set-up procedure

- 1.) Connect device to CANopen-bus
- 2.) Terminate bus on both ends with bridge between CAN-H and R_{ab} on first and last module.
- 3.) Adjust transmission speed (e. g. 20 K bit / s)
- 4.) Adjust device addresses

Attention:



To allow transmission in Plug and Play mode, one of the input modules e.g. IP 5502 of the CAN-bus has to be set to address 1.

Technical Data

Auxiliary voltage

Auxiliary voltage U_H A1/A2: DC 24 V
Voltage range: 0,8 ... 1,1 U_N
Nominal consumption: 0,5 W

Output

Contacts:

IP 5503.28: 8 NO contacts IEC/EN 61 131-2
Thermal current I_{th}: 2 A

Switching capacity

to AC 15: 3 A / AC 230 V IEC/EN 60 947-5-1
Switching capacity:
at DC 24 V: 48 W
at AC 230 V: 460 VA

Short circuit strength

max. fuse rating: 4 AgL IEC/EN 60 947-5-1
Mechanical life: > 10⁸ switching cycles

CANopen interface

IP 5503.28/100: galvanic separation according to ISO 11 898-1
Wire : screened twisted pair
Transmission speed: adjustable 20 K bit/s, 125 K bit/s, 500 K bit/s, 1 M bit/s,
20 K bit/s = 2.500 m
125 K bit/s = 500 m
500 K bit/s = 100 m
1 M bit /s = 25 m

Plug and Play

Transmission speed: 20 K bit / s (recommended)

Attention:



Both ends of the 2-wire bus have to be terminated with a bridge between CAN_H and R_{ab}.

Operating mode: Continuous operation

Temperature range: - 20 ... + 60°C

Clearance and creepage distances

rated impulse voltage / pollution degree: 4 kV / 2 IEC 60 664-1

EMC

Electrostatic discharge: 8 kV (air) IEC/EN 61 000-4-2
HF-irradiation: 10 V/m IEC/EN 61 000-4-3
Fast transients: 2 kV IEC/EN 61 000-4-4

Surge voltages between

wires for power supply: 1 kV IEC/EN 61 000-4-5
between wire and ground: 2 kV IEC/EN 61 000-4-5
Interference suppression: Limit value class B EN 55 011

Degree of protection

Housing: IP 40 IEC/EN 60 529
Terminals: IP 20 IEC/EN 60 529

Housing: Thermoplastic with V0-behaviour according to UL subject 94

Vibration resistance: amplitude 0,35 mm
frequency 10 ... 55 Hz IEC/EN 60 068-2-6
20 / 060 / 04 IEC/EN 60 068-1

Climate resistance: EN 50 005

Terminal designation: EN 50 005
Wire connection: 2 x 2,5 mm² solid or
2 x 1,5 mm² stranded wire with sleeve
DIN 46 228-1/-2/-3/-4

Wire fixing: Flat terminals with self-lifting clamping piece IEC/EN 60 999-1

Technical Data

Mounting: DIN rail IEC/EN 60 715
Weight: 225 g

Dimensions

Width x height x depth: 70 x 90 x 61 mm

Standard Type

IP 5503.28 DC 24 V
Article number: 0050912
• 8 relay outputs
• Nominal voltage U_N: DC 24 V
• Width: 70 mm

Ordering Example

IP 5503.28/ 00 DC 24 V

Bus interface

0 CANopen interface without galvanic separation

1 CANopen interface with galvanic separation

Accessories

- CANopen PLC IL 5504
- Input / Output module IN 5509
- Input module, digital IP 5502
- Output module, digital IP 5503
- Input module, analogue IL 5508
- Output module, analogue IL 5507

Application Examples

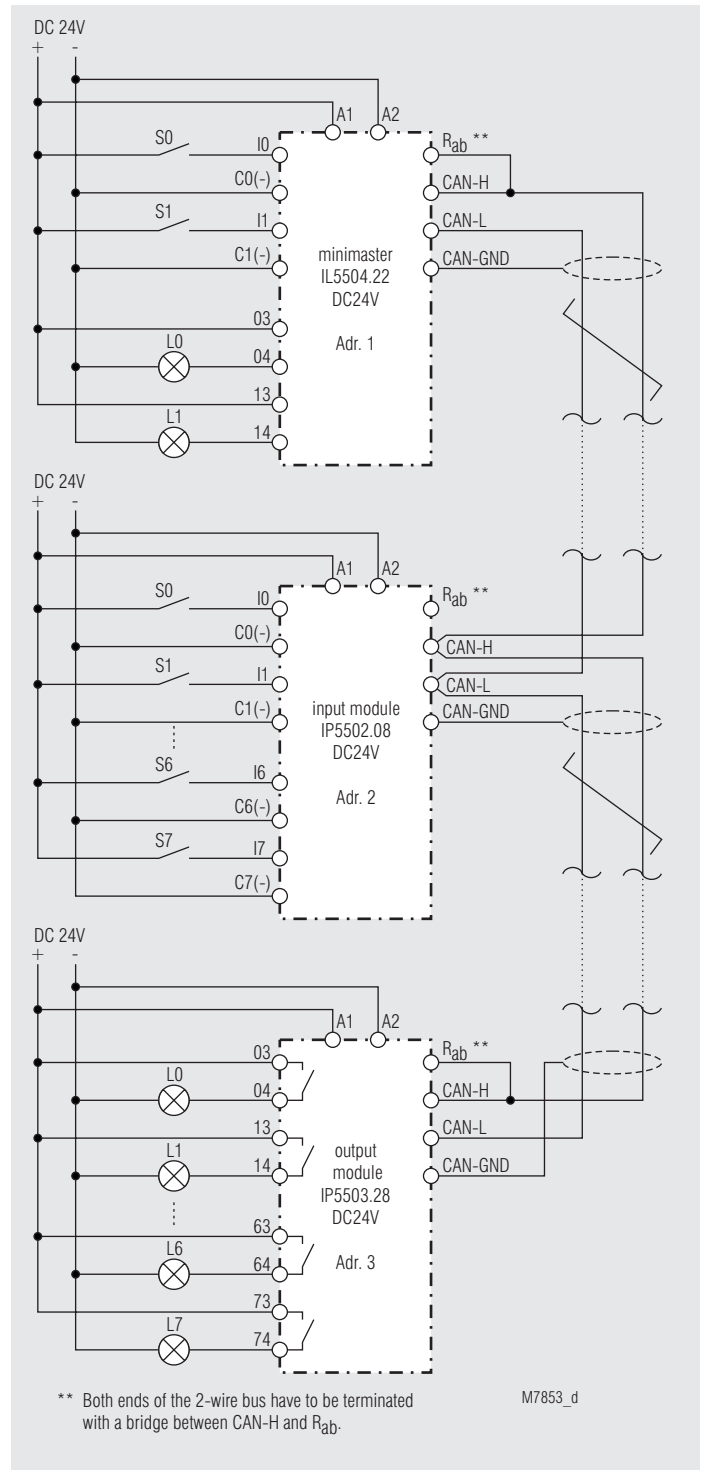
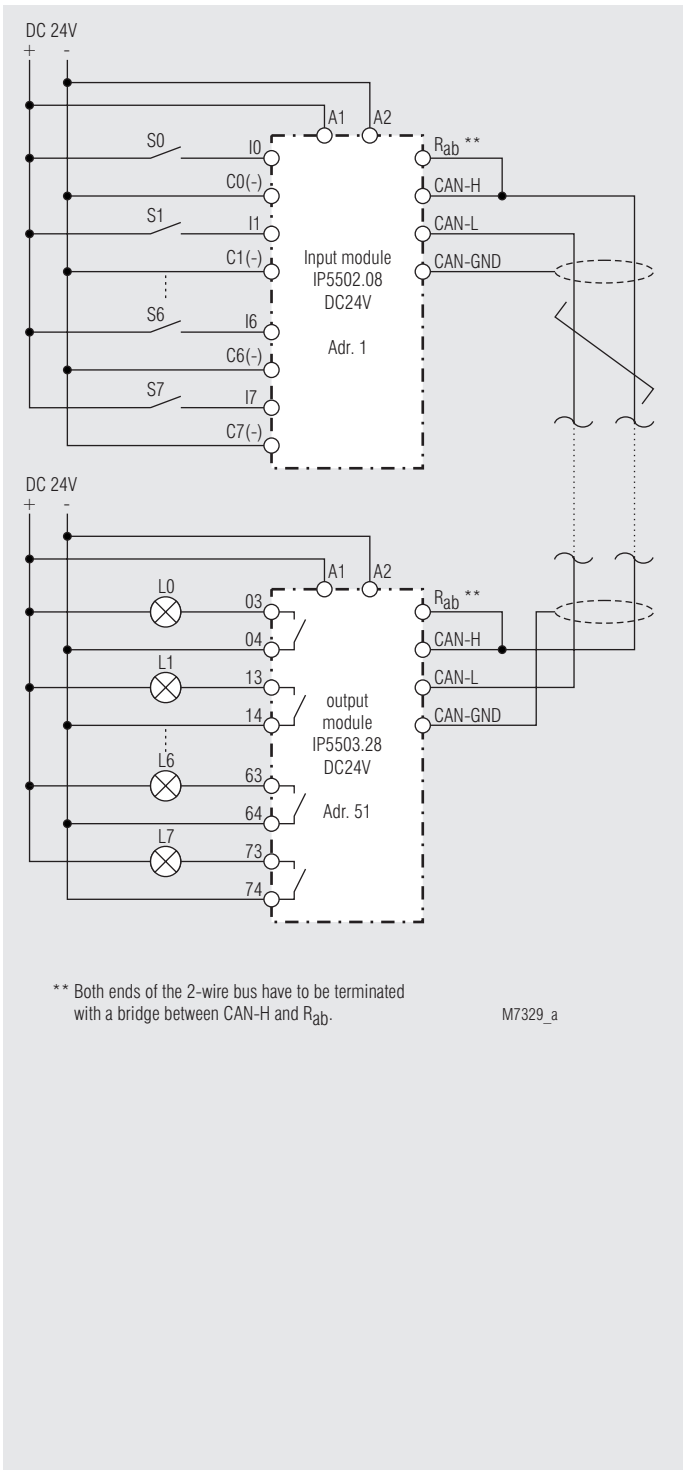

Design of a 2-wire remote control is very simple:
 Connect input module IP 5502 to output module IP 5503 via a 2-wire line
 adjust addresses and speed ... ready to go.

Application example

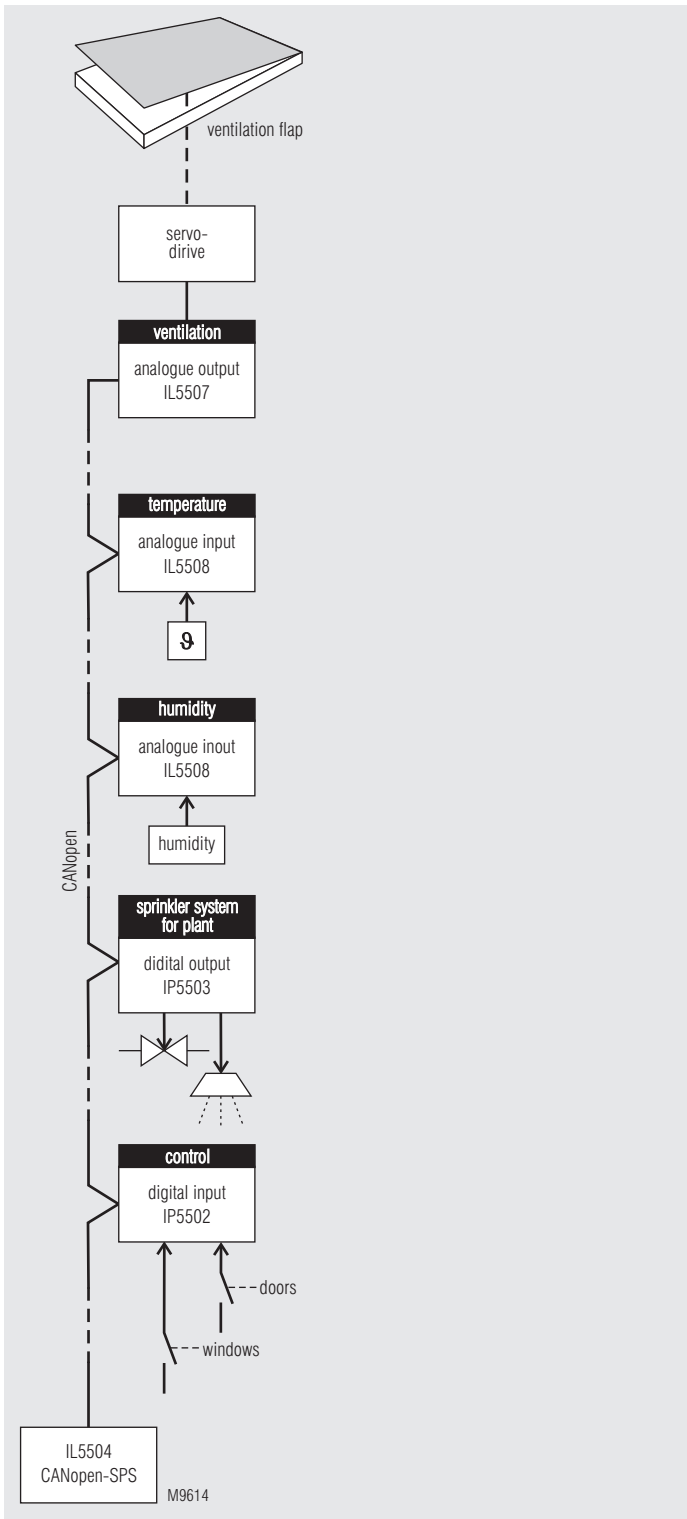

CANopen-application for greenhouses:
depend on temperature- and humidity ventilation flap applications and
sprinkler systems for plants in a greenhouse.