



Your Advantages

- Preventive fire and system protection
- Quick fault localisation through selective earth fault detection to L+ and L-
- Universal application in non-earthed DC / AC and mixed IT networks with up to 690 V nominal voltage
- Suitable for large leakage capacitances up to 1000 μF
- Simplest setting via engaging rotary switches
- Optimised measuring times - normally shorter than with known methods
- Monitoring also with voltage-free mains
- Measuring circuit with broken wire detection
- No additional ballasting required

Features

- Insulation monitoring according to IEC/EN 61557-8
- Detection of symmetric and asymmetric insulation faults
- 2 changeover contacts
- Prewarning threshold setting range: 20 k Ω ... 2 M Ω
- Alarm threshold setting range: 1 k Ω ... 250 k Ω
- Energized or de-energized on trip can be selected for output relay
- Setting the maximum leakage capacitance to shorten the response time
- Simple, clearly arranged adjustment of the device with screwdriver
- LED chain to indicate the current insulation resistance
- Display of active measuring circuits
- Automatic and manual device self-test
- Width: 90 mm

Circuit Diagram

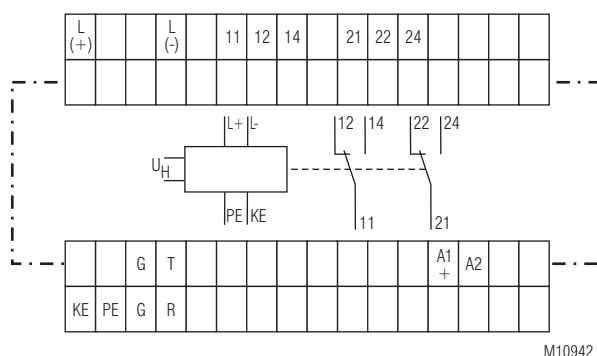

Approvals and Marking



Connection Terminals

Terminal designation	Signal designation
A1+, A2	DC-Auxiliary voltage
L(+), L(-)	Connection for measuring circuit
KE, PE	Connection for protective conductor
G, R	Control input (manual/auto reset) G/R not bridged: manual reset G/R bridged: auto reset
G, T	Control input (External test input) connection option for external device test pushbutton
11, 12, 14	Alarm signal relay (1 changeover contact)
21, 22, 24	Prewarning signal relay (1 changeover contact)

Applications

- Insulation monitoring of:
- Non-earthed DC / AC and mixed IT networks
 - UPS systems
 - Networks with frequency inverters
 - Battery networks
 - Networks with direct current drives
 - Photovoltaic systems
 - Hybrid and battery-powered vehicles

Function Diagram

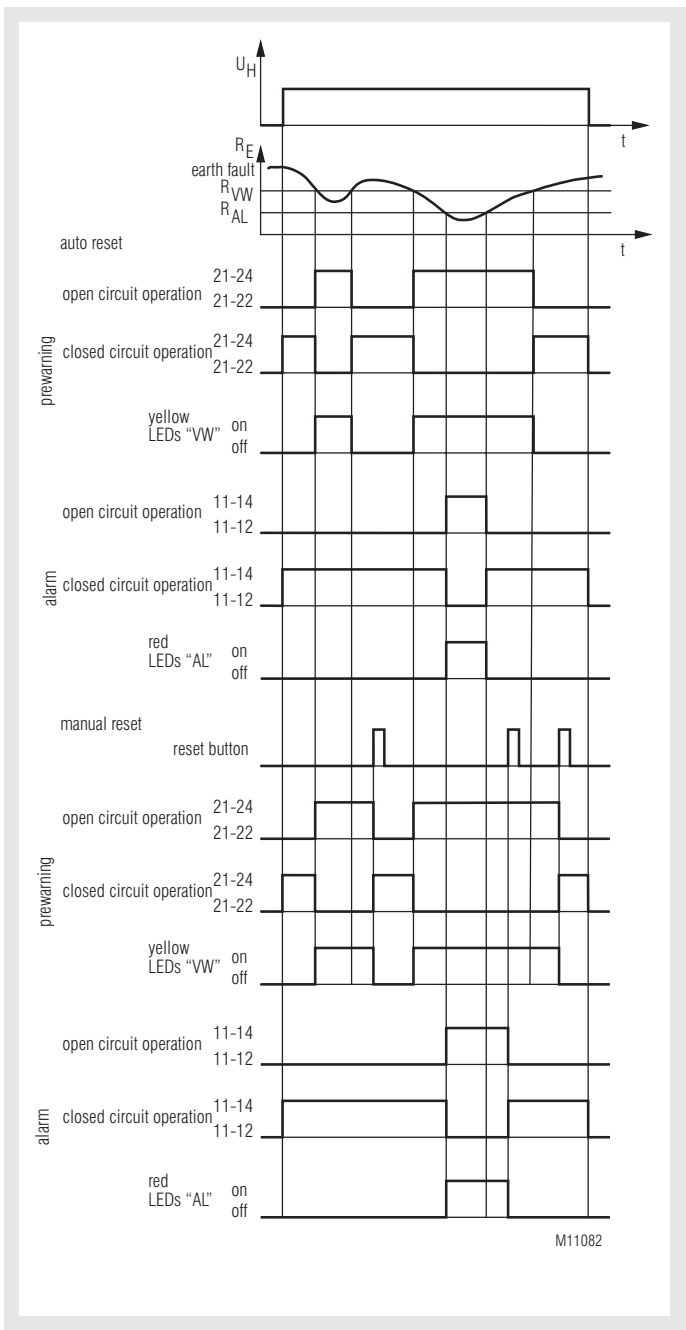

Function

If the device is supplied with DC auxiliary voltage, the a green "PWR" LED comes on. Switching on the auxiliary voltage is followed by an internal self-test for 10 sec, where the LEDs of the indicator string light up in sequence. After this, measurement of the insulation resistance in the measuring circuits begins.

Measuring circuit

(Insulation measurement between terminals L(+) / L(-) and PE / KE)

Terminals L(+) and L(-) are connected to the mains to be monitored. Broken wire detection, constantly effective during operation, generates an error messages if both terminals are not connected with low resistance through the mains.

In addition, the two terminals PE and KE must be connected to the protective conductor system via separate lines. An error message is given here as well if a line is interrupted (see section "Actions in case of connection faults").

If the main measuring circuit is activated, an active measuring voltage with alternating polarity is applied between L(+) / L(-) and PE / KE to measure the insulation resistance. During the measuring phase with positive polarity, the "Active" LED flashes with a long On-phase and with negative polarity with a short On-phase.

The length of the positive and negative measuring phases depends on the settings on the rotary switch "CE/ μ F", the actual leakage capacitance of the monitored network and with DC networks, on the level and duration of possible mains voltage fluctuations. Correct and preferably quick measurement is thus given with different mains conditions. In the event of particularly adverse conditions and major interferences, the measuring analysis can be steadied and delayed in addition with rotary switch "tv" if necessary.

The current insulation resistance is determined and analysed at the end of each measuring phase. The LED chain show the resistance determined, and the output relays for prewarning "VW" and alarm "AL" switch according to the respective response values set. If the response thresholds have been undercut, the LEDs "VW" or "AL" light according to the insulation fault location: "+", "-" or "+" and "-" simultaneously for AC faults or symmetric insulation faults.

Storing insulation fault message

If terminal R is open, the insulation fault messages from the main and auxiliary measuring circuit are stored when the respective response value is undercut, but also when the insulation resistance returns to the OK-range. In addition, the temporary minimum values of the insulation resistance are indicated on the LED chain through dimmed LEDs.

If the "Reset" button on the device front is pressed or terminal R is connected with G, the stored insulation fault messages are reset when the insulation resistance is again in the OK-range.

Output relay for insulation fault messages

The rotary switch "CE/ μ F Rel." allows selecting the operating current (A) or standby current (R) principle for the output relays "AL" (contacts 11-12-14) and "VW" (contacts 21-22-24).

With the operating current principle, the relays respond when the response values are undercut, with the standby current principle they release when the response values are undercut.

If 2 different response values are not needed, "VW" and "AL" can be set to the same value. The output relays switch together in this case.

Broken wire detection

As mentioned above, both the main measuring circuit and the auxiliary measuring circuit are constantly monitored for wire breaks - not only at Power-On or a manual or occasional automatic test. The response time of monitoring is only a few seconds.

Broken wire detection between L(+) and L(-) is performed via coupled alternating voltage. This alternating voltage is short-circuited if the terminals are connected to the connected mains at low-resistance. The device detects that the mains to be monitored is properly connected. Since this broken wire detection is carried out with alternating voltage, large capacitances should be avoided between L(+) and L(-), since the capacitive reactance of these capacitances also short-circuits this alternating voltage. The device would no longer detect a connection fault on L(+)/L(-). Especially parallel lines should be prevented over larger distances.

If larger capacitances between L(+)/L(-) cannot be avoided or if the coupled alternating voltage interferes with the system, version LK 5894.12/011 (without broken wire detection on L(+)/L(-)) shall be used.

Flashing Codes LED "ERR"

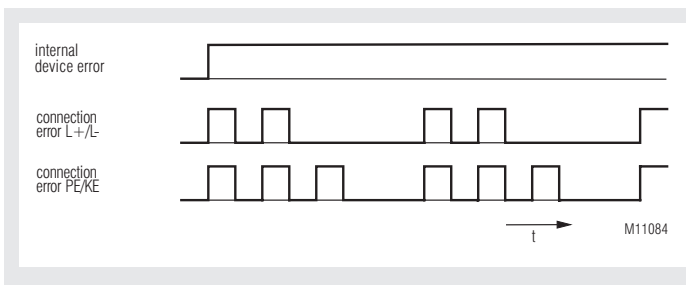

Function

Device test functions

Principally, 2 different test functions are implemented: The "self-test" and the "expanded test":

The self-test of the device is performed automatically after Power-On and every 4 operating hours. It can also be triggered manually at any time by pressing the "Test" button at the device front or with an external pushbutton connected between terminals T and G.

With the self-test, contrary to the expanded test, the status of the output relays and the analogue output are not affected; the sequence is as follows:

Switching to the negative measuring phase is performed for 4 sec. The „Active“ LED flashes here with a brief On-phase. The LEDs of the LED chain are selected in sequence and the internal circuit is checked. After this, switching to the positive measuring phase is performed for 4 sec. The „Active“ LED flashes here with a long On-phase. The LED chain cycles again and additional internal tests are performed. Insulation measurement continues normally after a pause of 2 sec if no faults have occurred.

The expanded test is started when the internal or external "Test" button is pressed (or is still held) at the end of the 8 sec self-test, described above. The sequence is the same as with the self-test (2 measuring phases at 4 sec + 2 sec pause); however, the output relays "AL" and "VW" as well as the associated LEDs switch to the alarm state and the analogue output proceeds to its lowest value.

If the Reset button is pressed during the 8 sec or terminals R-G are connected, the expanded test is terminated after these 8 sec. Otherwise, the phases of the expanded test are constantly repeated, where, in addition, the "ERR" LED and the fault signalling relay (contacts 31-32-34) constantly receive current. However, the expanded test is terminated as soon as the Reset button is pressed. The device switches to the OK-state and restarts insulation measurement.

Behaviour with internal device faults

If internal device faults were detected during the test function, the "ERR" LED is lit continuously and the measuring circuit is deactivated internally ("Active" LED goes off). The output relays "AL" and "VW" as well as the associated LEDs switch to the alarm state and all LEDs of the LED chain extinguish.

Behaviour with connection faults

Measurement is suspended if a line interruption is detected at terminals L(+) / L(-); the "Active" LED goes off. The state of the output relays "AL" / "VW" and associated LEDs, the display of the LED chain and the analogue output are "frozen". This Broken wire detection is signalled by the "ERR" LED flashing with "Error code 2" and the fault signalling relay responds. Measurement of the connection insulation resistance restarts after the connection interruption has been corrected. However, stored alarm messages are preserved.

If the connections PE / KE to the protective-conductor system are interrupted, the same responses take place as with an interruption at terminals L(+) / L(-), only that the "ERR" LED indicates "Error code 3".

Indication

green LED „PWR“:	on, when auxiliary supply connected
red LED „ERR“:	permanent on: at system error flashing: at connection failure
green LED „Active“:	flashing: at active measuring circuit, ON-OFF-ratio per measurement phase: long ON period during measurement phase with positive polarity short ON period during measurement phase with negative polarity
yellow LED chain:	8 LEDs indicate the actual insulating resistance ($\leq 10 \text{ k}\Omega \dots \geq 2 \text{ M}\Omega$)
yellow LED „VW +“:	permanent on: R_E lower then prewarning value to + potential
yellow LED „VW -“:	permanent on: R_E lower then prewarning value to - potential
yellow LEDs „VW +“ and „VW -“ simultaneity:	permanent on: AC-fault / symmetric fault
red LED „AL +“:	permanent on: R_E lower then tripping value to + potential
red LED „AL -“:	permanent on: R_E lower then tripping value to - potential
red LEDs „AL +“ und „AL -“ simultaneity:	permanent on: AC-fault / symmetric fault

Notes

Device terminals PE and KE must always be connected via separate lines to different terminal points of the protective-conductor system.

The main measuring circuit can be connected with its terminals L(+) and L(-) both to the DC and also AC side of a mixed network; it is done most practically where the primary incoming power supply takes place. Selector switch "tv / U_N " should be set accordingly.

For photovoltaic systems and hybrid vehicles, the main measuring circuit of the LK 5894 is connected on the DC side; the auxiliary measuring circuit can then be used to monitor the (deactivated) AC side.

For the main measuring circuit, the nominal voltage range for DC is specified with 690 V; however, absolute values up to max. DC 1000 V are permissible.

The main measuring circuit is designed for large leakage capacitances up to 1000 μF . The selection switch "CE/ μF " must be set accordingly. Measurement of the insulation resistances is not falsified by this; however, longer periods are required for the measuring phases than with small capacitances. If the maximum approximate leakage capacitance is known, the selector switch "CE/ μF " can possibly be set to smaller values, which reduces the response time further.

The measuring circuit should not be connected via longer parallel guided wires, as this may interfere with the broken wire detection. Also large capacities between L(+) und L(-) have to be avoided.

No external potentials may be connected to control terminals "T" and "R". The associated reference potential is "G" (identical with PE), and the connection of the terminals is made via bridges to "G".

Attention !



The device must not be operated without KE/PE connection.

The voltage of the monitored voltage system is connected to terminals L(+) / L(-). Please observe sufficient distance to terminals of neighbour devices and to the grounded metal cabinet or box (min 0.5 cm).



The device monitors HIGH-VOLTAGE
Caution High-Voltage when working on the device!

Technical Data**Measuring circuit L(+)/L(-) to PE/KE**

Nominal voltage U_N:	DC 0 ... 690 V; AC 0 ... 690 V
Voltage range:	DC max. 1000 V; AC max. 760 V
Frequency range:	DC or 16 ... 1000 Hz
Max. line capacitance:	1000 μ F
Internal resistance (AC / DC):	> 280 k Ω
Measuring voltage:	approx. \pm 95 V
Max. measured current ($R_E = 0$):	< 0.35 mA

Response values R_E

Pre-warning („VW“):

k Ω :	20	30	50	70	100	150	250	500	1000	2000
--------------	----	----	----	----	-----	-----	-----	-----	------	------

Alarm („AL“)

k Ω :	1	3	10	20	30	50	70	100	150	250
--------------	---	---	----	----	----	----	----	-----	-----	-----

each adjustable via rotational switches

Response inaccuracy: \pm 15 % + 1.5 k Ω IEC 61557-8**Response value hysteresis**at range 10 k Ω ... 700 k Ω : approx. 25 %
out of range: approx. 40 % + 0.5 k Ω **On delay**at $C_E = 1 \mu$ F,
 R_E of ∞ to 0.5 * response value: < 10 s**Input auxiliary voltage****DC-Input (A1+ /A2)**

Nominal voltage U_H:	DC 24 V
Voltage range:	DC 20 ... 30 V
Nominal consumption:	max. 5 W

Control input (between T, R and G)

Current flow:	approx. 3 mA
No-load voltage to G:	approx. 12 V
Permissible wire length:	< 50 m
Min. activation time:	0.5 s

Output

Contacts:	2 x 1 changeover contacts for VW and AL
Thermal current I_{th}:	4 A
Switching capacity to AC 15:	
NO contact:	3 A / AC 230 V IEC/EN 60 947-5-1
NC contact:	1 A / AC 230 V IEC/EN 60 947-5-1
Electrical life at 8 A, AC 250 V:	1 x 10 ⁴ switching cycles
Short circuit strength max. fuse rating:	4 A gL IEC/EN 60 947-5-1
Mechanical life:	10 x 10 ⁶ switching cycles

General Data

Operating mode:	Continuous operation
Temperature range Operation:	- 25 ... + 60 °C
Relative air humidity:	93 % bei 40 °C
Atmospheric pressure	860 ... 1600 mbar (86 ... 106 kPa)
Altitude:	< 4.000 m IEC 60 664-1

Clearance and creepage distances

rated impuls voltage / pollution degree	
Measuring circuit L(+)/L(-) to auxiliary voltage DC and relay contacts VW, AL:	8 kV / 2
Auxiliary voltage DC to relay contacts VW, AL:	8 kV / 2
Relay contact VW to relay contact AL:	4 kV / 2

Technical Data**EMC**

Electrostatic discharge (ESD):	8 kV (air)	IEC / EN 61000-4-2
HF irradiation:	10 V / m	IEC / EN 61000-4-3
Fast transients:	2 kV	IEC / EN 61000-4-4
HF-wire guided	10V	IEC / EN 61000-4-6
Interference suppression:	Limit value class A	EN 55011

Degree of protection

Housing:	IP 40	IEC/EN 60 529
Terminals:	IP 20	IEC/EN 60 529

Housing:Thermoplastic with V0 behaviour
according to UL subject 94**Vibration resistance:**Amplitude 0.35 mm IEC/EN 60 068-2-6
frequency 10 ... 55 Hz**Climate resistance:**

25 / 060 / 04 IEC/EN 60 068-1

Terminal designation::

EN 50 005

Wire connection:1 x 4 mm² solid or
1 x 2,5 mm² stranded ferruled (isolated)
or
2 x 1,5 mm² stranded ferruled (isolated)
DIN 46228-1/-2/-3-4
or
2 x 2,5 mm² stranded ferruled (isolated)
DIN 46228-1/-2/-3**Wire fixing:**Plus-minus terminal screws M3,5
terminal with wire protection**Mounting:**

DIN rail IEC / EN 60715

Weight:

approx. 500 g

Dimensions**Width x height x depth:** 90 x 90 x 121 mm**Standard Type**

LK 5894.12/010 DC 20 ... 30 V

Article number:

0065331

- Outputs: 1 changeover contact for pre-warning
1 changeover contact for alarm
- Auxiliary voltage: DC 20 ... 30 V
- Setting range pre-warning: 20 k Ω ... 2 M Ω
- Setting range alarm: 1 k Ω ... 250 k Ω
- Adjustable line capacitance
- Open- / or closed circuit operation
- Width: 90 mm

Variant

LK 5894.12/011: without wire-break detection at L(+)/L(-)

Connection examples

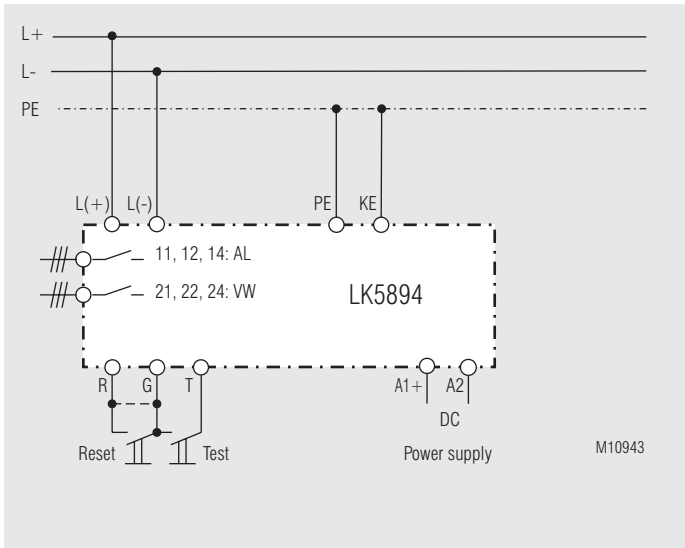

Insulation monitoring DC-side

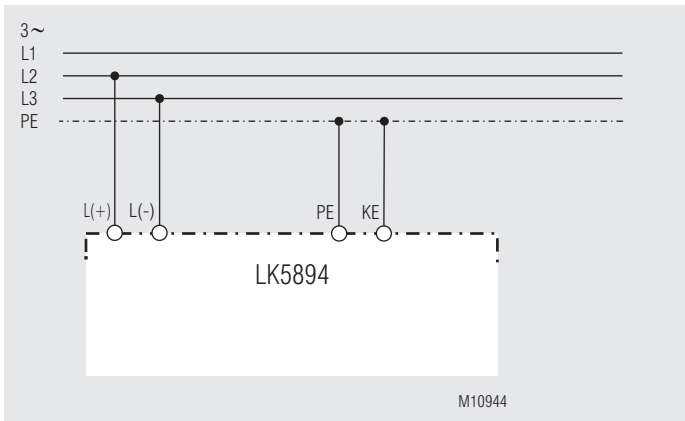

Insulation monitoring AC-side

