

- According to IEC/EN 60 255, IEC/EN 61 810-1
- Optionally safe separation according to IEC/EN 61 140, IEC/EN 60 947-1, 6 kV/2
 - between coil and contacts
 - between the two contacts
- As option with reduced power consumption
- Optionally for switching of low loads
- 1 or 2 changeover contacts
- for AC/DC 12 ... 240 V
- For 2-wire proximity sensors
- LED indicator
- Width 22.5 mm

Circuit Diagrams

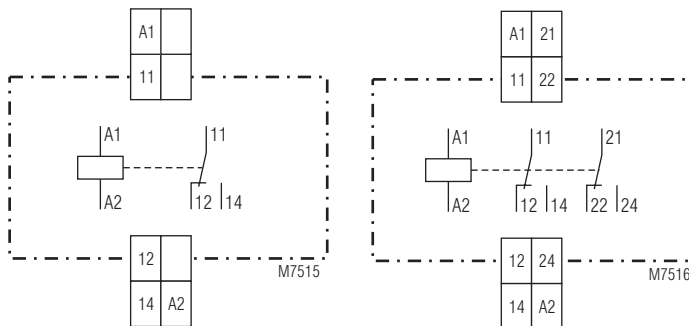

ML 3059.11

ML 3059.12
ML 3059.12/100
ML 3059.12/200

Approvals and Marking



Application

- Link between control and power levels
- For separating potentials

Indication

LED: on, when the relay is active

Technical Data

Input

Nominal voltage U_N:	AC/DC 12 ... 240 V
Voltage range:	AC 0.85 ... 1.1 U_N DC 0.9 ... 1.15 U_N
Permissible residual current:	≤ 5 mA
Nominal consumption:	DC 12 24 60 240 V 0.5 0.55 0.6 1.4 W
Nominal frequency:	50 ... 400 Hz
Frequency range:	± 5 %

Output

Contacts

ML 3059.11:	1 changeover contact
ML 3059.12:	2 changeover contacts
Operating time of contacts:	≤ 10 ms
Release time of contacts:	≤ 10 ms
Thermal current I_{th}:	5 A
Switching capacity to AC 15	
NO contact:	3 A / AC 230 V IEC/EN 60 947-5-1
NC contact:	1 A / AC 230 V IEC/EN 60 947-5-1
Electrical life to AC 15 at 3 A, AC 230 V:	5 x 10 ⁵ switching cycles
Permissible switching frequency:	6 000 switching cycles / h
Short circuit strength max. fuse rating:	6 A gL IEC/EN 60 947-5-1
Mechanical life:	> 30 x 10 ⁶ switching cycles

Technical Data

General Data

Operating mode:	Continuous operation	
Temperature range:	- 20 ... + 60 °C	
Clearance and creepage distances		
rated impuls voltage / pollution degree:	4 kV / 2	IEC 60 664-1
EMC		
Electrostatic discharge:	8 kV (air)	IEC/EN 61 000-4-2
HF-irradiation:	10 V/m	IEC/EN 61 000-4-3
Fast transients:	4 kV	IEC/EN 61 000-4-4
Surge voltages between wires for power supply:	2 kV	IEC/EN 61 000-4-5
between wire and ground:	4 kV	IEC/EN 61 000-4-5
Interference suppression:	Limit value class B	EN 55 011
Degree of protection		
Housing:	IP 40	IEC/EN 60 529
Terminals:	IP 20	IEC/EN 60 529
Housing:	Thermoplast with V0-behaviour according to UL subject 94	
Vibration resistance:	Amplitude 0.35 mm frequency 10 ... 55 Hz IEC/EN 60 068-2-6	
Climate resistance:	20 / 60 / 04 IEC/EN 60 068-1	
Terminal designation:	EN 50 005	
Wire connection:	2 x 2.5 mm ² solid or 2 x 1.5 mm ² stranded wire with sleeve DIN 46 228-1/-2/-3/-4	
Wire fixing:	Flat terminals with self-lifting clamping piece IEC/EN 60 999-1	
Mounting:	DIN rail IEC/EN 60 715	
Weight:	110 g	

Dimensions

Width x height x depth: 22.5 x 81 x 98.5 mm

Standard Type

ML 3059 .12/100 AC/DC 12 ... 240 V	
Article number:	0037230 stock item
• also for switching of low loads	
• Output:	2 changeover contacts
• Nominal voltage U_N :	AC/DC 12 ... 240 V
• Width:	22.5 mm

For switching of low loads with 0.1 ... 60 V, 1 ... 300 mA, 1 mVA ... 7 VA / 1 mW ... 7 W. The output contacts have the same switching capacity as the standard version. As the gold plating of the contacts will burn off with this switching performance, the device is not longer suitable for switching of low loads.

Safe separation according to IEC/EN 61 140, IEC/ 60 947-1, 6 kV/2

- between coil and contacts
- between the two contacts

Variants

ML 3059.11:	without gold plated contacts, with safe separation
ML 3059.12:	without gold plated contacts, without safe separation
ML 3059.12/100:	with gold plated contacts 5 µm, with safe separation
ML 3059.12/200:	Version like ML 3059.12/100 with reduced nominal consumption DC 12 V / 0.25 W; DC 24 V / 0.25 W; DC 60 V / 0.45 W; DC 240 V / 1 W Recovery time: < 50 ms

Ordering example for variants

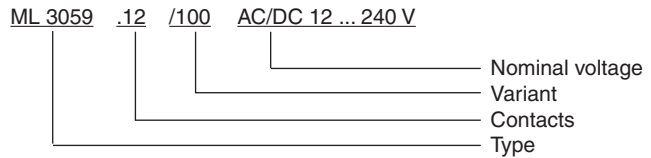

Characteristics

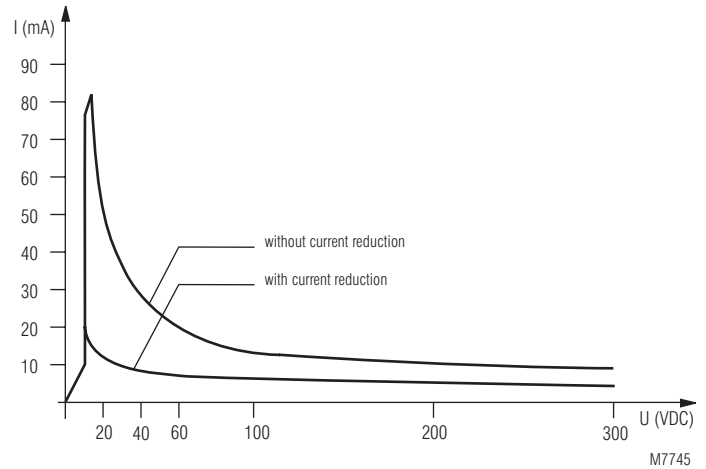

Permissible contact current of ML 3059.12/200 in relation to the auxiliary voltage.