



Your Advantage

- Easy remote control of unit via mobile phone
- Easy configuration of unit via mobile phone
- SMS-status request of all i/p's - and o/p's via configurable shortcuts
- SMS text messages via customers SIM card
- Cyclic SMS message with configurable time interval (watchdog function)

Features

- According to directive 1999/5/EC (RTTE) for radio equipment and telecommunications terminal equipment
- 4 digital inputs and 4 relay outputs
- Variant RP 5812/001 with 2 digital and 2 analogue inputs and 1 analogue - and 2 relay outputs
- Auxiliary voltage DC 24 V
- DC 24 V digital inputs
- Automatic SMS messages for status changes
- Quad-Band GSM-Module for 850, 900, 1800 and 1900 MHz (GSM = Global System for Mobile)
- Pin protection of SIM card
- Caller password protection against unauthorised access
- User Dialogue language for: German, English or French
- Configurable authorization levels for up to 16 users
- Assignment of different I/O's to different users
- Automatic sending of SMS when digital inputs change state i.e. come on or go off or both (on rising edge or falling edge)
- Automatic sending of SMS when analogue inputs
 - exceed preset lower and upper limits or
 - when signal is within the preset window
 - and when the signal returns to good state
- Adjustable
 - Hysteresis for analogue inputs
 - Time delay for each input
 - Repeat time for SMS-transmitting
 - Time delay for output status after starting the unit
 - Time delay for activation of the output
- SMS for device status to the system administrators
- SMS-counter to monitor the remaining account
- No interruption of operation after Voltage failure due to integrated Li-Ion battery backup 24Hours
- Compact width: 70 mm

Circuit Diagrams

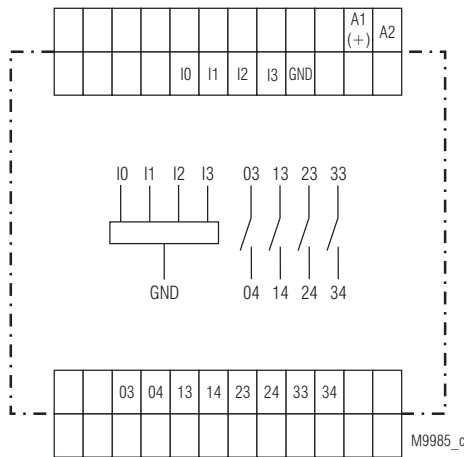

RP 5812S, RP 5812PS, RP 5812PC

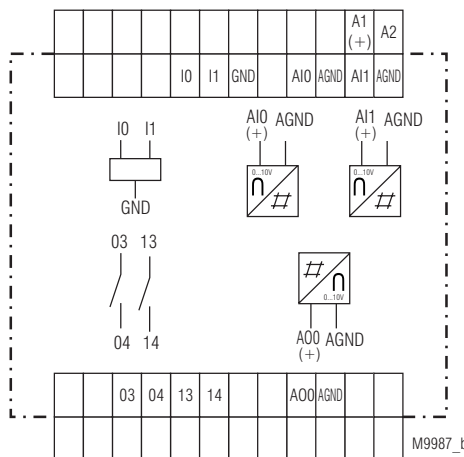

RP 5812S/001, RP 5812PS/001, RP 5812PC/001

Approvals and Markings



Application

- Remote monitoring control and operation of
 - Machinery and installations for industry and building automation.
 - Small power plants
 - Remote buildings
 - Unmanned production plants
 - Air-conditioning and refrigeration systems
 - Heating systems
 - Elevators and escalators
 - Alarm systems, burglar alarms
 - Smoke, fire and gas warning systems
 - Doors, gates and windows
 - Flood warning systems
- Level alarm in pumping stations
- Remote shut down of rental equipment when payment overdue
- Level monitoring in silos, tanks, etc.

Indication	
green LED „U _H “:	on when supply connected
yellow LED „GSM“ off:	SMS-Telecontrol module is off
flashes 600ms on / 600 ms off:	SMS-Telecontrol module searches for available network and logs on
flashes 75ms on / 3s off:	SMS-Telecontrol module is registered on GSM network.
on:	Data transmission in GSM network is taking place
yellow LED „Status“ off:	Configuration correct, SMS-Telecontrol module is working correctly
flashes:	Indication of failure code, see table “Fault indication by flashing code”
on:	SMS transmission take place

Settings

Safety remarks

- The SMS-Telecontrol module must not be used for safety relevant control functions due to signal availability.
- The use of the SMS-Telecontrol module in medical rooms must be evaluated thoroughly as medical equipment such as pacemakers etc may react to the radiofrequency of the SMS-Telecontrol module. Also be aware that the radio frequency of the SMS-Telecontrol module may disturb the function of insufficiently protected PCs, monitors and other electronic equipment.
- Delays in the transmission of I/O status may take place due to network problems.

General settings

- If the SMS-Telecontrol module is disconnected for a long period, (e.g. as when delivered) the battery must be charged. To do this the SMS-Telecontrol module needs to be connected to the supply Voltage for up to 6 h. Only after this time is correct operation is possible.

Attention

On delivery the battery is disconnected. Before the batteries can be charged the connection has to be made by changing the slide switch at the bottom edge of the unit to the ON position.

- On first activation a SIM card with a pin code of 1234 has to be inserted. This pin can then be changed by an SMS command. After pin change only the SIM card with the changed pin can to be used. If the pin number on the SIM card is different to the one in the configuration the SIM card may be locked when connecting to the GSM network. A locked SIM card can be unlocked by placing it in a mobile Phone and entering the PUK or Master pin.
- If the Reset/Default Konf. button on the front of the unit is pressed for 3-4 seconds while the unit is powered up, the SMS-Telecontrol module is reset. This means, that the any connection to an SMS network is disconnected and reconnected. If the reset button is pressed for more than 5 sec the configuration is reset to default and the unit makes a factory reset.
- Due to the internal battery back up, the function of the SMS-Telecontrol module is still available even if the power supply is disconnected for up to 24 hours.

Attention

It is your responsibility as an end user to dispose old batteries correctly. Of course, you may return replaced batteries to us.

Settings

Set up procedure of SMS-Telecontrol module

- Wire the i/p's- o/p's and the auxiliary supply connections
- Press the SIM eject button (use pen tip), insert the SIM-card with the Preconfigured pin 1234 into the SMS-Telecontrol module
- Power up the SMS-Telecontrol module
- Send the necessary configuration commands via text to the SMS-Telecontrol module (see manual)

Examples for configuration and communication of the SMS module via SMS:

Demand:

The SMS module located in the pump station, should be named “Pump station” and then answer with this name.

The following SMS is created and sent:

CFGDN\$Pump station#

Demand:

Input I0 shall send an SMS on the negative edge (turning off) of the input signal

The following SMS is created and sent:

DISEND\$0\$FE#

Demand:

Input I0 shall be named „ Pump“

The following SMS is created and sent:

DISYMB\$0\$Pump#

Demand:

The status „0“ of input I0 shall be named „ Pump stopped“

The following SMS is created and sent:

DITXTLO\$0\$Pump stopped#

An SMS is generated and sent by the SMS module caused by a defective Pump, it appears as follows:

Answer: „Pump station:Pump stopped“

Demand:

The current status of the (2 or 4) digital inputs can be called up.

The following SMS is created and sent:

?DIALL#

Answer: „Pump station:Pump stopped; Level to high“

and for the 2 analogue inputs:

and to call up the 2 analogue inputs if previously configured for level and motor temperature

?AIALL#

Answer: „Pump station: Level:180cm; pump temp: 85°C“

Safety notes

Attention:  It is important, that the connected voltage of the analogue inputs and the analogue outputs of the variant /001 are no larger than are specified in the Technical Data.

- The Li-Ion battery can not be changed by the user. Is there a need to replace the battery please send the device back to the manufacturer.
- Please note, before using, the other safety instructions of the manual INFOMASTER SMS-Telecontrol module RP 5812.

Technical Data

Input

Auxiliary Voltage A1-A2 (U_H): DC 24 V,

Nominal consumption A1-A2: max. 4.5 W at DC 24V

Inputs (digital)

RP 5812: 4 x i/p; I0 ... I3

DC 24 V with galvanic separation

RP 5812/001:

2 x i/p; I0 ... I1

DC 24 V with galvanic separation

Inputs (analogue)

RP 5812/001: 2 x i/p; AI0 ... AI1

DC 0 .. 10 V resolution 100 mV

Technical Data

Outputs

Contacts:

RP 5812: 4 N/O contacts
RP 5812/001: 2 N/O contacts

Thermal current I_{th} : 2A

Switching capacity to AC 15: IEC/EN 60947-5-1
3 A / AC 230 V (secondary voltage)

Electrical life

to AC15 at 1A / 230V: $\geq 1,5 \times 10^6$ switch. cycl. IEC/EN 60 947-5-1

Max. fuse rating: 4A gL IEC/EN 60947-5-1

Mechanical life: $\geq 30 \times 10^6$ switching cycles

Output (analogue)

RP 5812/001: AO0
DC 0..10V resolution 100 mV

GSM

Frequency band: 850 / 900 / 1800 / 1900 MHz
Power class: GSM 850 / 900 MHz: 4 (2 W)
GSM 1800 / 1900 MHz: 1 (1 W)
SIM-card: 1.8V and 3 V SIM cards are supported
Aerial jack: SMA (male)

General Data

Nominal operating mode: continuous operation

Temperature range: 0 ... + 40°C

Clearance and creepage distance:

Rated impulse Voltage / pollution degree: 4 kV / 2 IEC 60 664-1

EMC

Electrostatic discharge: 8 kV (air) IEC/EN 61 000-4-2

HF irradiation: 10 V / m IEC/EN 61 000-4-3

Fast transients: 2 kV IEC/EN 61 000-4-4

Surge

between wires for power supply: 1 kV IEC/EN 61 000-4-5

wire and ground: 2 kV IEC/EN 61 000-4-5

Interference suppression: Limit value class B EN 55011

Degree of protection:

Housing, Cover IP 30 IEC/EN 60 529

Terminals IP 20 IEC/EN 60 529

Housing:

thermoplastic with VO behaviour acc. to

UL subject 94

Vibration resistance:

Amplitude 0,35 mm

Frequency 10 ... 55 Hz IEC/EN 60 068-2-6

00 / 040 / 04 IEC/EN 60 068-1

Terminal designation:

EN 50 005

Wire connection:

DIN 46 228/-1/-2/-3/-4

fixed screw terminal (S): 0,2 ... 4 mm² solid or

0,2 ... 1,5 mm² stranded wire with sleeve

plug in screw terminal (PS): 0,1 .. 2,5 mm² solid or

0,1 .. 1,5 mm² stranded wire with sleeve

plug in cage clamp terminals (PC): 0,2 .. 2,5 mm² solid or

0,2 .. 1,5 mm² stranded wire with sleeve

Wire fixing:

fixed screw terminal (S),

plug in screw terminal (PS): Captive plus-minus-terminal screws M2,5

with self raising terminal box

plug in cage clamp terminals (PC): spring terminal for direct

plug in of wires,

screw driver 0,6 x 3,5 for

spring releasing

Mounting: DIN rail IEC/EN 60175

Weight: 216 g

Dimensions

Width x height x depth: 70 x 95 x 80 mm

Standard Types

RP 5812S DC 24 V

Article number: 0065147

• Auxiliary Voltage U_H : DC 24 V

• Inputs: 4 digital inputs DC 24 V

• Outputs: 4 relay outputs N/O contacts

• Width: 70 mm

RP 5812S/001 DC 24 V

Article number: 0065148

• Auxiliary voltage U_H : DC 24 V

• Inputs: 2 digital inputs DC 24 V

2 analogue inputs 0 ... 10 V

• Outputs: 2 relay outputs N/O contacts

1 analogue output 0 ... 10 V

• Width: 70 mm

Ordering Example

RP 5812 - - / 0 0 - AC/DC 19 ... 30 V

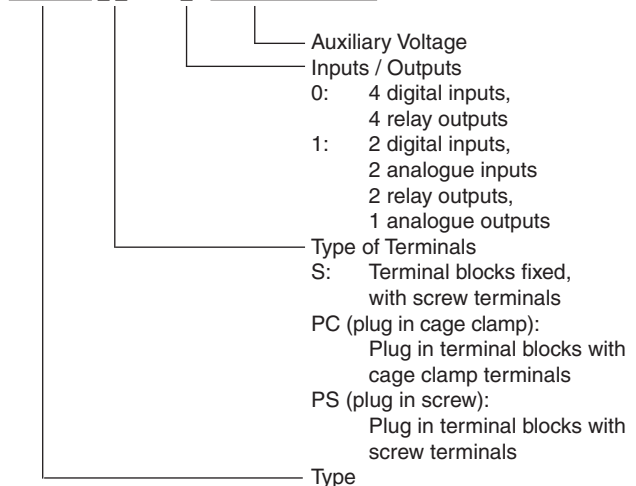

Accessories

OA 5810/900:	GSM-aerial, 90° angle Article number: 0062212
OA 5810/901:	GSM magnetic foot areal with 2,5 m connecting lead Article number: 0062213

Fault indicated by Flashing Code

The current state of the SMS-Telecontrol module is indicated by the flashing code on the status LED. The number of flashing pulses followed by a longer space relates to the failure code in the following table. After the longer space the flashing cycle is repeated until the state on the unit changes.

State LED	Description
OFF	No status for indication, normal operation
ON	SMS transmission
2 * flashes	Internal system failure, please contact the manufacturer
3 * flashes	Invalid configuration. When this failure occurs, the unit tries to reset the configuration to factory settings followed by a device test. If the failure remains, please contact manufacturer.
4 * flashes	No access on SIM-card Cause: no SIM-card inserted or invalid PIN for inserted SIM card
5 * flashes	No GSM network available Cause: insufficient radio signal, aerial placed in a poor location.
6 * flashes	In the configuration, the service centre for SMS transmission is not yet defined. Cause: The CFGINT command sequence SMS has not been sent to the module
7 * flashes	No administrator for using are defined. No user administrator is defined Cause: The CFGINT command sequence SMS has not been sent to the module

LEDs for each I/O on the front of the unit indicate the status of the in- and outputs.