

#### Your Advantages

- Quick correction of insulation faults in complex power networks
- Universal auxiliary voltage range
- Easy operation

#### Features

- Insulation troubleshooting in AC, DC and AC/DC networks (IT systems) in connection with the locating current injector RR 5886 according to DIN EN 61557-9 (VDE 0413-9):2009 and DIN EN 61557-1 (VDE 0413-1)
- Insulation coordination according to IEC 60664-1
- Connection of max. 4 or 8 current transformers depending on the design
- RS-485 bus connection to synchronise the test current analysis and optionally for the connection to the Modbus RTU field bus
- Status output of insulation fault detection via external switching output
- Memory characteristics adjustable via bridge X1-X2
- Collective signalling relay to output preliminary warning and alarm states
- Pushbutton for manual reset of alarm states as well as testing of current transformers and their calibration
- Terminal connection for the storage of alarm states
- Width: 105 mm

#### Product Description

The locating current injector RR 5886 in connection with the insulation fault locator RR 5887 monitors and localises insulation faults in complex AC/DC networks (IT systems). The external current transformers work independently of each other. They are simply connected to the measuring channels of the insulation fault locator RR 5887 and are calibrated by it.

The number of measuring channels is increased by combining several insulation fault locators via a RS-485 connection. The search for insulation faults in extensive networks can be refined in this manner. Two different alarm levels facilitate the timely detection of a dangerous insulation state. The devices are operated easily and intuitively thanks to automatic balancing and a clear layout of the setting elements. The early detection and localisation of insulation faults permits their quick and targeted correction. As user you will benefit from the operating reliability and high availability of your system.

#### Approvals and Markings



#### Applications

- Insulation fault detection in complex AC/DC networks
- Industry, shipbuilding, plant engineering, PV systems
- Quick fault correction of insulation faults in medical facilities

#### Function Diagram

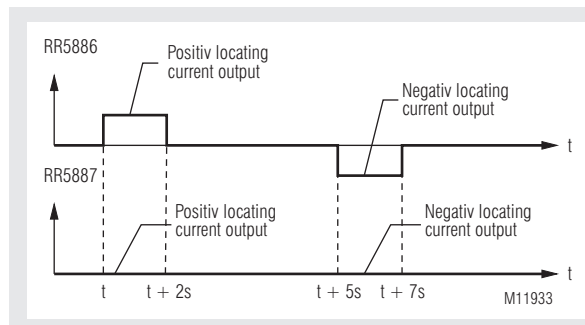

#### Circuit Diagram

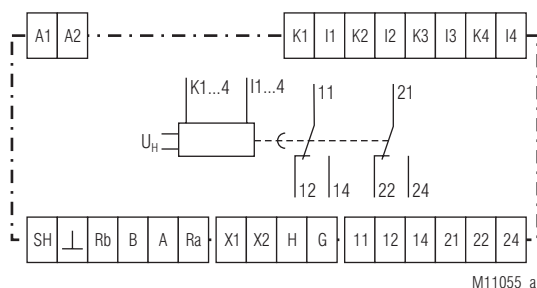

#### Indication

- Green LED "ON": On, when supply connected
- Yellow LED Kanal 1..4: Pre-warning: Display of an insulation fault current > 1 mA in the corresponding channel
- Red LED Kanal 1..4: Alarm: Display of an insulation fault current > 5 mA in the corresponding channel
- Yellow LED „BUS“: Indicates RS-485 bus activity

#### Connection Terminals



Terminal designation	Signal description
A1(+), A2	Auxiliary voltage AC or DC
K1..K4/ I1..I4	Current transformer measur. channel
SH, GND, Rb, B, A, Ra	RS-485 Bus (galvanic separation)
X1, X2	Switching input Alarm storage
G, H	Status switching output Insulation fault detection
11, 12, 14	Indicator relay prewarning (changeover contact)
21, 22, 24	Indicator relay alarm (changeover contact)



**Switching input**

The device is equipped with a switching input (terminals X1, X2), which can be furnished either with a simple wire bridge or selected actively as digital control input from an external device with max. 24 V DC.

The input is low-active, i. e. when applying a low-level, the function "ALARM MEMORY" is active, otherwise it is inactive.

If the function is active, no prewarning/alarm states are reset following an insulation fault locating cycle. A reset takes place only after pushing the "Alarm reset / Test / Transformer calibration" button for at least 3 sec. Only the prewarning / alarm states are stored. The residual current values transmitted via Modbus are always up-to-date.

X1  *ALARM MEMORY active*  
 X2  - Alarm states are preserved  
 - Manually resettable via pushbutton

X1  *ALARM MEMORY inactive*  
 X2  - Alarm states are updated after each measuring cycle

**Switching output**

The device is equipped with a transistor switching output (terminals G, H), which is protected by a series-connected PTC (RN = 220 Ω).

In the idle state (no insulation fault detection active), the output is high-resistance. During insulation fault detection, the output is low-resistance (RN) and delivers a low-level in conjunction with a series pull-up resistor and an external voltage source.

**RS-485 bus connection**

The insulation fault locator RR 5887 generally works in slave mode. It synchronises itself independently with the test current output by monitoring the RS485 telegram. All connected insulation fault locators RR 5887 work in parallel and independently from each other.

If the insulation fault location system is part of a Modbus RTU field bus system for every device a free bus address has to be selected via a 10-step rotary switch. In case of need a Modbus Master can read out insulation fault current values from the connected devices with a resolution of 0,5 mA.

If there is no external bus connection, the bus address has no special meaning and the position of the rotary switch is arbitrary. The rotary switches for baudrate selection of all RR 5886 and RR 5887 devices have to be identical independent of the bus operation mode. The preferred baudrate is 9600 Baud (rotary switch position 4).

**Influence of discharge capacities**

The insulation fault locator is also able to perform reliable measurements under the influence of discharge capacities up to a certain size. The influence of discharge capacities depends on the insulation resistance and the mains voltage. Reliable detection of insulation resistance is ensured up to a discharge capacity of 1 µF.

The lower the mains voltage, the greater the permissible discharge capacity may be. For example, with mains voltages of 50 V, 20µF and more can also be processed without problem.

Insulation fault detection is no longer possible if the influence of the discharge capacities becomes too great. The measuring result may become poorer, in addition, when the discharge capacities are distributed unevenly in the network.

However, the symmetry relationships of the insulation fault resistances themselves do not affect the quality of the measurement.

**Attention:**

If insulation faults are present between several conductors and PE, mains compensation currents flow through the insulation fault resistances overlaying the actual insulation fault currents. The measured insulation fault current can be reduced by half here in the extreme case.

If several insulation faults occur simultaneously in a network, the test current is divided among the individual fault branches. Depending on the fault resistance, it may happen that the maximum test current is not sufficient to address all detectors. To prevent such insulation faults from remaining undetected, it is recommended to position a current transformer in the main branch of the monitored network, which reliably detects the overall insulation fault (see connection diagram).

**Common operation of insulation monitor and insulation fault location system**

Insulation monitoring and insulation fault location are often used in addition (s. connection example). As a rule, an insulation monitor detects an insulation fault and then controls an insulation fault location system that locates the fault. During localization, the insulation monitor should temporarily stop his monitoring activity in order to avoid mutual interference between the insulation monitoring device and the localization system.

**Current transformer calibration**

Current transformer calibration is performed after switching on the device or after pushing the "Alarm reset / Test / Transformer calibration" pushbutton to compensate tolerances of the magnetic material of the current transformers and the resulting differences of the magnetic amplification.

**Insulation fault measurement in AC/DC networks**

If an alternating current network, containing a downstream rectifier, is monitored, insulation fault detection can also be performed in the direct voltage circuit if the discharge capacities in this circuit are not too high. Because fault detection can be performed simultaneously in two different network forms – alternating current network and direct current network – the indications displayed for prewarning and alarm are quantitatively valid only for the network form set with the rotary switch. The network form not set will deliver results deviating by the factor 2. However, they can still be analysed in terms of their tendency, i. e. a potential insulation fault is still indicate.

**Insulation fault current display**

The locating current injector takes the power for the test current from the monitored network itself. Insulation fault current measurements are nearly identical both for AC and DC networks. However, a difference in the level of the test current is obtained through the network form itself. With AC networks, the test current is only half the value as with DC networks. With 3AC networks, the factor is 0.67. These differences are taken into account when determining the level of the insulation fault current and with the display of the alarm values.

## Modbus RTU

For communication between motor controller and a supervising control the Modbus RTU protocol according to Specification V 1.1b3 is used.

### Address- / Baud rate setting

Pos. Potentiom. ADR 10x	0	1	2	3	4	5	6	7	8	9
Address Modbus RTU	100	101	102	103	104	105	106	107	108	109

Pos. Potentiom. BAUD	1	2	3	4	5	6	7	8
Baud rate Baud	1200	2400	4800	9600	19200	38400	57600	115200

The device address and baudrate are only read once after application of the auxiliary voltage.

### Bus Interface

Protocol	Modbus Seriell RTU
Address	100 bis 109
Baud rate	1200, 2400, 4800, 9600, 19200, 38400, 57600, 115200 Baud
Data bit	8
Stop bit	2
Parity	None

More information about the interface, wiring rules, device identification and communication monitoring can be found in the Modbus user manual.

### Function-Codes

At RR 5887 the following function codes are implemented:

Function-Code	Name	Description
0x04	Read Input Register	Device state / read current transformer state and insulation fault currents

## Indication of alarm and functional states

### Indication of alarm states

The display of an alarm state as well as the response of the corresponding common alarm signalling relay act at least for the duration of a measuring cycle (12 sec). The alarm state is cancelled again when the respective threshold of the insulation fault current, under consideration of a defined hysteresis, is fallen below again.

The switching terminal "ALARM MEMORY" must be equipped if the alarm state shall persist permanently.

The response threshold for the insulation fault current does not depend on the network form chosen.

### Prewarning

<b>Response threshold:</b>	1 mA
<b>Indication:</b>	Yellow LED continuously on
<b>Common alarm relay:</b>	Collective signalling relay "Prewarning" responds
<b>Hysteresis for return:</b>	0.1 mA
<b>Duration of the alarm state:</b>	Until response threshold if fallen below

### Alarm

<b>Response threshold:</b>	5 mA
<b>Indication:</b>	Red LED continuously on
<b>Common alarm relay:</b>	Collective signalling relay "Alarm" responds
<b>Hysteresis for return:</b>	0.5 mA
<b>Duration of the alarm state:</b>	Until response threshold if fallen below

### No insulation faults present

<b>Indication:</b>	The yellow LED briefly (200 ms) lights after the measuring cycle has been completed
--------------------	---

### Display of current transformer faults

The insulation fault locator does not feature any control elements for setting the completion of current transformers. For this reason, the device must detect the presence of transformers independently. This happens together with the transformer calibration after switching on the device or after pushing the "Alarm Rest/ Test/ Transformer calibration" button.

The device can detect both, a transformer short circuit and a broken supply line (open transformer contact) individually for each channel.

The check for transformer faults is cyclically repeated after an insulation fault measurement has been completed allowing a transformer fault to be detected also under ongoing operation.

### Short circuit at current transformer

<b>Indication:</b>	Red LED flashes
<b>Duration of indication:</b>	Until the short circuit is resolved

### Indication detected/interrupted current transformer

<b>Indication:</b>	Yellow LED flashes
<b>Duration of indication:</b>	Until current transformer test is completed or open current transformer connection is closed again

### Indication of invalid insulation fault measurements

If the value determined for the insulation fault current is invalid, e.g. because of excessive discharge capacities, or the direction of line routing through the current transformer is wrong, this condition is also indicated.

<b>Indication:</b>	Yellow LED flashes
<b>Duration of indication:</b>	Until a valid measured value is determined again or the line direction through the transformer was turned around

**Indication of alarm- and function states****Summary: Indication of alarm- and function states**

Operation	State of transducer	Insulation failure current I <sub>fs</sub>	Indication
Measuring operation	Transducer connection ok	Prewarning: I <sub>fs</sub> > 1 mA	Yellow LED continuously on
		Alarm: I <sub>fs</sub> > 5 mA	Red LED continuously on
		No Insulation failure: I <sub>fs</sub> < 1 mA	Yellow LED Briefly lights at the end of the measuring cycle
		Measurement value invalid	Yellow LED flashes
	Short circuit at transducer		Red LED flashes
Transducer Test / calibration	Breaking at transducer		Yellow LED flashes
	Transducer not connected		No indication
	Transducer short circuit		Red LED flashes
	Transducer detected		Yellow LED flashes

**Technical Data****Auxiliary voltage**

**Measured nominal voltage U<sub>B</sub>:** AC/DC 24 ... 80 V;  
AC/DC 85 ... 230 V  
**Operating voltage U<sub>e</sub>:** AC/DC 21 ... 88 V;  
AC 77 ... 265 V, DC 77 ... 290 V  
**Frequency range:** DC or AC 45 ... 400 Hz  
**Nominal consumption:** DC max. 3 W  
AC max. 3.5 VA

**Monitored network**

**Operating voltage U<sub>B</sub>:** DC / AC / 3AC 21 ... 500 V  
**Measured nominal voltage U<sub>e</sub>:** DC / AC / 3AC 24 ... 455 V  
**Frequency range:** AC / 3AC 40 ... 60 Hz  
**Rated current range for insulation test currents:** 1 ... 5 mA  
**Maximum test current output:** 6.5 mA  
**Response sensitivity:** 0.4 mA  
**Response time:** 15 s  
**Measuring accuracy:** ± 10 %  
**Bus**  
(galvanic separation): RS-485

**Current transformer**

**Terminals:** K1, I1 ... K4, I4  
**Residual Current Transformer:** ND 5017  
**Burden:** 180 Ω  
**Rated voltage:** 500 V  
**Rated frequency:** 40 ... 60 Hz  
**Response sensitivity:** 0.2 mA  
**Measuring range:** 0.5 ... 10 mA  
**Number of measuring channel:** 4

**Switching input**

**Terminals:** X1, X2  
**Configuration (passive)**  
**Low-level:** Bridge set / input low resistance  
**High-level:** Input open / input high-resistance  
**Configuration (active)**  
**Voltage range (low/high):** 0 V / 12 ... 24 V  
**Max. switching current (24 V):** 0.5 mA

**Switching output**

**Terminals:** H(+), G(-)  
**Switching output (passive):** Transistor outputs  
**Insulat. fault detection active:** Output low resistance (minimal 220 Ω via PTC)  
**Insulat. fault detection inactive:** Output high resistance  
**Switching voltage max.:** 24 V  
**Switching current max. (24 V):** 10 mA

**RS-485 Bus**

**Terminals:** SH, L, Rb, B, A, Ra  
**Bus:** Galvanic separation  
**Transmission medium:** Twisted, shielded two-wire line (SH)  
**Network termination:** Bus termination via bridges Rb, B and Ra, A

## Technical Data

### Connection alarm signalling relay

<b>Output:</b>	2 changeover contacts	
<b>Contact material:</b>	AgNi + 0.3 µm Au	
<b>Measured nominal voltage:</b>	AC/DC 24 ... 240 V	
<b>Limiting continuous current (I<sub>th</sub> max):</b>	2 x 5 A	
<b>Switching capacity</b> to AC 15		
NO contact:	3 A / AC 230V	IEC/EN 60947-5-1
NC contact:	1 A / AC 230V	IEC/EN 60947-5-1
<b>Elektrical life</b> to AC 15		
At 3 A, AC 230V:	2 x 10 <sup>5</sup> switching cycl.	IEC/EN 60947-5-1
<b>Short circuit strength</b> <b>max. fuse rating:</b>	6 A gG / gL	IEC/EN 60947-5-1
<b>Mechanical life:</b>	> 20 x 10 <sup>6</sup> switching cycles	

### Terminal designation relay:

Prewarning:

Alarm:

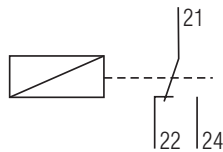
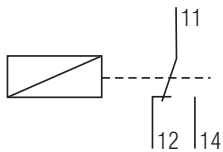

M11062

## General Data

<b>Nominal operating mode:</b>	Continuous operation	
<b>Temperature range:</b>		
Operation:	- 20 ... + 60 °C	
Storage:	- 25 ... + 60 °C	
Relative air humidity:	93 % at 40 °C	
<b>Altitude:</b>	≤ 2000 m	
<b>Clearance and creepage distance</b>		
Rated impulse voltage / pollution degree:	4 kV / 2	IEC 60664-1
<b>EMC</b>		
Electro static discharge (ESD):	8 kV (air)	IEC/EN 61000-4-2
HF irradiation		
80 MHz ... 2.7 GHz:	10 V / m	IEC/EN 61000-4-3
Fast transients:	2 kV	IEC/EN 61000-4-4
Surge voltage between		
wires for power supply:	2 kV	IEC/EN 61000-4-5
Between wire and ground:	4 kV	IEC/EN 61000-4-5
HF-wire guided:	10 V	IEC/EN 61000-4-6
Interference suppression:	Limit value class B	EN 55011
<b>Degree of protection</b>		
Housing:	IP 40	IEC/EN 60529
Terminals:	IP 20	IEC/EN 60529
Housing:	Thermoplastic with VO behaviour acc. to UL subject 94	
<b>Vibration resistance:</b>	Amplitude 0.35 mm Frequenz 10 ... 55 Hz, IEC/EN 60068-2-6 20 / 060 / 04	
<b>Climate resistance:</b>		
<b>Terminal designation:</b>	EN 50005	
<b>Wire connection</b>	DIN 46228-1/-2/-3/-4	
<b>Fixed screw terminals</b>		
Cross section:	0.2 ... 1.5 mm <sup>2</sup> (AWG 24 - 16) solid or 0.2 ... 1.5 mm <sup>2</sup> (AWG 24 - 16) stranded wire with ferrules	
Stripping length:	7 mm	
<b>Fixing torque:</b>	0.4 Nm	
<b>Mounting:</b>	DIN-rail IEC/EN 60715	
<b>Weight:</b>	Approx. 225 g	

## Dimensions

Width x height x depth: 105 x 90 x 71 mm

## Standard Type

RR 5887.12 AC/DC 85 ... 265 V		
Article number:	0068221	
• Auxiliary voltage:	AC/DC 85 ... 230 V	
• Rated current for insul. test:	5 mA	
• Maximum test current output:	6.5 mA	
• Response sensitivity:	0.4 mA	
• Prewarning (Hysteresis: 0.1 mA):	1.0 mA	
• Alarm (Hysteresis: 0.5 mA):	5.0 mA	
• Width:	105 mm	

## Variant

RR 5887.12/010 AC/DC 85 ... 265 V		
Article number:	0067691	
• Auxiliary voltage:	AC/DC 85 ... 230 V	
• Rated current for insul. test:	1.0 mA	
• Maximum test current output:	1.0 mA	
• Response sensitivity:	0.3 mA	
• Prewarning (Hysteresis: 0.1 mA):	0.5 mA	
• Alarm (Hysteresis: 0.1 mA):	1.0 mA	
• Width:	105 mm	

## Ordering example

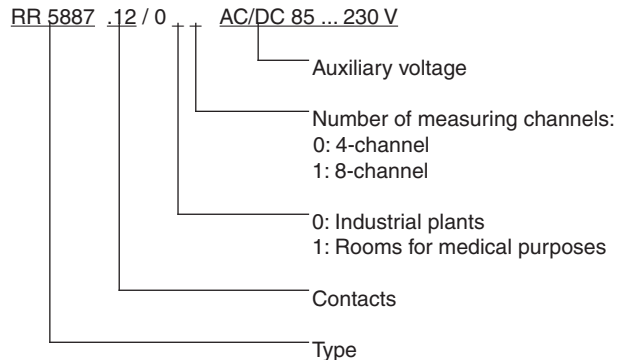

## Parameter table

Every slave owns an output- configuration- and actual value table. In these tables it is defined under which address the parameters can be found.

Input Register (Device state / prozes data):

Register-Adress	Protocol-Adresse	Name	Value range	Description	Data type	Access rights
30001	0	State Insulation fault detection	0 ... 1	0: Insulation fault detect. inactive 1: Insulation fault detect. done / insulation fault currents valid	UINT16	Read
30002	1	No. of channels	4 ... 8	0x0004: 4-channel variant 0x0008: 8-channel variant	UINT16	Read
30003	2	Max. insulation fault	1 ... 5	Max. insul. fault in mA	UINT16	Read
30004	3	Network form	0 ... 2	0x0000: DC 0x0001: AC 0x0002: 3AC	UINT16	Read
30005 ... 30008	0x0004 ... 0x0007	State Current transformer 1 ... 4	0x0000 ... 0x20FF	MSB: 0x00: Transformer not connected 0x01: Transformer connected 0x02: Prewarning 0x04: Alarm 0x10: Short circuit 0x20: State of transform. unknown/faulty LSB: Insul. fault current x 0.1 mA (0xFF: Invalid meas. value)	UINT16	Read
30009 ... 30012	0x0008 ... 0x000B	State Current transformer 5 ... 8	0x0000 ... 0x20FF	MSB: 0x00: Transformer not connected 0x01: Transformer connected 0x02: Prewarning 0x04: Alarm 0x10: Short circuit 0x20: State of transform. unknown/faulty LSB: Insul. fault current x 0.1 mA (0xFF: Invalid meas. value)	UINT16	Read
30013	0x000C	Alarm memory	0x0000 ... 0xFFFF	MSB: Bit 7 ... 0 *) Alarm occurred in current transformer 8 ... 1 LSB: Bit 7 ... 0 prewarning occurred in current transformer 8 ... 1	UINT16	Read

\*) The stored alarm states remain until reset by the alarm push button.

## Sequence Diagram Modbus Control Insulation Fault Location

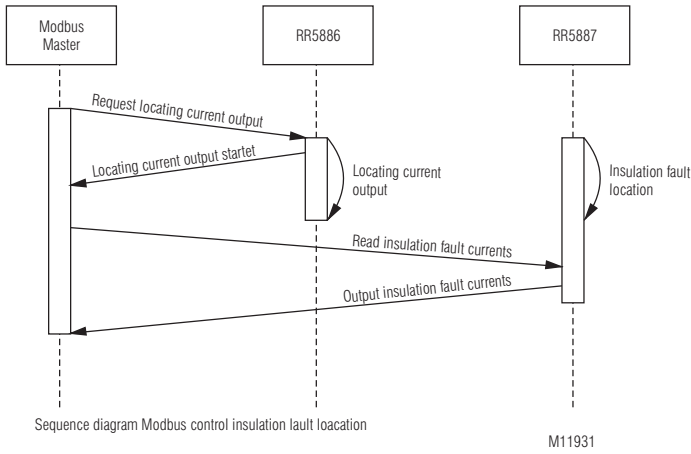

## Modbus Control Insulation Fault Detection Telegram Examples

Request test current output:  
 6Xh, 02h, 00h, 00h, 00h, 01h, XXh, XXh

Read insulation fault currents: (4-channel):  
 6Xh, 04h, 00h, 04h, 00h, 04h, XXh, XXh

Read insulation fault currents: (8-channel):  
 6Xh, 04h, 00h, 04h, 00h, 08h, XXh, XXh

## Connection to measuring bus /Profibus gateway

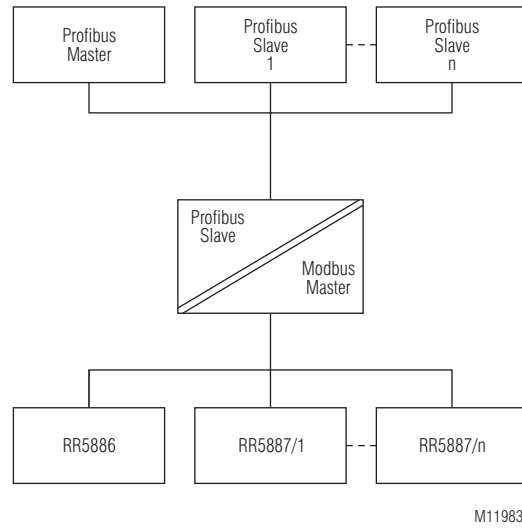

## System overview

### Insulation fault without external Modbus-Master (stand-alone system)

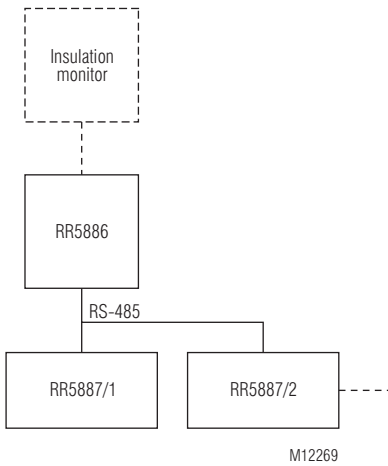

### Insulation fault with external Modbus-Master

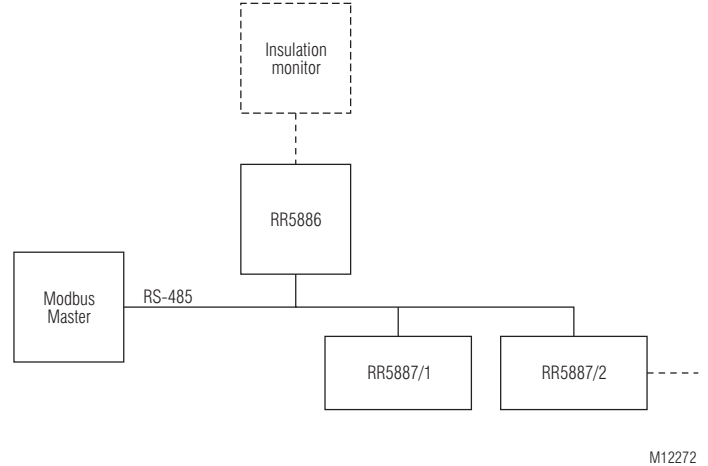

#### Example for Modbus setting:

Device	Adress-Potentiometer	Potentiometer position	Modbus Adress
RR 5886	ADR 101 – 109	Master	-
RR 5887/1	ADR 100 – 109	0 (optional)	-
RR 5887/2	ADR 100 – 109	0 (optional)	-
...	ADR 100 – 109	0 (optional)	-

#### Example for Modbus setting:

Device	Adress-Potentiometer	Potentiometer position	Modbus Adress
RR 5886	ADR 101 – 109	1	101
RR 5887/1	ADR 100 – 109	0	100
RR 5887/2	ADR 100 – 109	2	102
...	ADR 100 – 109	...	...

- Insulation fault detection in AC / DC / 3AC IT networks in connection with the locating current injector RR 5886
- External selection via an insulation monitoring device possible

**Residual Current Transformer ND 5017/024**

- The Residual Current Transformer ND 5017/024 is designed for DIN rail mounting or screw-type mounting
- Mounting on the top-hat rail may be done horizontally or vertically

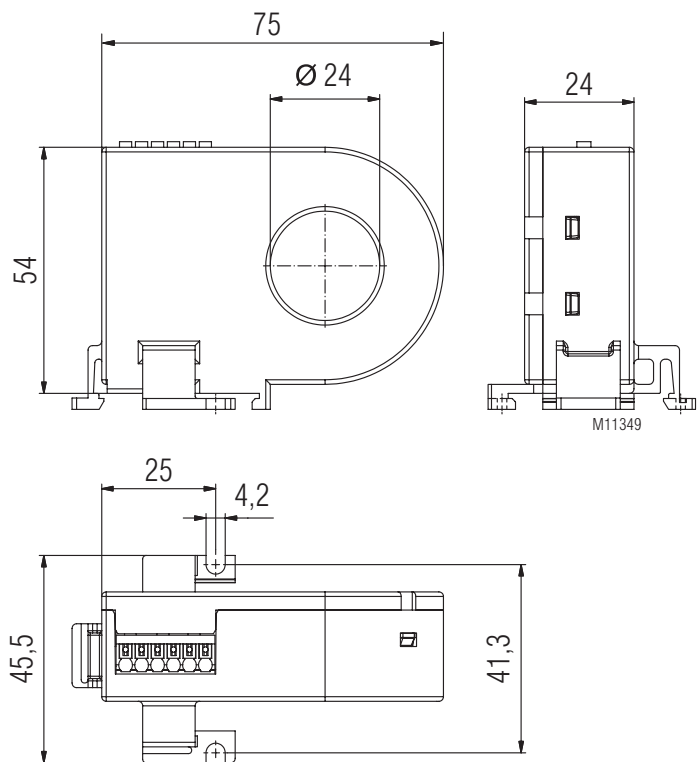

**Residual Current Transformer ND 5017/070 (on request)**

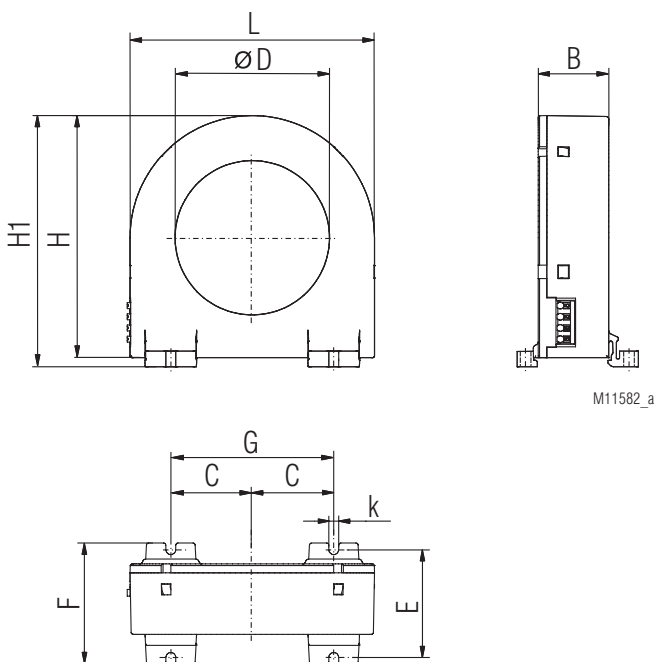

**Technical Data**

<b>Rated voltage:</b>	500 V
<b>Rated nominal voltage:</b>	1 A
<b>Rated transformation ratio:</b>	1 : 3000
<b>Burden:</b>	180 Ω
<b>Temperature range:</b>	- 20 ... + 60 °C
<b>Rated impulse voltage / pollution degree:</b>	4 kV / 3
<b>Housing:</b>	Thermoplastic with VO behaviour acc. to UL subject 94
<b>Vibration resistance:</b>	Amplitude 0.35 mm frequency 10 ... 55 Hz, IEC/EN 60068-2-6 20 / 060 / 04
<b>Climate resistance:</b>	
<b>Wire connection</b>	
Single wire	Up to 1 m
≥ 0.75 mm <sup>2</sup> :	Up to 10 m
≥ 0.75 mm <sup>2</sup> twisted:	Up to 25 m
Cable shield ≥ 0.5 mm <sup>2</sup> :	Up to 25 m (Shield on one side on I-conductor and not to be earthed)
<b>DIN rail mounting:</b>	Integrated clips for vertical and horizontal mounting
<b>Screw fixing:</b>	M3 or M4
<b>Fixing torque:</b>	Max. 0.8 Nm
<b>Weight:</b>	97 g

For DIN rail mounting or screw mounting

ND 5017/070	∅D	L	H	H1	B	C	F	k	E	G
Dimensions/mm	70	111	110	115	32	37	55	4,2	50*	74*
Weight / g	Approx. 315									

\*) Drill tolerance for screw mounting: ± 0.5 mm

**Mounting instructions for screw mounting**

High forces when mounting may damage the current transformer fixtures. The fixing clips are designed to support the current transformer. Forces that are applied by the cable running through the current transformer can only be tolerated within limitations. During installation and afterwards please make sure that the wires are led through the current transformer without applying pressure and remain stable in that position.



## Residual Current Transformer ND 5017/120



The listed current transformers are only approved for operation with this unit.

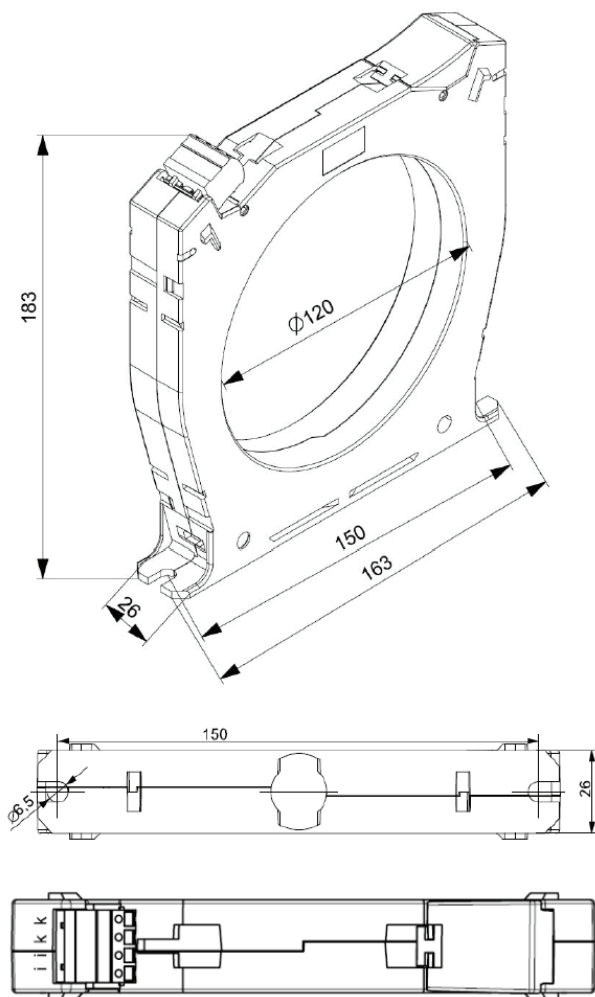

### Technical Data

**Ambient temperature:** - 40 ... + 80 °C / 233 K ... 353 K  
**Inflammability class:** V0 according to UL94

#### Insulation coordination according to IEC 61869-1

Highest rated operating voltage  $U_m$ : AC 720 V  
 Rated impulse voltage: 3 kV  
 Rated impuls voltage / pollution degree: 8 kV / 3

**Rated transformation ratio:** 3000 / 1  
 Rated primary current: 1 A  
 Burden: 200 ... 220  $\Omega$   
 Inductance: 310 H

#### Wire connection

Wire cross section: 0.2 ... 2.5 mm<sup>2</sup> rigid /  
 0.2 ... 2.5 mm<sup>2</sup> flexible / AWG 24 ... 12  
 Single wires: Up to 1 m  
 Single wires twisted: Up to 10 m  
 Shield cable  $\geq 0.5$  mm<sup>2</sup>: Up to 25 m  
 (Shield connected to I-conductor on one side and not grounded)  
 Stripping length: 6 mm  
 Wire fixing: Terminals with spring connection and  
 direct (Push in) technology  
 Actuating force: 40 N max.

#### Mounting

DIN rail mounting: Vertical and horizontal mounting  
 on enclosed socket  
 ND 5017/120: Screw fastening also possible  
 Weight: Approx. 570 g

## Connection Example

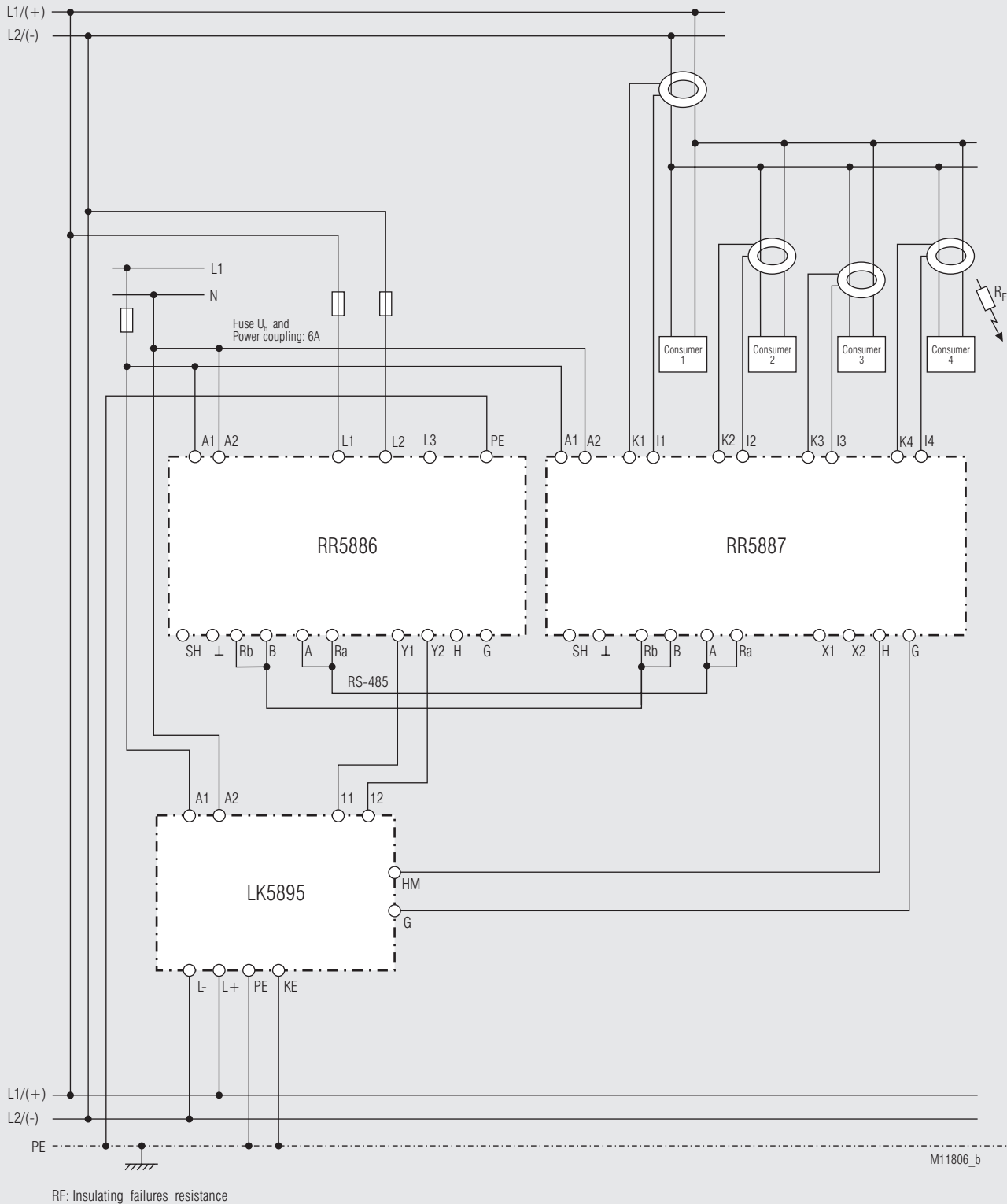

Insulation monitoring and insulation fault detection with 4 connected current transformers in a AC (DC) - network with subdistribution - insulation fault detection can be controlled by the insulation monitor /LK 5895; bus termination of the first and last device on the RS-485 bus.

## Connection Example

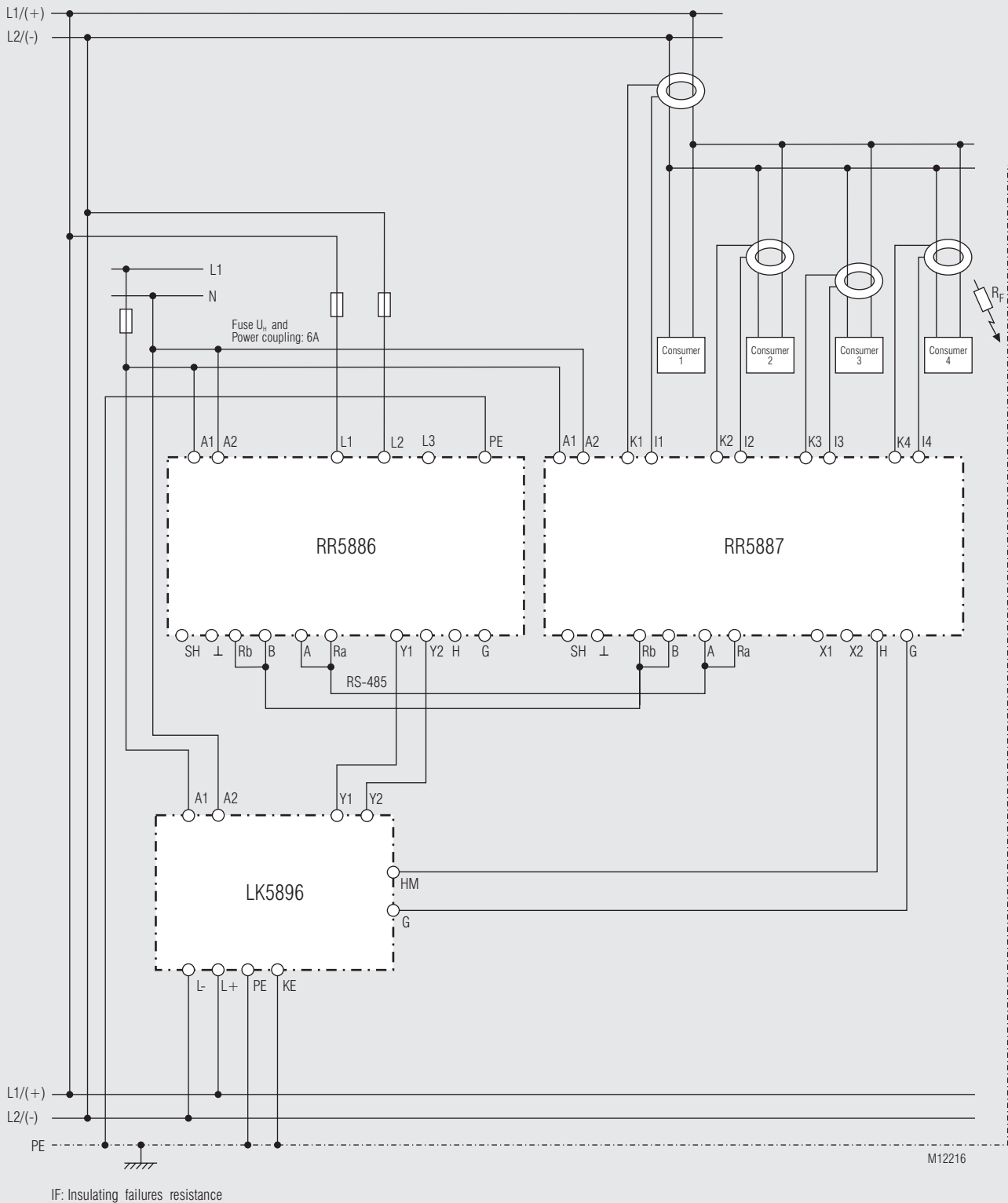

Insulation monitoring and insulation fault detection with 4 connected current transformers in a AC (DC) - network with subdistribution - insulation fault detection can be controlled by the insulation monitor /LK 5896); bus termination of the first and last device on the RS-485 bus.

## Connection Example

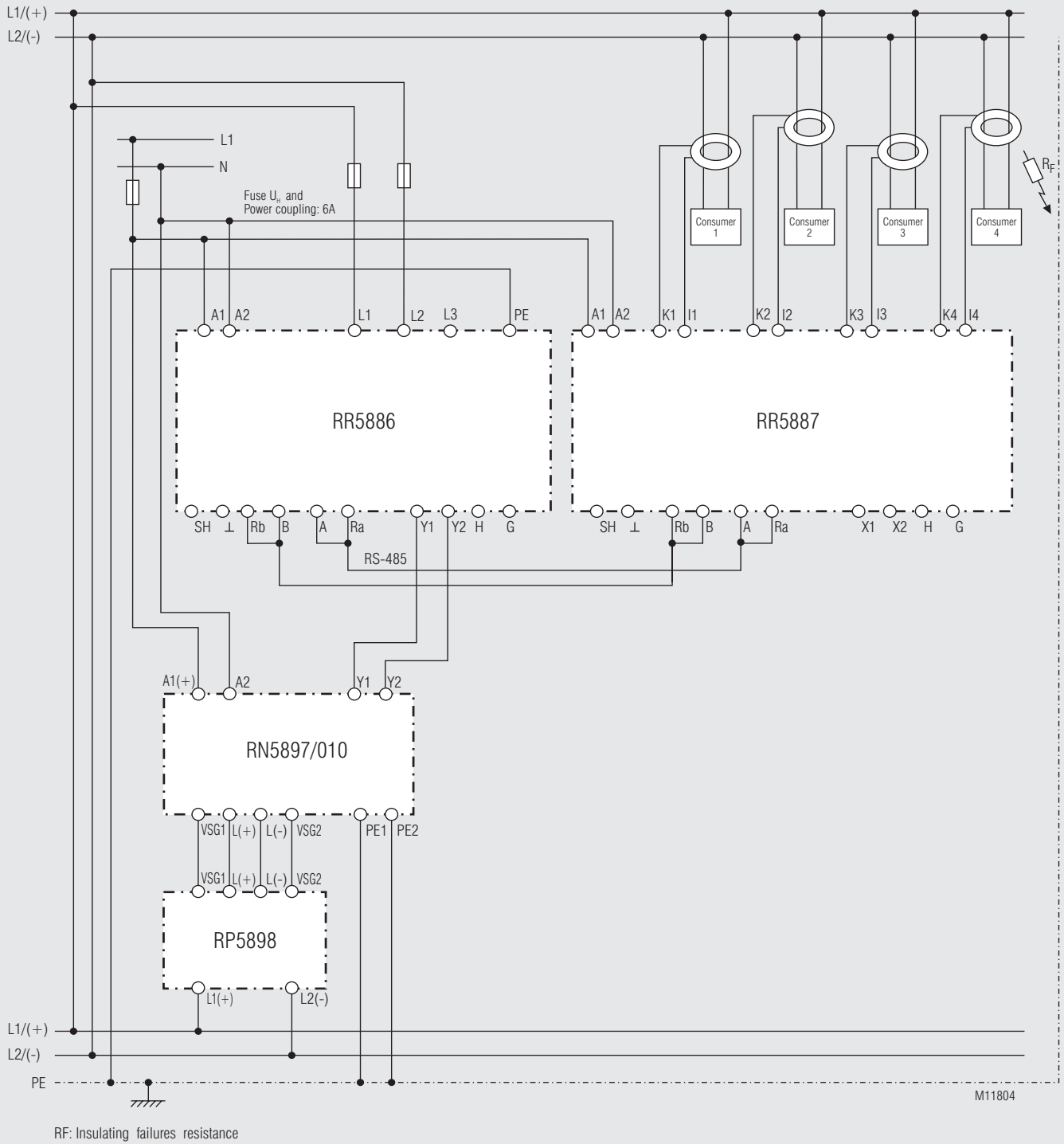

Insulation monitoring and insulation fault detection with 4 connected current transformers in a DC/AC network with subdistribution - insulation fault detection can be controlled by the insulation monitor (RN 5897/010); bus termination of the first and last device on the RS-485 bus.

## Connection Example

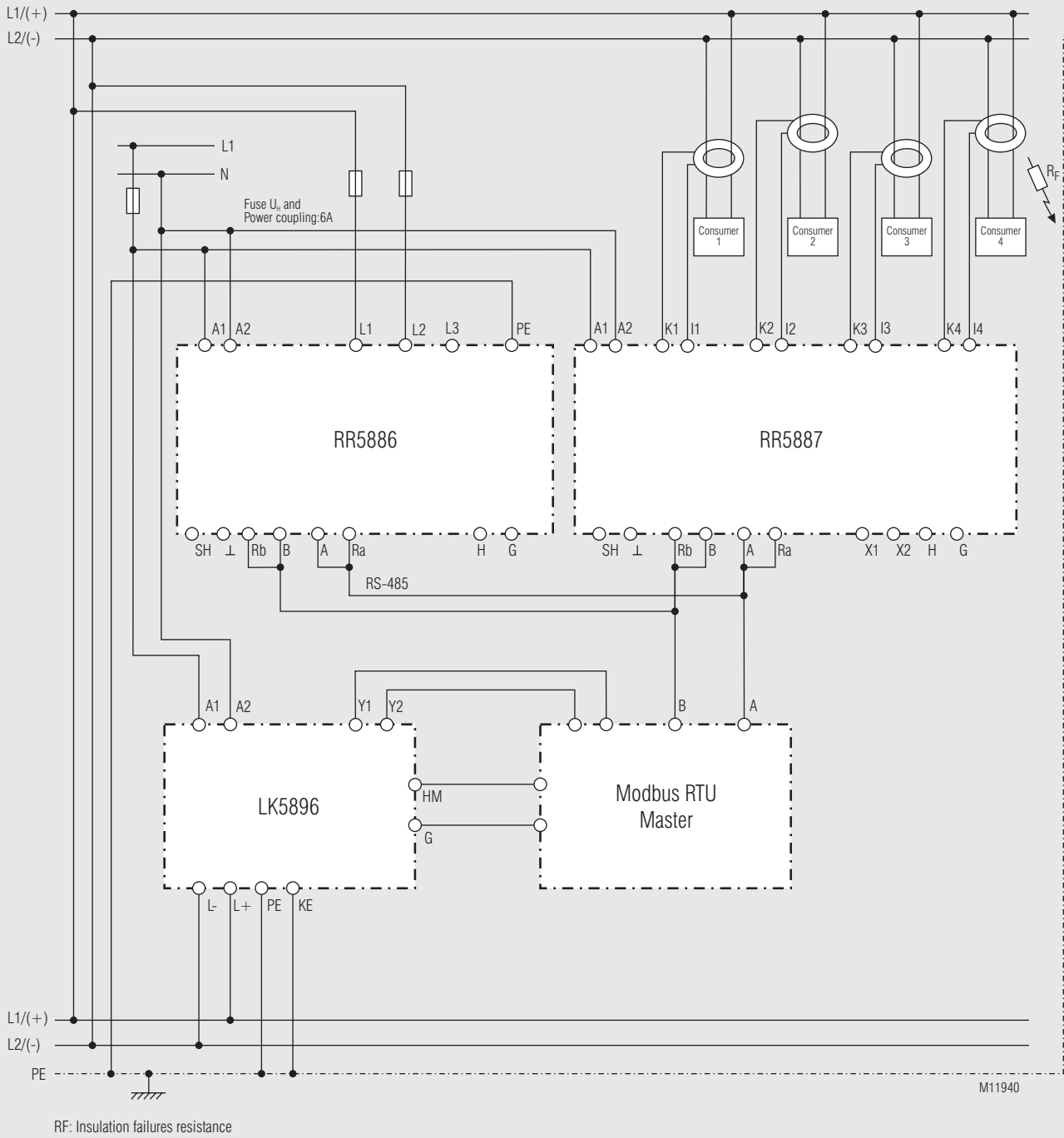

Modbus control insulation fault detection with external bus master

