



Actuator 165EBK001

Actuator for the safety sensors of the eloProtectE 165ESK... series. The actuator is suitable for the easily coded and individually programmable safety sensors. No additional actuator required for one-off coding – this is included with the sensor.

With safety sensor 165 ESK 00. 3. the actuator is programmed on the sensor. After this process has been completed, the sensor detects only the programmed actuator.

Technical specifications

- Flexibility in installation and use from variable actuation direction
- Hole dimensions compatible with actuators for magnetically actuated safety sensors
- Screw covers prevent easy removal and the accumulation of dirt
- Strong resistance against cleaning agents (ECOLAB) makes this suitable for use in the food and packaging industries.

Technical drawing

IMAGE 1/1

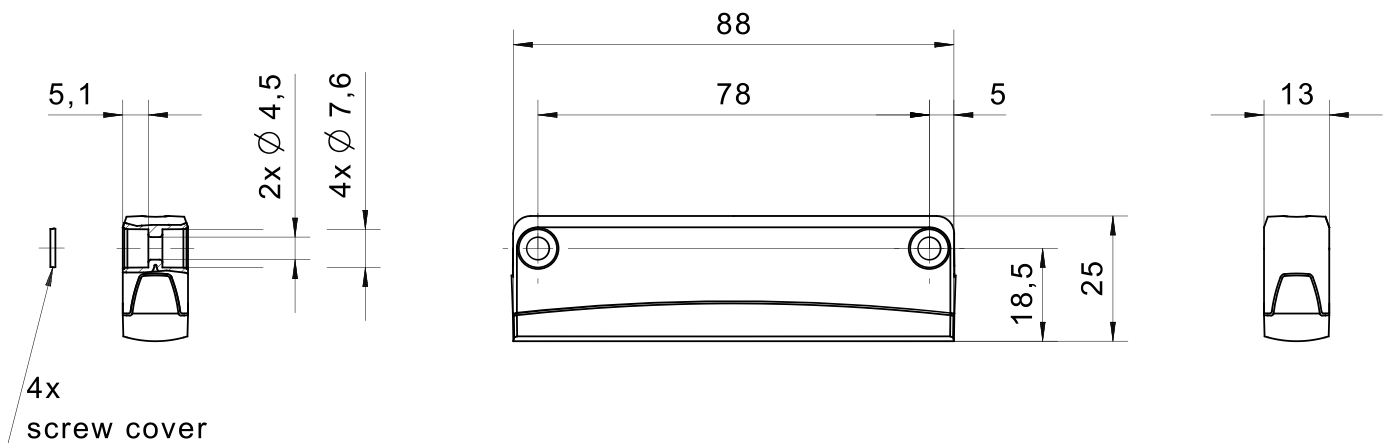

With safety sensor 165 ESK 00. 3. the actuator is programmed on the sensor. After this process has been completed, the sensor detects only the programmed actuator.

Article characteristics

Attribute	165EBK001
Weight	20 g
Coding acc. to EN ISO 14119	High
Suitable for sensor type(s)	165ESK00.1. / 165ESK00.3.
Dimensions	88x25x13
Housing material	PBT/PC
Housing colour	grau/schwarz
Mounting type	screwed
Torque for fastening screws	0.7 N m