



## Actuator 165MBK

When used with the corresponding safety sensor, the magnetic actuator of the new eloProtect M range enables optimised operating distances and offset values as well as increased tampering protection.

### Technical specifications

- Flexibility in installation and use from variable actuation direction
- Space saving and simple installation through small size
- Screw covers prevent easy removal and the accumulation of dirt
- Strong resistance against cleaning agents (ECOLAB) makes this suitable for use in the food and packaging industries.

### Technical drawing

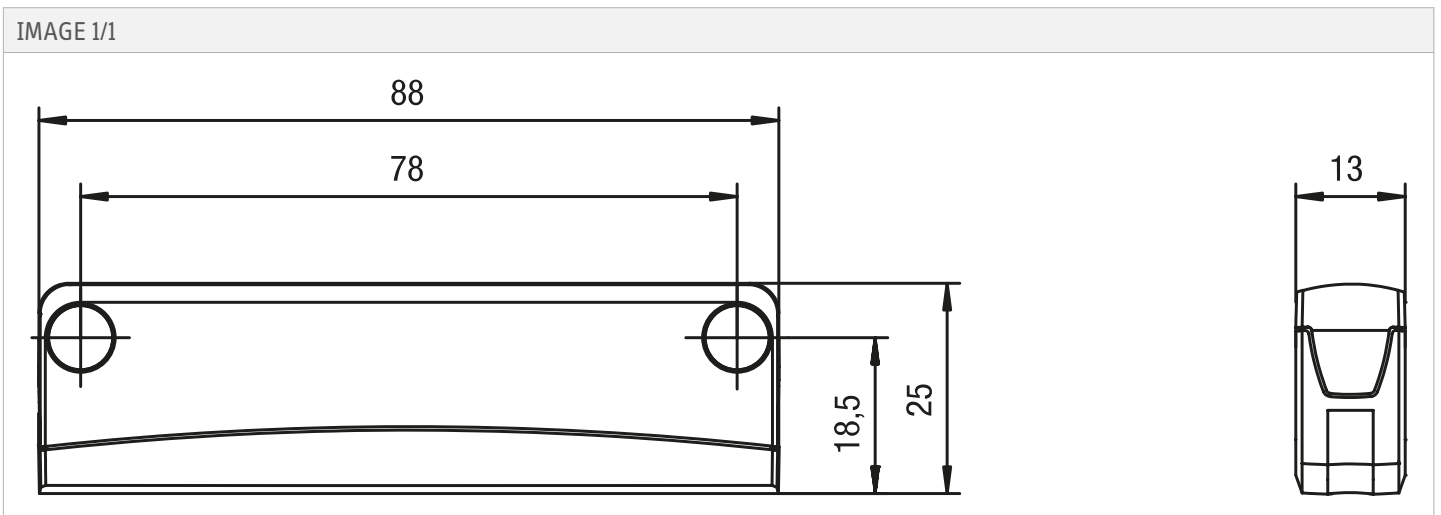

**Product options**

IMAGE 1/1

**ORDERING KEY**

165	MBK		Actuators for 165 MSK series
		001	Standard - front actuation
		101	Standard - 90° actuation
		201	Increased switching distance - front actuation
		301	Increased switching distance - 90° actuation

Article characteristics

Attribute	165MBK101	165MBK201	165MBK301
Coding acc. to EN ISO 14119		Low	
Suitable for sensor type(s)		165MSK	
Dimensions		88x25x13	
Housing material		PBT/PC	
Housing colour		grau/schwarz	
Mounting type		screwed	
Torque for fastening screws		0.7 N m	