



## Shuttle Lever Switch 151SL

### With flat handle.

Universal switch shuttle lever 151SL... with flat handle is designed for controlling the direction of travel in mobile machinery. The switch matrix can be individually adapted and configured for up to 9 functions. It can withstand high mechanical loads thanks to its robust design. The shuttle lever is individually adaptable. The Universal switch shuttle lever 151SL... is used in agricultural vehicles, construction machinery and self-propelled machinery. Using proven technology, these steering column switches are robust and reliable even under tough working conditions.

### Technical specifications

- High reliability and long service life thanks to contactless reed technology
- Robust and space-saving design
- Symbols can be individually customised
- Also available with round handle and push button switches
- Temperature range from -40 °C to +85 °C
- IP67 protection class for the electronic
- Long service life with 4 million operating cycles
- Available with up to 9 switching points

Technical drawing

IMAGE 1/1

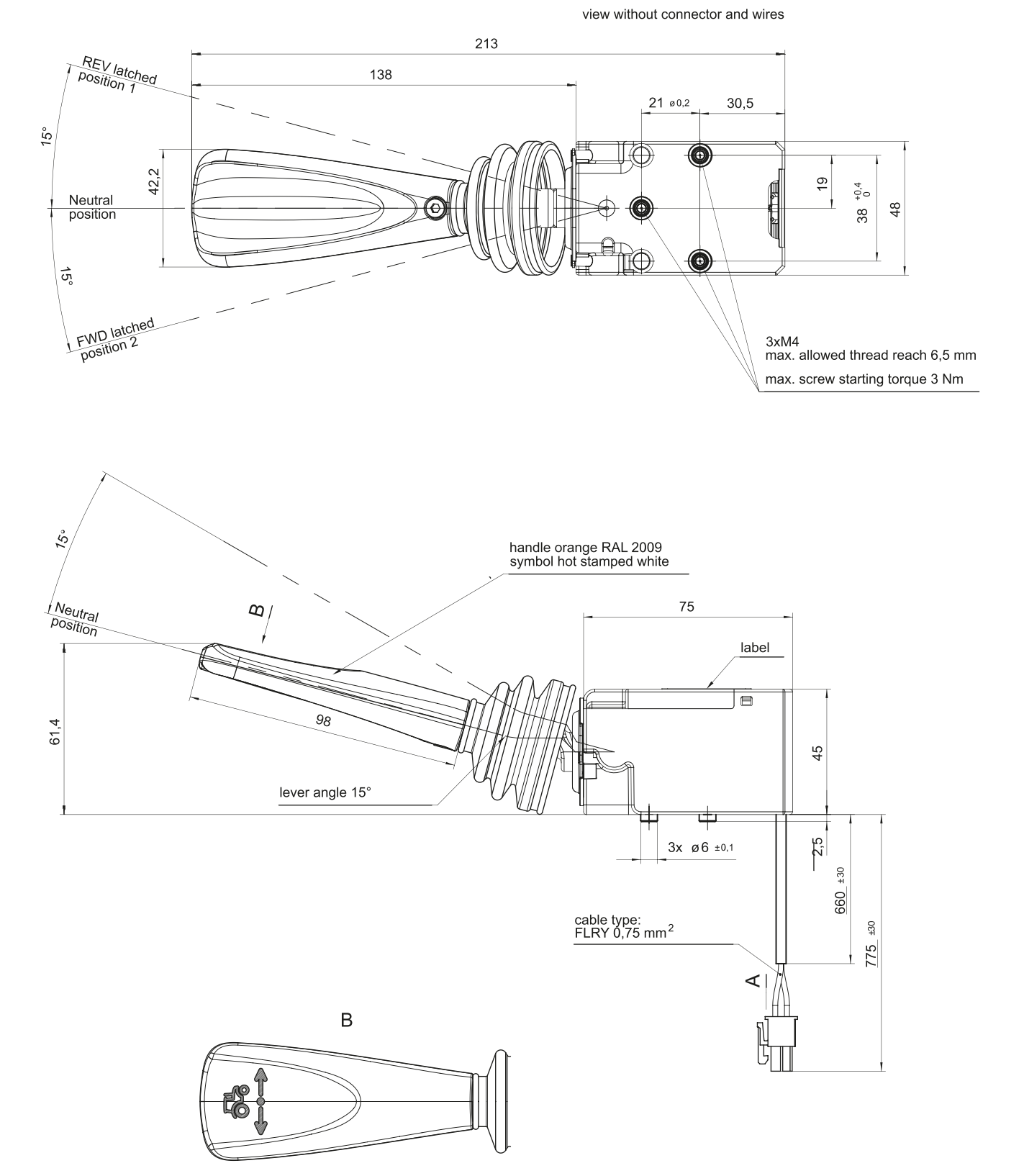

Article characteristics

Attribute	151SLX11S5A04	151SLX11S5A02	151SLY33S1A04	151SLY33S1A05
Max. switching voltage	24 V DC			
Contact form	NO			
Polarity reversal protection	no			
Max. lever load with specified lever length	100 mm / 550 N			
Deflection	± 15 °			
Protection class, electronic	IP67 DIN EN 60529			
Operating temperature min.	-30 °C			
Max. operating temperature	85 °C			
Min. storage temperature	-40 °C			
Max. storage temperature	85 °C			
Connector type	Molex MiniFit			
Cable type	FLRY			
Cable length	0.78 m			