

**MINISTOP**  
**Motor Brake Relay**  
**BI 9034**

Translation  
of the original instructions



02/60271

**Your advantages**

- Higher safety level and more economic by short stopping cycle
- Cost saving
- Compact design
- Easy to set-up, no need for current measuring instrument

**Features**

- According to IEC/EN 60947-4-2
- For all single and 3-phase asynchronous motors
- DC-brake with one way rectification up to max. 60 A
- Controlled by microcontroller
- Easily fitted to existing installations
- Wear free and maintenance free
- Integrated braking contactor
- DIN-rail mounting
- Adjustable braking current up to max. 60 A (controlled current)
- With integrated star-delta starting function
- With automatic standstill detection
- Variant /800 with short circuit contactor control for reduced brake delay time
- Width 90 mm

**Product Description**

The BI 9034 electronic braking relay enables the wear-free braking of asynchronous motors. The braking relay is used for drives that must be reliably braked for safety and functional reasons. An integrated standstill detection switches off the braking current after the motor has come to a standstill.

**Block Diagrams**

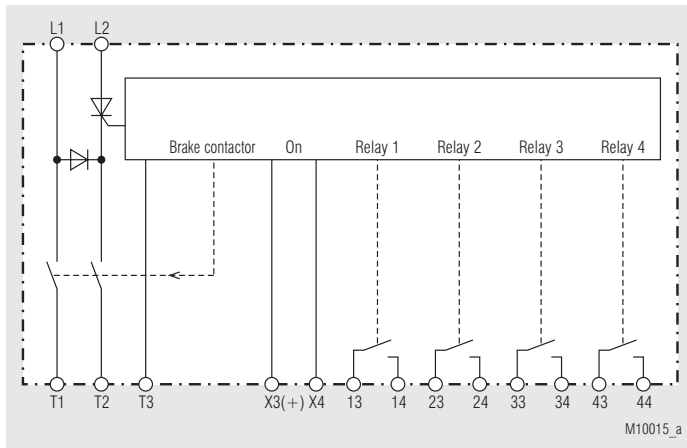

BI 9034

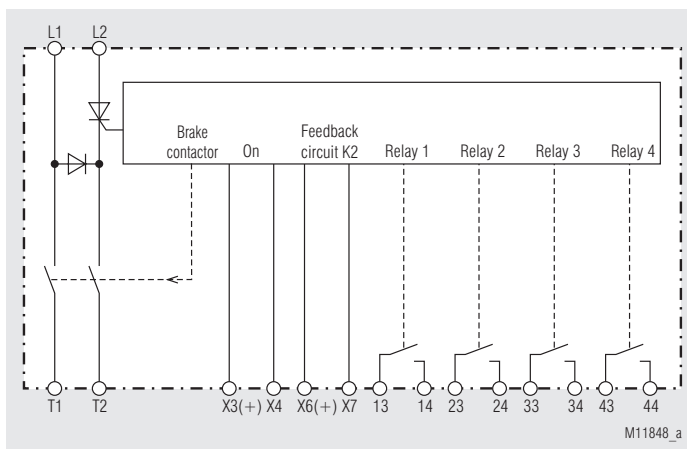

BI 9034/800

**Approvals and Markings**



**Applications**

- Saws
- Centrifuges
- Woodworking machines
- Textile machines
- Conveyors

**Function**

The supply voltage is connected to terminals L1-L2 and the interlock contact X5-X6 closes to enable the motor contactor. A green LED indicates operation. The motor can be started with an ON push button. Depending on the position of the rotary selector switch the motor starts direct on line or with star-delta start. The braking DC-voltage is generated on terminals T<sub>1</sub> and T<sub>2</sub>. The braking sequence is as follows:

Pressing the stop button de-energises the motor contactor. The closing of X3-X4 (contact of the motor contactor) starts the braking. After a safety time the braking contactor closes for the adjusted braking time and the braking current flows through the motor.

To reduce the brake delay time there is a variant /800 with a short circuit contactor control. By using a contactor controlled by relay 2, the motor windings are shortcircuited on motor stop. This cuts down the back emf very fast. The braking of the motor can be started faster. The braking cycle is time controlled, no standstill detection.

# Function Diagrams

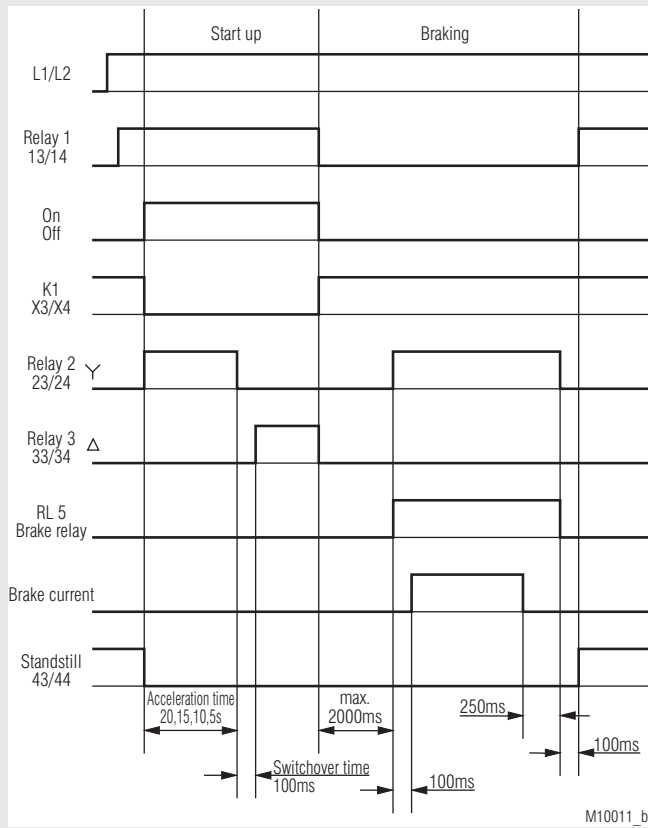

BI 9034 Function 1 ... 4

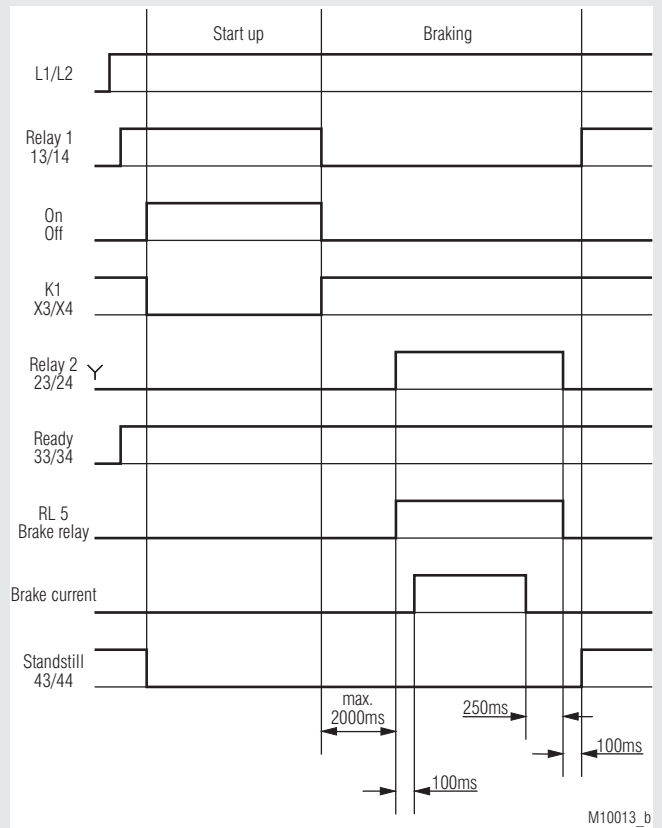

BI 9034 Function 5

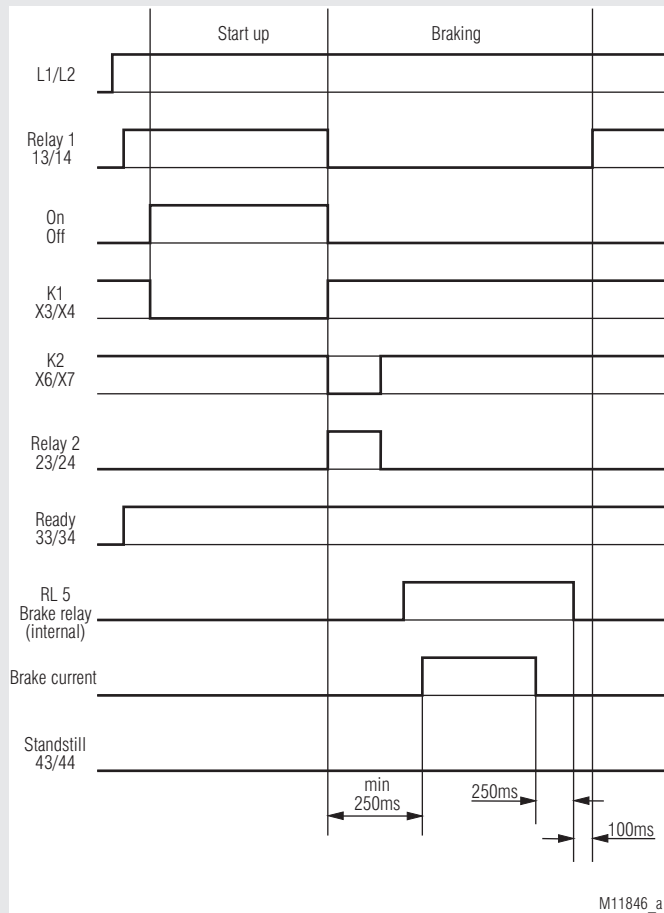

BI 9034/800

## Circuit Diagrams

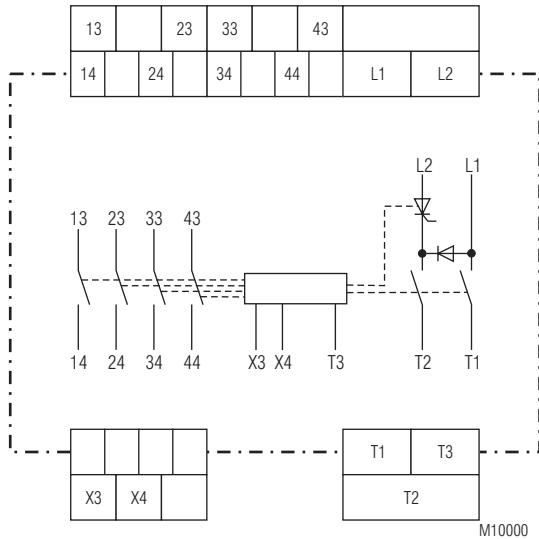

BI 9034

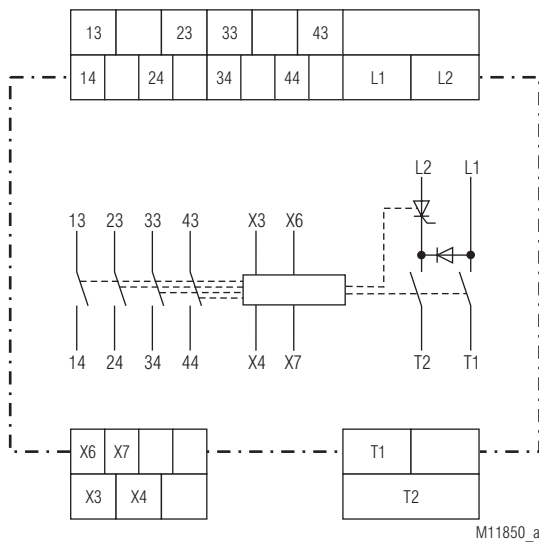

BI 9034/800

## Connection Terminals

Terminal designation	Signal description
L1	Phase voltage L1
L2	Phase voltage L2
T1	Motor connection T1
T2	Motor connection T2
T3	Motor connection T3 (stand still detection)
X3	(+) Feed back motor contactor
X4	Feed back motor contactor
13, 14	Monitoring relay 1
23, 24	Monitoring relay 2
33, 34	Monitoring relay 3
43, 44	Monitoring relay 4
X6	(+) Feed back short circuit contactor (/800 only)
X7	Feed back short circuit contactor (/800 only)

## Indicators

LED green „RUN“:	- Ready:	Permanent on
LED red „Error“	- Mains frequency out of tolerance:	1 flash
	- Braking current is not present:	2 flashes
	- Power semiconductors overheated:	Flashes 3 times
	- Synchronisation signal is not present:	Flashes 4 times
	- Temperature measuring circuit defective:	Flashes 5 times
	- Motor voltage not disconnected:	Flashes 6 times
	- Variant /800 only short circuit contactor not de-energized:	Flashes 7 times
LED yellow „I <sub>Br</sub> “	- Max. braking time 11 s Braking current is present	Permanent on
	- Max. braking time 31 s Braking current is present	Flashes

## Notes

Terminal 3 is the measuring input for standstill detection.

The BI 9034 can be also used without connecting T3. Standstill will be detected by the current measuring. It is important to make sure, that the braking current will flow longer than 2 s before stopping the motor. If the motor stops too early, the standstill will not be detected and the braking current will flow for the maximum braking time.

To have an optimum standstill detection make sure that the braking current is higher than the nominal current of the motor.

If the back-EMF of the motor drops only slowly the unit may have a braking delay of up to 2 s.

The variant /800 allows to reduce the brake delay time down to 250 ms.



### Installation Error!

- To avoid overloading the motor, the braking current should not exceed twice the rated motor current
- The use of capacitive loads can lead to the destruction of switching components of the motor control unit. Do not operate capacitive loads on the motor control unit.

Technical Data	
<b>Nominal Voltage <math>U_N</math>:</b>	AC 400 V $\pm$ 10 %
<b>Nominal frequency:</b>	50/60 Hz $\pm$ 3 Hz
<b>Permissible braking current:</b>	10 ... 60 A <sub>eff</sub>
<b>Duty-cycle at max. braking current:</b>	40 %
<b>Application category:</b>	60A:AC-53a:1-31:40-140

**Info** High ambient temperatures in combination with high braking currents may require a distance to adjacent devices or a reduction of the duty cycle.

<b>Braking voltage:</b>	DC 10 ... 190 V
<b>Max. braking time:</b>	11 s, 31 s
<b>Braking delay for fade out of back EMF:</b>	
BI 9034:	Auto optimising (0.2 ... 2 s)
BI 9034/800:	0.25 s via short circuit contactor
<b>Nominal consumption for control circuit:</b>	5 VA
<b>Fuses</b>	
Line protection (Coordination type 1):	Typ gL / 60 A
Semiconductor fuse (Coordination type 2):	Type gR / I <sup>2</sup> t 6600 A <sup>2</sup> s

**Info** **Coordination Type!**

- Coordination type 1 according to IEC 60947-4-1: The engine control unit is defective following a short circuit and must be replaced.
- Coordination type 2 according to IEC 60947-4-1: The engine control unit is still suitable for continued use following a short circuit.

## Output

<b>Contacts:</b>	4 NO contacts	2 A / AC 400 V
<b>Switching capacity to AC 15</b>		
NO contact:	3 A / AC 250 V	IEC/EN 60947-5-1
<b>Electrical life:</b>	10 <sup>5</sup> switch. cycles	IEC/EN 60947-5-1
<b>Mechanical life:</b>	10 <sup>6</sup> switch. cycles	IEC/EN 60947-5-1
<b>Permissible switching frequency:</b>	1800 switching cycles / h	
<b>Short circuit strength</b>		
Max. fuse rating:	4 A gG / gL	IEC/EN 60947-5-1

## General Data

<b>Operating mode:</b>	Continuous operation	
<b>Temperature range</b>		
Operation:	0 ... + 45 °C	
	At an altitude of > 1000 m the maximum permissible temperature reduces by 0.5 °C / 100 m	
Storage:	- 25 °C ... + 75 °C	
<b>Altitude:</b>	≤ 2000 m	
<b>Clearance and creepage distance</b>		
Rated impulse voltage / pollution degree		
Nominal voltage-heat sink:	6 kV / 2	EN 50178
Relay contacts to supply voltage:	4 kV / 2	IEC 60664-1
Control voltage to auxiliary voltage, motor voltage:	4 kV / 2	IEC 60664-1
Overvoltage:	III	
<b>EMC</b>		
<b>Interference resistance</b>		
Electrostatic discharge (ESD):	8 kV (air)	IEC/EN 61000-4-2
HF irradiation:		
80 MHz ... 1.0 GHz:	10 V / m	IEC/EN 61000-4-3
1.0 GHz ... 2.5 GHz:	3 V / m	IEC/EN 61000-4-3
2.5 GHz ... 2.7 GHz:	1 V / m	IEC/EN 61000-4-3
Fast transients:	2 kV	IEC/EN 61000-4-4
Surge between wires for power supply:	1 kV	IEC/EN 61000-4-5
Between wire and ground:	2 kV	IEC/EN 61000-4-5
HF-wire guided:	10 V	IEC/EN 61000-4-6
Voltage dips		IEC/EN 61000-4-11

Technical Data	
<b>Interference emission</b>	
Wire guided:	Limit value class B IEC/EN 60947-4-2
Radio irradiation:	Limit value class A*) IEC/EN 60947-4-2
<b>Danger of emitted interference!</b>	
May cause property damage	
*) The device is designed for use in an industrial environment (class A, EN 55011). Connecting the device to a low voltage supply grid (class B, EN 55011) may cause radio frequency interference. Take suitable measures to avoid this.	

## Degree of protection

Housing:	IP 40	IEC/EN 60529
Terminals:	IP 20	IEC/EN 60529
<b>Housing:</b>	Thermoplastic with V0 behaviour according to UL subject 94	
<b>Vibration resistance:</b>	Amplitude 0.35 mm, Frequency 10 ... 55 Hz, IEC/EN 60068-2-6	
<b>Climate resistance:</b>	25 / 075 / 04 IEC/EN 60068-1	
<b>Terminal designation:</b>	EN 50005	

## Wire connection

Load terminals:	1 x 10 mm <sup>2</sup> solid
	1 x 6 mm <sup>2</sup> stranded ferruled
	A current of 60 A or 80 A is permitted at a.m. duty cycles for 6 mm <sup>2</sup> wiring
Control terminals:	1 x 4 mm <sup>2</sup> solid or
	1 x 2.5 stranded ferruled (isolated) or
	2 x 1.5 mm <sup>2</sup> stranded ferruled (isolated)
	DIN 46228-1/-2/-3/-4 or
	2 x 2.5 mm <sup>2</sup> stranded ferruled
	DIN 46228-1/-2/-3

## Wire fixing

Load terminals:	Plus-minus terminal screws M 4 box terminals with self-lifting clamping piece
	1.2 Nm
Fixing torque:	
Control terminals:	Plus-minus terminal screws M 3.5 box terminals with self-lifting clamping piece
	0.8 Nm
Fixing torque:	
<b>Mounting:</b>	DIN rail IEC/EN 60715
<b>Rail standard:</b>	EN 50022
<b>Weight:</b>	780 g

## Dimensions

<b>Width x height x depth:</b>	90 x 85 x 120 mm
--------------------------------	------------------

Standard Type	
BI 9034	60 A AC 400 V 50 / 60 Hz 2 ... 11 s
Article number:	0062127
• Integrated braking contactor	
• DIN-rail mounting	
• Width:	90 mm

### Ordering Example

BI 9034 60 A AC 400 V 50 / 60 Hz 2 ... 11 s

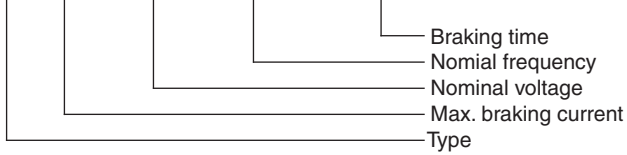

### Variants on Request

- Second control input e.g. to interrupt braking cycle
- 2 galvanic separated DC 24 V inputs e. g. for control via PLC
- Braking time 1 ... 31 s or to customers specification
- Relay function to customers specification
- Special voltages on request
- Device with time controlled braking cycle, without stand still monitoring, without star-delta-control on request

### Control Input

By opening a contact (motor contactor switches on) on terminals X3 (+ 24 V) and X4 (signal) star-delta starting begins when function 1 ... 4 is selected. After the adjusted time delay the delta contactor comes on and the brake units waits for the closing of the contact on X3-X4 (stop button is pressed). After closing of this contact the braking cycle starts.

The braking process can also be started without a contact at X3-X4. This is the case if no closed contact is detected at X3-X4 when the auxiliary voltage is switched on. In this case, the braking process is started as soon as the opening of the mains contactor is detected by the voltage dropping at the motor connection terminals. This can significantly increase the braking delay time.

The variant /800 has an extra input X6 (+ 24 V) and X7 (signal) to give feed back from the short circuit contactor K2. The braking cycle is only started when the feed back circuit after operation of the short circuit contactor is closed again.

### Monitoring Output

13, 14:	Interlock contact for motor contactor.
23, 24:	Control of star contactor of a star delta starter during start and braking.
33, 34	a) Control of delta contactor when function 1 ... 4 is selected b) Ready signal when function 5 is selected
43, 44	Standstill signal, resets on motor start or in case of a failure.

### Variante /800

13, 14:	Interlocking for motor contactor
23, 24:	Control of short circuit contactor
33, 44:	Ready signal
43, 44:	No function

On device failure all contacts open

### Adjustment Facilities

BI 9034:

Potentiometer	Description	Grundeinstellung
$I_{Br}$	Braking current	Fully anti-clockwise
Fkt	Function	Fully anti-clockwise

BI 9034/800:

Potentiometer	Benennung	Grundeinstellung
$t_{Br}$	Braking time	Fully clockwise

The braking current is controlled according to the adjusted value in Ampere.

For optimum braking the setting of the current should be max. 1.8 to 2 times the motor current. This corresponds to the saturation current of the magnetic field used to brake the motor. A higher current only overheats the motor. A higher braking efficiency can be obtained by using 2 or more stator windings. The permitted duty cycle is depending on the actual braking current and the ambient temperature.

The different functions of the brake unit can be selected with rotary switch Fkt

Fkt 1 ... 4:	Star-Delta-control with internal timing
	Relay 1 - Motor contactor
	Relay 2 - Star-contactor
	Relay 3 - Triangle contactor
	Relay 4 - Stand still

Acceleration time (star-contactor):	Fkt 1 - 20 s
	Fkt 2 - 15 s
	Fkt 3 - 10 s
	Fkt 4 - 5 s

Fkt 5:	Star-Delta-control with external timing
	Relay 1 - Motor contactor
	Relay 2 - Star-contactor
	Relay 3 - Ready
	Relay 4 - Stand still

Fkt. 6-8:	Not occupied. Are treated as fkt. 5.
-----------	--------------------------------------

### Set-up Procedure

- Connect the motor brake relay BI 9034 in accordance to the connection example and make sure to connect the same phases between (L1, L2) and /T1, T2). Make sure that the interlocking contact 13, 14 is wired in series to the coil of the motor contactor so that the motor contactor cannot switch on, while the braking current is flowing
- Select function with rotary switch Fkt
- Set the braking current on potentiometer  $I_{Br}$  (braking time at variant /800). To avoid overloading of the motor set the current to max. two times the nominal motor current
- The braking time of the BI 9034 (except for BI 9034/800) cannot be adjusted. Due to the standstill detection it is self-optimizing. If L3 is not connected to T3, standstill detection is provided by measuring the braking current.
- If no standstill is detected, the BI 9034 stops braking after 10 s e.g. 30 s

### Fault Indication by Flashing Code

During normal operation failure messages may occur. The messages are indicated by a flashing sequence of the „Error“ LED

Flashes	Fault	Reason	Failure recovery
1 x	Mains frequency out of tolerance	Wrong mains frequency	Device not suitable for the frequency. Contact manufacturer
2 x	Braking current is not present	Braking current circuit broken	Check the wiring
		Motor coil resistance is too high	Set braking current lower until the error disappears
3 x	Power semiconductors overheated	Permitted duty cycle exceeded	Decrease current and set the braking time longer. Wait till heat sink cools down
4 x	Synchronisations signal is not present	Unit defective	The unit has to be repaired
		Or temporary interruption of power supply	Switch unit Off and On
5 x	Temperature measuring circuit defective	Unit defective	The unit has to be repaired
		Or overtemperature on power semiconductors while switching on	Wait till heat sink cools down
6 x	Motor is still connected to voltage while braking should start already	Motor contactor welded	Change motor contactor
		Wiring incorrect	Check wiring
7 x	Short circuit contactor not de-energised when braking cycle should be started	Short circuit contactor welded, faulty wiring	Exchange short circuit contactor, check wiring

## Connection Examples

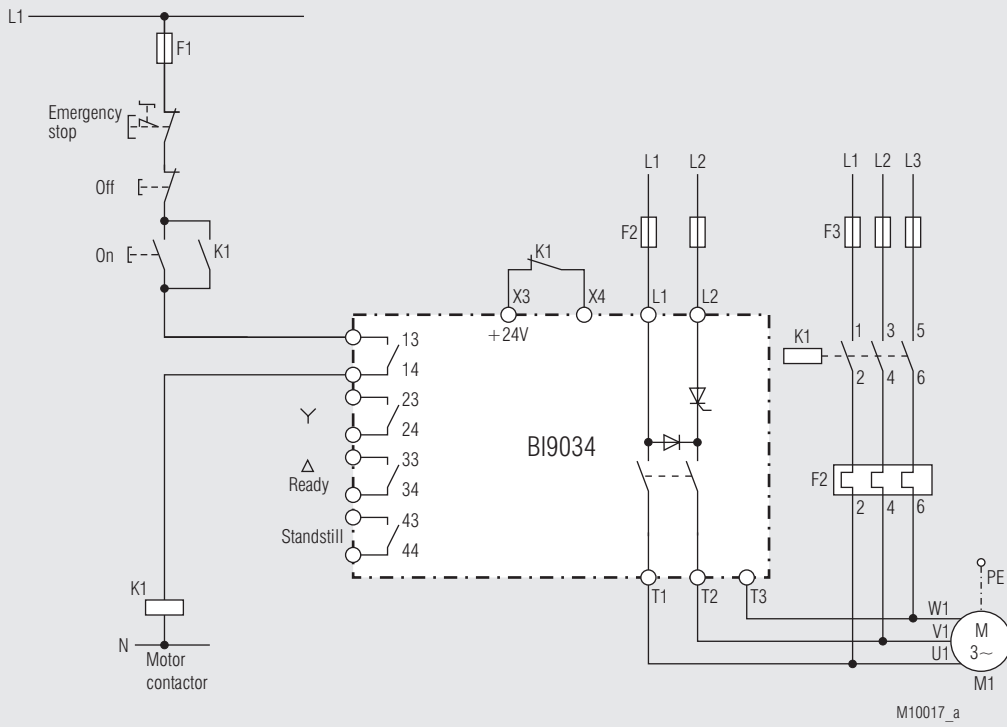

BI 9034 without star-delta-control

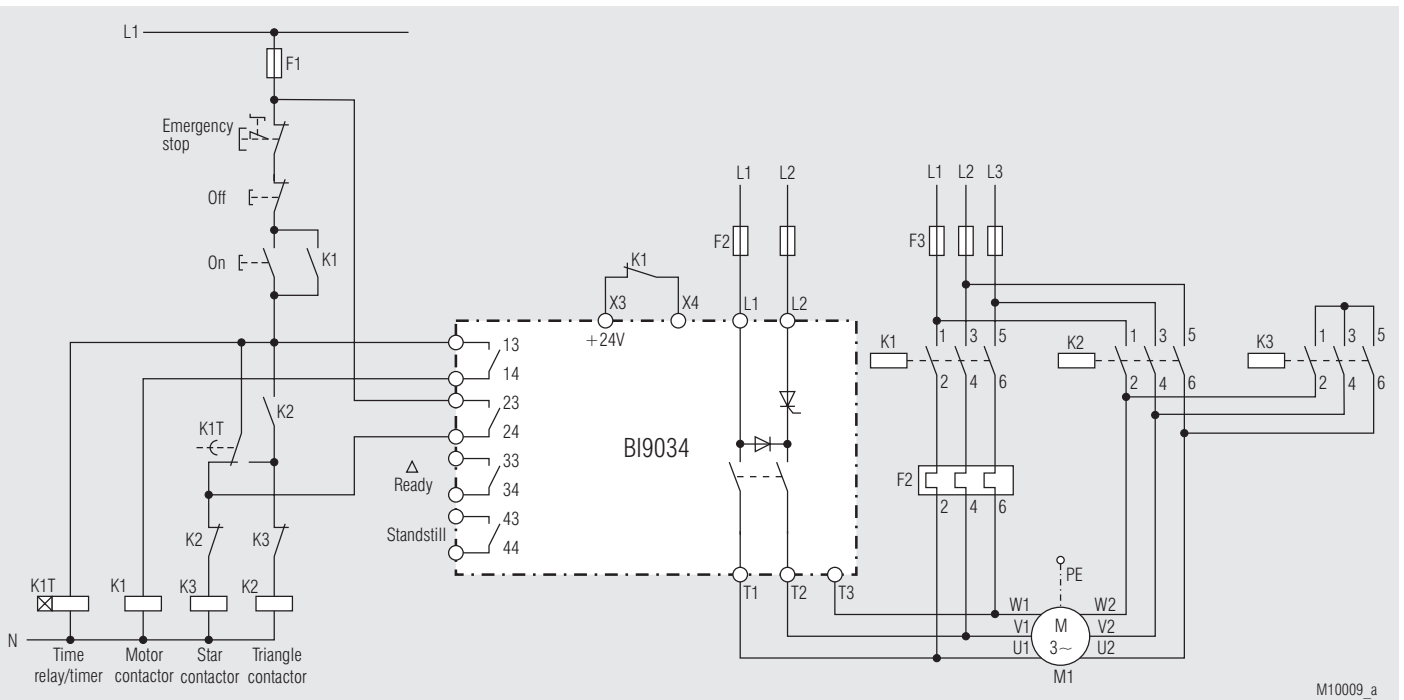

BI 9034 with external star-delta-control

## Connection Example

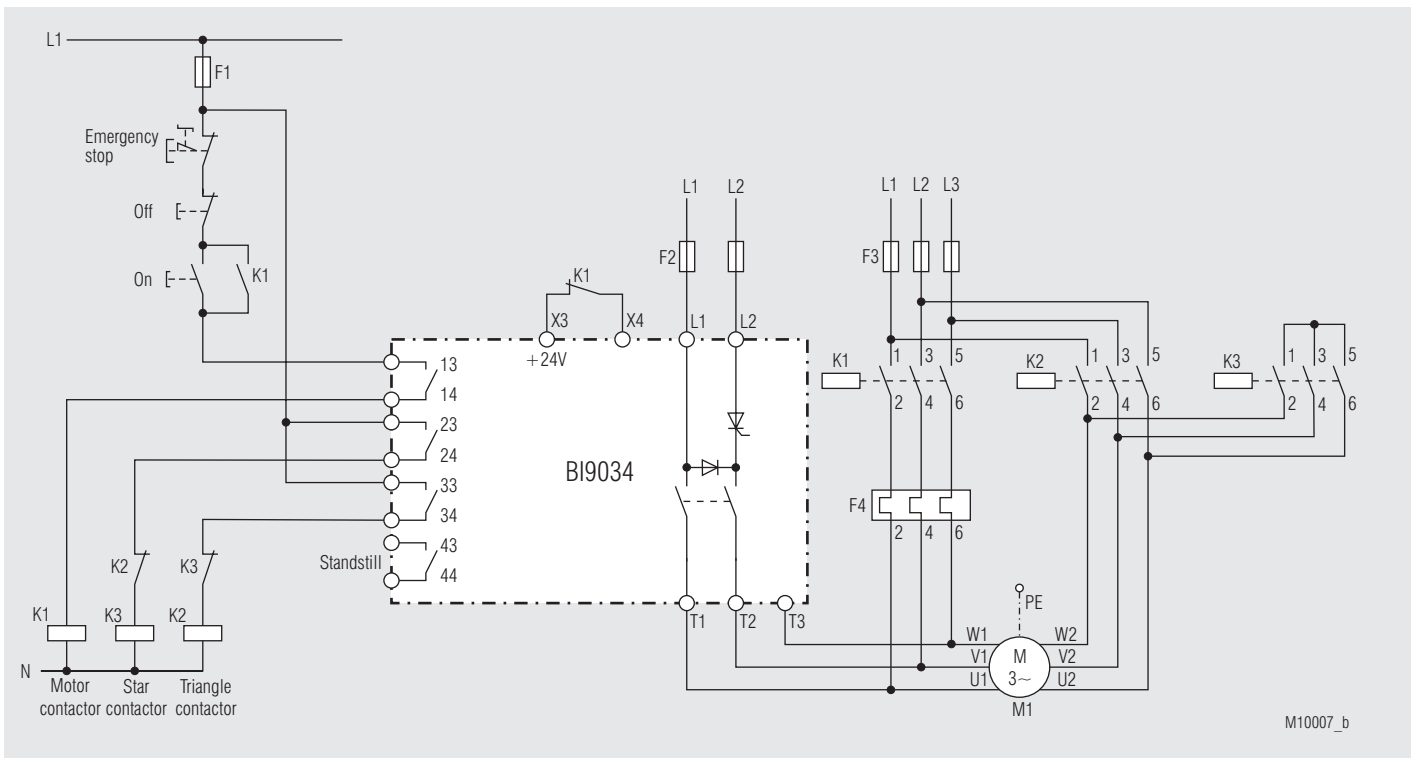

BI 9034 with internal star-delta-control

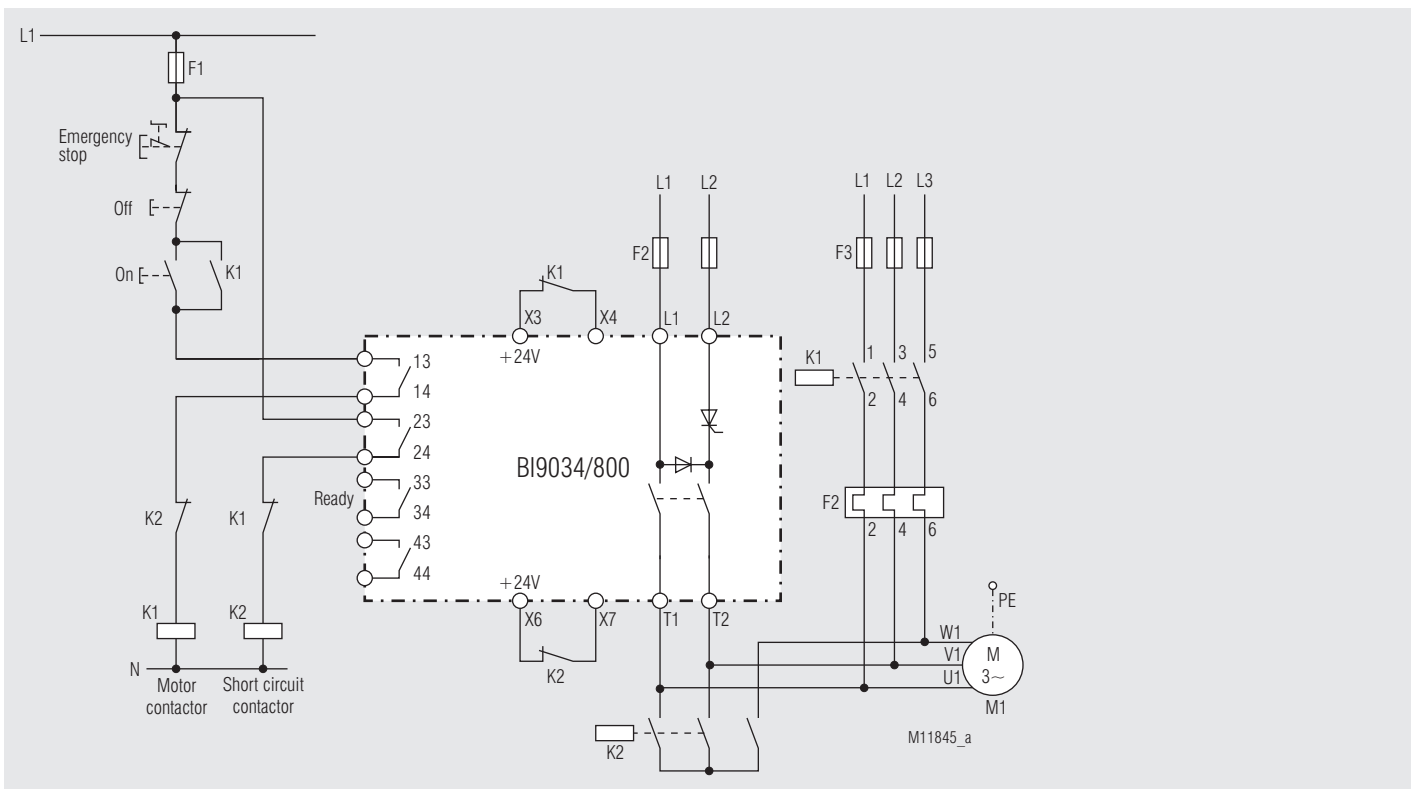

BI 9034/800 with reduced brake delay time