

[Article Page](#)

Product Description

color sensor

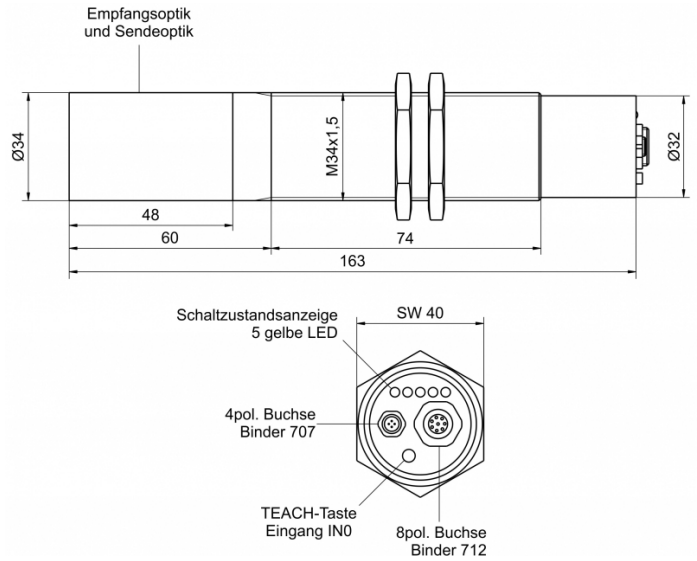
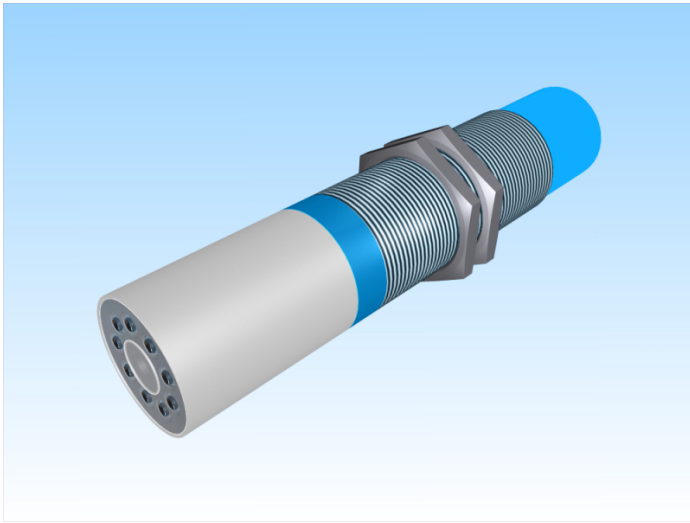

Name  
Order number  
Switch type

SPECTRO-3-30-COF-d1.3  
08386211043

Signal Type  
Illuminant  
Connection

digital  
PNP/NPN  
 White light

Polschema

Socket

SPS  
Binder 712, 8 pol.

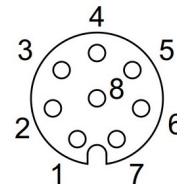

- 1 wh GND (0V)
- 2 bn +24V DC (±10%)
- 3 gn IN 0
- 4 ye OUT 0
- 5 gy OUT 1
- 6 pk OUT 2
- 7 bu OUT 3
- 8 rd OUT 4

PC  
Binder 707, 4 pol.

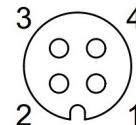

- 1 +24V DC
- 2 GND (0V)
- 3 RxD
- 4 TxD

M34 x 163

Dimension (in mm)  
Technical Specification  
Special features

3-color filter detector (TRUE COLOR detector, "human color perception"), Color and gray scale detection

Operating voltage	22,6 - 26,4 V DC
Max. load current	100 mA
No load current	≤ 180 mA
Switching frequency	35 kHz
Temperature drift	< 0,01 % / °C
Repeat accuracy	+/- 1 Digit in the X, Y color range at 12-bit A/D conversion
Swiching state	LED
Digital output	, OUT 0 ... OUT 4, digital (0V/+Ub), 100 mA max. switching current npn, pnp-output available (bright-, dark-switching can be switched over)
Natural extraneous light	5000 Lux in AC-mode
Artificial extraneous light	5000 Lux in AC-mode
Material of light outlet	Glas
Impulse delay	einstellbar/ adjustable 0 ms ... 100 ms
Amplifying adjustable	8 fach/ 8-fold
Tolerance limit adjustable	ja
Working range	from 25 to 55 mm
Short-circuit proof	yes
Overload protection	yes
Reverse voltage protection	yes
Protection category	IP64 (Optik IP67)
EMC-level	DIN EN 60947-5-2
Housing material	Aluminum
Termination	connection to PLC: 8-pole fem. connector (Binder Series 712), connection to PC: 4-pole fem. connector (Binder Series 707)

**Errors and omissions exceptet**