

## User Manual

## English translation

### Correct Use



ZCode-LC/LCE are coded tamperproof magnetic safety switches with transistor output. They are simple to install, completely dust- and waterproofed and can switch with no contact. Anything other than the ZCode actuator will not trigger the switch. In combination with a Safety relay ( e.g. ZANDER SR-Series, MINOS SD-Series), a safety logic device (e.g. ZANDER MINOS SL-Series) or a safety PLC (e.g. ZANDER TALOS-Series) the switches are self-monitoring with short-circuit monitoring. (ZCode-LCE as stainless steel type for rough and hygiene critical environments and applications)

- Coded sensor with LED - high degree of anti tamper.
- 2 non-contact safety outputs, 1 non-contact auxiliary output
- Compatible to most safety logic devices, safety relays and safety PLCs
- Easy to install
- Can also be used on poorly aligned safety doors
- Wide tolerance to misalignment
- Fully sealed - enclosure protection IP67 and IP69K
- Series Connection up to 3 switches to one ZANDER SR“C“-/ MINOS SD1E safety relay or one ZANDER MINOS SL“1“ safety logic
- Certified up to PL e, Cat. 4 according to EN ISO 13849-1, Construction type 4 according to ISO 14119)
- ZCode-LCE Stainless Steel switches for applications in rough environments and high hygiene requirements, e.g. food, pharma and process industry (CIP, SIP cleaning)
- High operational life without moving or touching parts
- Super compact dimensions



ZCode-LC

ZCode-LCE



### Function

Coded magnetic non contact safety switches ZCode are designed to interlock hinge, sliding or removal guard doors (see Fig. 1).

The outputs of the ZCode will be switched off, if the guard door is opened whereupon the safety outputs of the wired emergency stop device shut down the system securely.

The ZCode operates contactless with a coded magnetic sensing system which provides a wide sensing distance (up to 10 mm) and provides a high tolerance to misalignment. They can be fitted behind stainless steel and can operate from 4 directions even in dusty, hot and humid environments.



Figure 1: Application positions at protection device

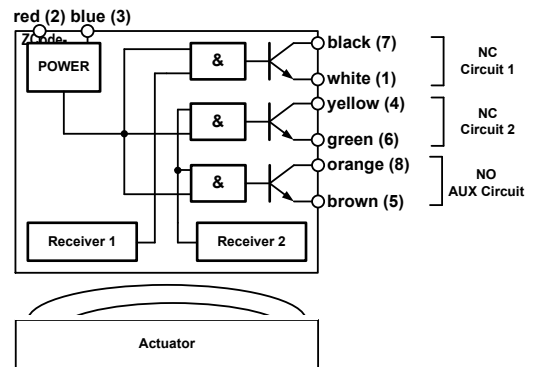

Figure 2: Block Diagram

### Mounting

M4 mounting bolts must be used to fix the switches and actuators. Tightening torque for mounting bolts mustn't be more than 2 Nm. Always mount on to non ferrous materials. The recommended setting gap is 5 mm.

The safety switches must not be used as a mechanical stop. The actuators must not be allowed to strike the switch. An adjustment by striking with a hammer is inadmissible. Do not mount adjacent switches or actuators closer than 30 mm. Typical misalignment tolerance after setting is 5 mm in any plane/direction (see Figure 3).

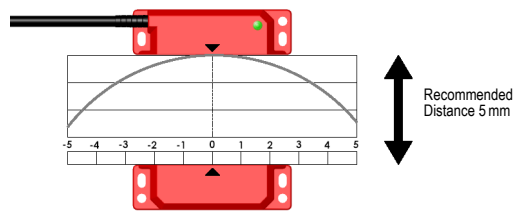

Figure 3: 5 mm misalignment tolerance after setting

### Safety Precautions



- Installation and commissioning of the device must be carried out **only by competent personnel** with appropriate experience of machine control integration, who have read and understood these user manual .
- Observe the country-specific regulations when installing the device.
- The electrical connection of the device is only allowed to be made with the device isolated.
- The wiring of the device must comply with the instructions in this user information, otherwise there is a risk that the safety function will be lost.
- It is not allowed to open the device, tamper with the device or bypass the safety guards.
- All relevant safety regulations and standards are to be observed.
- It is the responsibility of the user to ensure the correct overall functionality of its systems and machines.
- Failure to observe the safety regulations can result in death, serious injury and serious damage.
- The Risk Assessment for the particular application should include the risk of spare actuators. Spare actuators should not be readily available and must be securely controlled.

## User Manual

### Electrical Connection

The installation of all ZCode safety switches must be in accordance with a risk assessment for the individual application. For monitoring the ZCode switches, the two redundant outputs must be connected to a commercially available safety emergency stop relay (e.g. ZANDER SR“C”, MINOS SD1E), a safety logic device (e.g. ZANDER MINOS SL1D / SL1E) or a dual channel connection has to be made with the inputs of a safety PLC (e.g. ZANDER TALOS-Series).

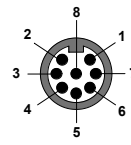

View of M12-Connector

M12	Colour	Signal
2	red	operating voltage, 24V
3	blue	operating voltage, 0V
7	black	safety contact 1, NC
1	white	safety contact 1, NC
4	yellow	safety contact 2, NC
6	green	safety contact 2, NC
8	orange	auxiliary contact AUX, NO
5	brown	auxiliary contact AUX, NO

Figure 4: Terminals M12 Connector

### Applications/ Wiring Diagrams

Up to 3 ZCode switches can be connected to one commercially available emergency stop safety relay or safety logic device (e.g. Fig. 5 to 10: wiring examples ZCode with ZANDER SR“C”, MINOS SD1E and MINOS SL1D / SL1E).

When several sensors are placed in series, make sure that the safety relay or the safety logic is applied with sufficient supply voltage of min. 24 V. (relevant datasheets must be taken into account!)

### Safety Relay, wiring example: ZANDER SR“C”

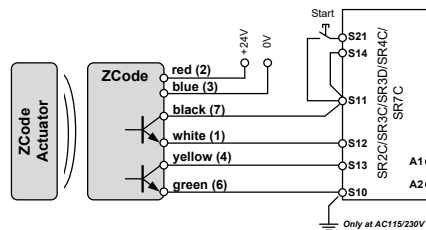

Figure 5: Single connection of a ZCode to one ZANDER SR“C” (up to category 4, PL e)

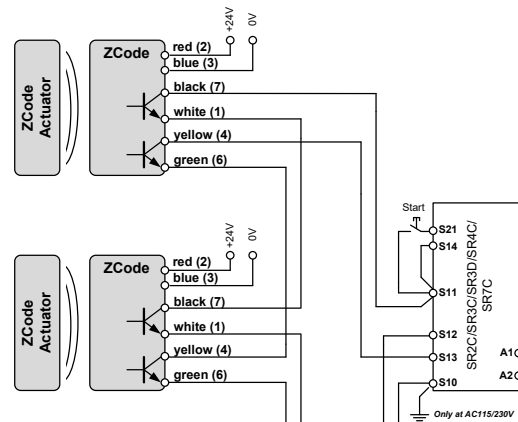

Figure 7: Connecting up to 3 ZCode in series to one ZANDER SR“C” (up to category 3, PL d)

### Safety Relay, wiring example: ZANDER MINOS SD1E

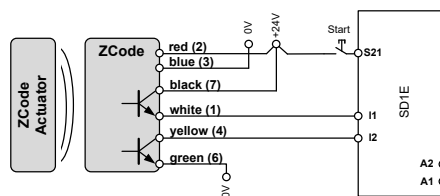

Figure 6: Single connection of a ZCode to one ZANDER MINOS SD1E (up to category 4, PL e)

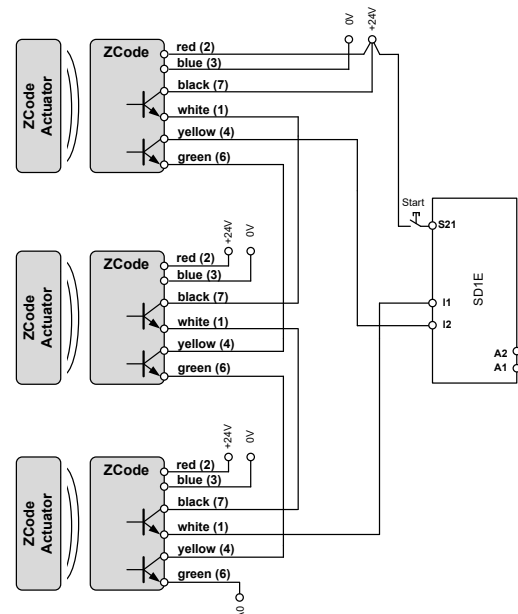

Figure 8: Connecting up to 3 ZCode in series to one ZANDER SD1E (up to category 3, PL d)

## User Manual

Safety Logic,  
wiring example:  
ZANDER  
MINOS SL1E/SL1D

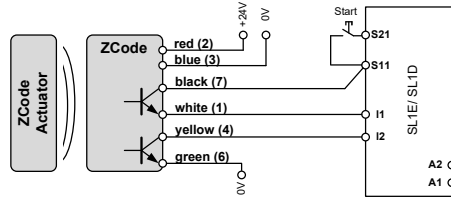

Figure 9 : Single connection of a ZCode to one ZANDER MINOS SL1D (up to category 3, PL d) / SL1E (up to category 4, PL e)

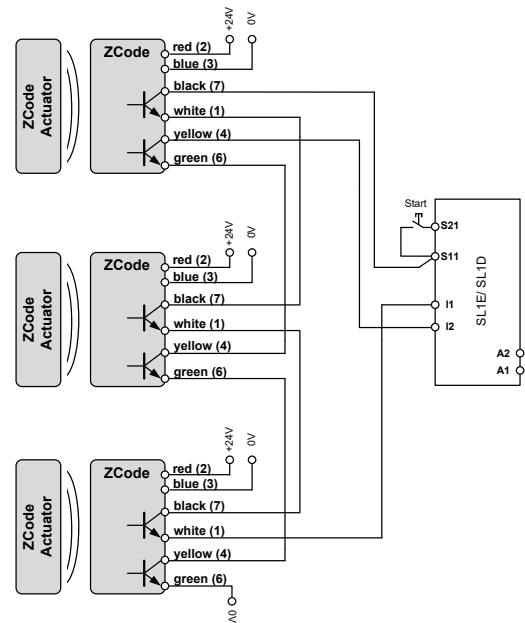

Figure 10: Connecting up to 3 ZCode in series to one ZANDER MINOS SL1D / SL1E (up to category 3, PL d)

Safety PLC,  
wiring example:  
ZANDER TALOS  
standard  
programs  
PR07 and PR08

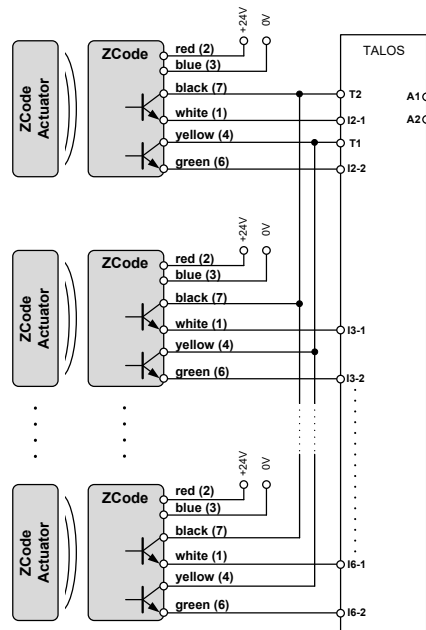

Figure 11 : Connection of ZCodes to one ZANDER TALOS according to the configurations of the standard programs PR07 and PR08 (up to category 4, PL e)

### Commissioning Procedure



**Attention:** During commissioning, the items listed under „Electrical Connection“ must be considered. (see above)

#### 1. Mounting the device:

Mount the device on the safety gate according to the instructions listed under "Mounting". Pay attention to the correct fitting and distance between the switch and actuator.

#### 2. Wiring:

Wire the switch according to your application and performance level with the used safety relay, safety logic or PLC (see e.g. Fig. 5 to Fig. 11).

**Caution:** The wiring instruction in the user information of the used safety device must be considered. Wiring only in de-energized state.

#### 3. Starting the device:

Switch on the operating voltage for the safety switch and safety device.

#### 4. Check your application:

After installation always check each switch function by opening and closing each guard individually in turn. Ensure that the green LED at the switch and also the respectively diagnostic LEDs of the safety device are lit while the door is closed and are extinguished when the door is open.

#### 5. Triggering safety function:

Check that the machine stops and cannot be re-started when a switch or a door is open.

## User Manual

### Maintenance

**Monthly:** Check alignment of actuator and look for signs of mechanical damage to the switch casing.

For applications where infrequent guard access is foreseeable, the system must have a manual function test to detect a possible accumulation of faults. At least once per month for PL e Cat. 3/4 or once per year for PL d Cat. 3 (ISO 13849-1). Where possible it is recommended that the control system of the machine demands and monitors these tests, and stops or prevents the machine from starting if the test is not done (ISO 14119).

Check each switch function by opening and closing each guard individually in turn and ensure that the green LED on the switch and the appropriate LED's on the Safety Relay or Control Device are illuminated when the switch is closed and are extinguished when the switch is open. Check that the machine stops and cannot be re-started when each switch is open.

Never repair any switch, actuator or integral cables. Replace any switch displaying signs of mechanical damage to casing or cables.

The device is otherwise maintenance free, provided that it was installed properly.

### What to Do in Case of a Fault?

#### Device does not switch on:

- Check the wiring by comparing it to the wiring diagrams.
- Check the safety switch for correct adjustment.
- Check if the green LED is lit when the switch is closed.
- Check the operating voltage.

If the fault still exists, perform the steps listed under

"Commissioning Procedure".

If these steps do not remedy the fault either, return the device to the manufacturer for examination.

**Opening the device is impermissible and will void the warranty.**

### Safety Characteristics According to EN ISO 13849-1 EN ISO 62061

The device is certified according to DIN EN ISO 13849-1 up to a Performance Level of PL e .

The specified PL (for applications according to Fig. 5 to Fig. 11) values were determined under the following worst-case conditions for a guard door monitoring.

#### Safety Characteristics according to DIN EN ISO 13849-1 / EN 62061

Performance Level	e (depending on the application; see Fig. 5 to Fig. 11)
Category	4
MTTF <sub>d</sub>	866 years
Safety Integrity Level	SILCL 3
PFH <sub>d</sub> (1/h)	2,6 x 10 <sup>-10</sup> (1/h)
Proof Test Interval	20 years

### Techn. Data

Correspondents to the standards	ISO 13849-1; EN 62061; EN ISO 14119; EN 60204-1 EN 60947-5-3; UL 508, CSA-C22.2 No.14
Approvals	CE, TÜV, UL
Power Supply	DC 24 V, +/- 10 %, max. 25 mA
Contact rating safety outputs	DC 24 V, max. 200 mA, short circuit proof
Contact rating auxiliary output	DC 24 V, max. 200 mA, short circuit proof
Contact release time	max. 2 ms
Dielectric withstand	AC 250 V
Insulation resistance	100 MOhm
Recommended setting gap	5 mm
Switching distance, max.	Sao 10 mm Close / Sar 20 mm Open
Tolerance to misalignment	5 mm in any direction from 5 mm setting gap
Switching frequency	max. 1,0 Hz
Approach speed	200 mm/min - 1000 mm/s
Body material	Red Plastic / Stainless Steel 316
Dimensions	88 x 25 x 14 mm
Weight	approx. 200 g (Plastic) / approx. 300 g (Stainless Steel)
IP Protection	IP67, IP69K (with M12-connector IP67)
Temperature Range	-25 °C to +80 °C Plastic, +105 °C Stainless Steel (CIP, SIP cleaning)
Shock Resistance	11 ms 30 g according to IEC 68-2-27
Vibration Resistance	10 - 55 Hz 1 mm according to IEC 68-2-6
Cable Type	PVC 8 core, 6 mm O.D. for 2 NC/ 1 NO, 0.25 mm <sup>2</sup>
Mounting	each 2 x M4 screws; tightening torque max. 2 Nm; any position

