

User Information

English translation

Correct Use



ZCode-LR is a coded tamperproof safety switch for the use in machinery and plant engineering. Coding is achieved by using radio frequency (RFID) and magnetic technology, both principles need to be satisfied for the switch to operate safely. These redundant diverse structure provides the highest degree of anti-tamper, virtually impossible to override. The high specification plastic housings allow the use in almost any environments. In combination with a Safety relay (e.g. ZANDER SR-Series, MINOS SD-Series), a safety logic device (e.g. ZANDER MINOS SL-Series) or a safety PLC (e.g. ZANDER TALOS-Series) the switches are self-monitoring with short-circuit protection.

- High degree of anti-tamper due to redundant diverse structure (RFID and magnet)
- 2 non-contact safety outputs and 1 non-contact auxiliary output
- Compatible to most safety logic devices, safety relays and safety PLCs
- Easy to install
- Unicode (activation by one factory set actuator) and Mastercode (any actuator will operate any switch) types available
- Wide tolerance to guard misalignment
- High specification housing IP69K, IP67
- Series Connection up to 20 switches to one ZANDER SR“C“-/ MINOS SD1E safety relay or one ZANDER MINOS SL“1“ safety logic
- Certified up to PL e, Cat. 4 according to EN ISO 13849-1, Construction type 4 according to ISO 14119)
- Switches achieve Coding Levels Type 4, low coding with master code and Type 4, high coding with Unicode version according to EN ISO 14119
- High operational life without moving or touching parts.
- Super compact dimensions



Function

Coded RFID magnetic non contact safety switches ZCode are designed to interlock hinge, sliding or removal guard doors (see Fig. 1).

The outputs of the ZCode-LR will be switched off, if the guard door is opened whereupon the safety outputs of the wired emergency stop device shut down the system securely.

The ZCode-LR operates contactless with an RFID and coded magnetic sensing system which provides a wide sensing distance (up to 10 mm) and provides a high tolerance to misalignment. They can be fitted behind stainless steel and can operate from 4 directions even in dusty, hot and humid environments.

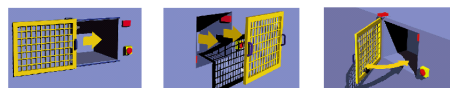

Fig. 1: Application examples

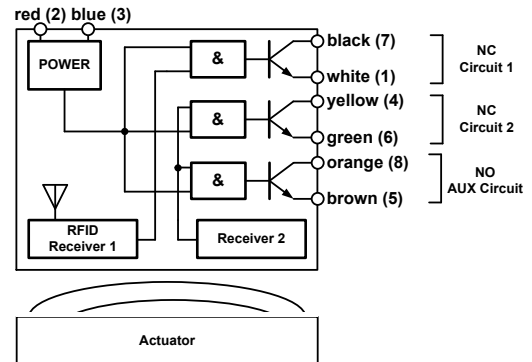

Fig. 2: Block diagram

Installation

M4 mounting bolts must be used to fix the switches and actuators, max. tightening torque 2 Nm. Always mount on to non ferrous materials. The recommended setting gap is 5 mm.

The safety switches must not be used as a mechanical stop. The actuators must not be allowed to strike the switch. An adjustment by striking with a hammer is inadmissible. Do not mount adjacent switches or actuators closer than 30 mm. Typical misalignment tolerance after setting is 5 mm in any plane.



Fig. 3: Operating direction

Safety Precautions



- Installation and commissioning of the device must be carried out **only by competent personnel** with appropriate experience of machine control integration, who have read and understood these user manual .
- Observe the country-specific regulations when installing the device.
- The electrical connection of the device is only allowed to be made with the device isolated.
- The wiring of the device must comply with the instructions in this user information, otherwise there is a risk that the safety function will be lost.
- It is not allowed to open the device, tamper with the device or bypass the safety guards.

- All relevant safety regulations and standards are to be observed.
- It is the responsibility of the user to ensure the correct overall functionality of its systems and machines.
- Failure to observe the safety regulations can result in death, serious injury and serious damage.
- The Risk Assessment for the particular application should include the risk of spare actuators. Spare actuators should not be readily available and must be securely controlled.
- Record any RFID codes as required by factory rules or with reference to any risk assessment for the particular application and user location.

User Information

Electrical Connection

The installation of all ZCode safety switches must be in accordance with a risk assessment for the individual application. For monitoring the ZCode switches, the two redundant outputs must be connected to a commercially available safety emergency stop relay (e.g. ZANDER SR“C”, MINOS SD1E), a safety logic device (e.g. ZANDER MINOS SL1D / SL1E) or a dual channel connection has to be made with the inputs of a safety PLC (e.g. ZANDER TALOS-Series).

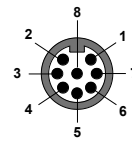

View of M12-Connector

M12	Colour	Signal
2	red	operating voltage, 24V
3	blue	operating voltage, 0V
7	black	safety contact 1, NC
1	white	safety contact 1, NC
4	yellow	safety contact 2, NC
6	green	safety contact 2, NC
8	orange	auxiliary contact AUX, NO
5	brown	auxiliary contact AUX, NO

Figure 4: Terminals M12 Connector

Applications/ Wiring Diagrams

Up to 20 ZCode switches can be connected to one commercially available emergency stop safety relay or safety logic device (e.g. Fig. 5 to 10: wiring examples ZCode with ZANDER SR “C”, MINOS SD1E and MINOS

SL1D / SL1E). When more than 10 sensors are placed in series, make sure that the safety relay or the safety logic is applied with sufficient supply voltage of min. 24 V. (relevant datasheets must be taken into account!)

Safety Relay, wiring example: ZANDER SR “C”

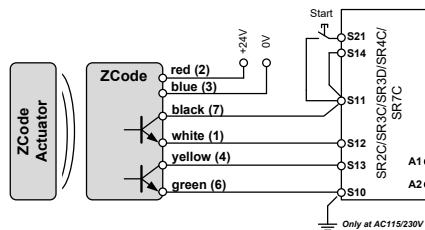

Figure 5: Single connection of a ZCode to one ZANDER SR“C” (up to category 4, PL e)

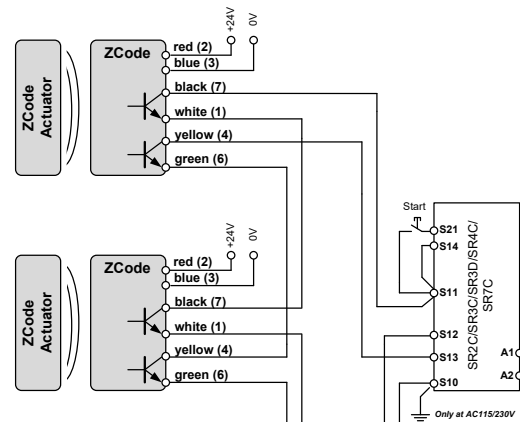

Figure 7: Connecting of 3 (up to 20) ZCode in series to one ZANDER SR“C” (up to category 3, PL d)

Safety Relay, wiring example: ZANDER MINOS SD1E

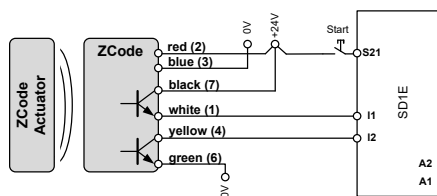

Figure 6: Single connection of a ZCode to one ZANDER MINOS SD1E (up to category 4, PL e)

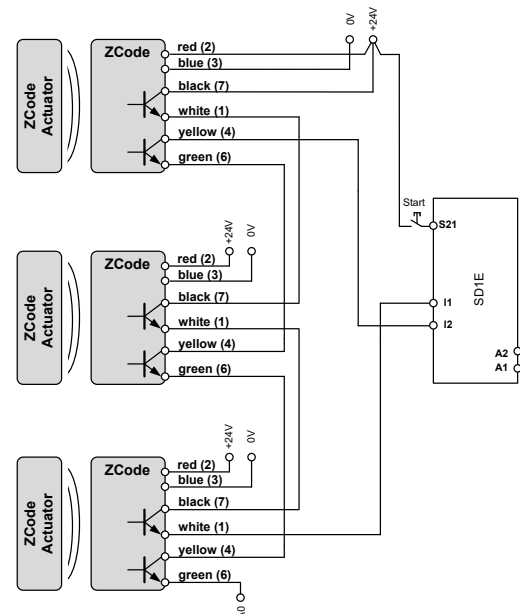

Figure 8: Connecting of 3 (up to 20) ZCode in series to one ZANDER SD1E (up to category 3, PL d)

User Information

Safety Logic,
wiring example:
ZANDER
MINOS SL1E/SL1D

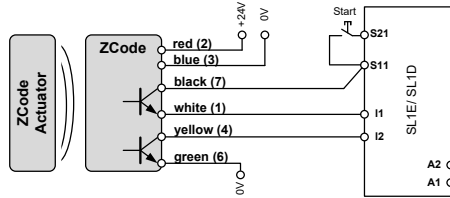

Figure 9 : Single connection of a ZCode to one ZANDER MINOS SL1D (up to category 3, PL d) / SL1E (up to category 4, PL e)

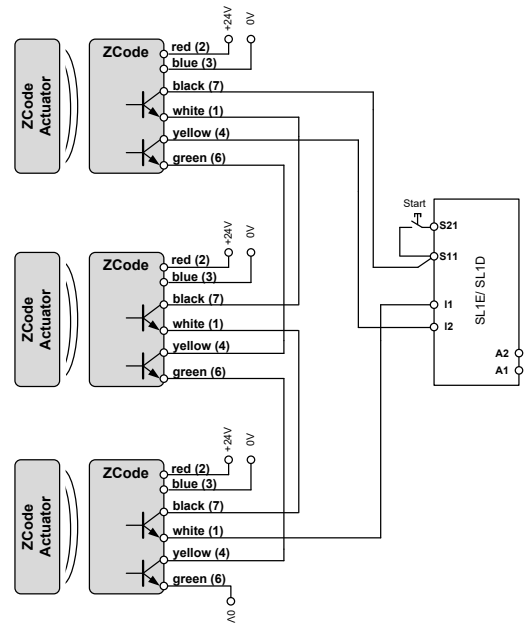

Figure 10: Connecting of 3 (up to 20) ZCode in series to one ZANDER MINOS SL1D / SL1E (up to category 3, PL d)

Safety PLC,
wiring example:
ZANDER TALOS
standard
programs
PR07 and PR08

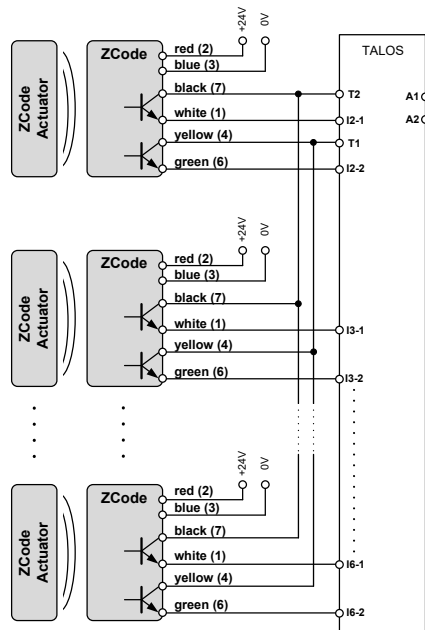

Figure 11 : Connection of ZCodes to one ZANDER TALOS according to the configurations of the standard programs PR07 and PR08 (up to category 4, PL e)

Commissioning Procedure



Attention: During commissioning, the items listed under „Electrical Connection“ must be considered. (see above)

1. Mounting the device:

Mount the device on the safety gate according to the instructions listed under "Mounting". Pay attention to the correct fitting and distance between the switch and actuator.

2. Wiring:

Wire the switch according to your application and performance level with the used safety relay, safety logic or PLC (see e.g. Fig. 5 to Fig. 11).

Caution: The wiring instruction in the user information of the used safety device must be considered.
Wiring only in de-energized state.

3. Starting the device:

Switch on the operating voltage for the safety switch and safety device.

4. Check your application:

After installation always check each switch function by opening and closing each guard individually in turn. Ensure that the green LED at the switch and also the respectively diagnostic LEDs of the safety device are lit while the door is closed and are extinguished when the door is open.

5. Triggering safety function:

Check that the machine stops and cannot be re-started when a switch or a door is open.

User Information

Maintenance

Monthly: Check alignment of actuator and look for signs of mechanical damage to the switch casing.

For applications where infrequent guard access is foreseeable, the system must have a manual function test to detect a possible accumulation of faults. At least once per month for PL e Cat. 3/4 or once per year for PL d Cat. 3 (ISO 13849-1). Where possible it is recommended that the control system of the machine demands and monitors these tests, and stops or prevents the machine from starting if the test is not done (ISO 14119).

Check each switch function by opening and closing each guard individually in turn and ensure that the green LED on the switch and the appropriate LED's on the Safety Relay or Control Device are illuminated when the switch is closed and are extinguished when the switch is open. Check that the machine stops and cannot be re-started when each switch is open.

Never repair any switch, actuator or integral cables. Replace any switch displaying signs of mechanical damage to casing or cables.

The device is otherwise maintenance free, provided that it was installed properly.

What to Do in Case of a Fault?

Device does not switch on:

- Check the wiring by comparing it to the wiring diagrams.
- Check the safety switch for correct adjustment.
- Check if the green LED is lit when the switch is closed.
- Check the operating voltage.

"Commissioning Procedure".

If these steps do not remedy the fault either, return the device to the manufacturer for examination.

Opening the device is impermissible and will void the warranty.

If the fault still exists, perform the steps listed under

Safety Characteristics According to DIN EN ISO 13849-1 EN 62061

The device is certified according to DIN EN ISO 13849-1 up to a Performance Level of PL e .

The specified PL (for applications according to Fig. 5 to Fig. 11) values were determined under the following worst-case conditions for a guard door monitoring.

Safety Characteristics according to DIN EN ISO 13849-1 / EN 62061

Performance Level Category	e (Depending on the application, see Fig. 5 to Fig. 11)
MTTF _d	1100 years
Diagnostic Coverage DC	99%
Safety Integrity Level	SILCL 3
PFD	4.18E-05 (Corresponds to 4.2% of SIL3)
PFH (1/h)	4.77E-10 (Corresponds to 4.8% of SIL3)
Proof Test Interval	20 years
d _{op}	365 days/year
h _{op}	24 hours/day

Techn. Data

Corresponds to the standards	EN 60204-1; EN ISO 13849-1; EN 60947-5-3; EN ISO 14119; UL 508; CSA-C22.2 No.14
Approvals	CE, TÜV, UL
Power supply	DC 24V, +/- 10%
Contact rating outputs	DC 24V, max. 200 mA, short circuit proof
Contact rating auxiliary output	DC 24V, max. 200 mA, short circuit proof
Minimum switched current	10 mA
Dielectric withstand	AC 250 V
Recommended setting gap	5 mm
Switching distance, max.	Sao 10 mm close / Sar 20 mm open
Tolerance to misalignment	5 mm in any direction from 5 mm setting gap
Switching frequency	max. 1.0 Hz
Approach speed	200 mm/min - 1000 mm/s
Body material	red polyester
Protection	IP69K, IP67 (with M12-connector IP67)
Temperature range	-25 °C to +80 °C
Shock resistance	11 ms 30 g accord. to IEC 68-2-27
Vibration resistance	10 - 55 Hz 1 mm accord. to IEC 68-2-6
Cable	PVC 8 core, 6 mm O.D. for 2 NC/ 1NO
Mounting	each 2 x M4 screws; tightening torque max. 2 Nm; any position
Weight	approx. 200 g

User Information

Dimensions

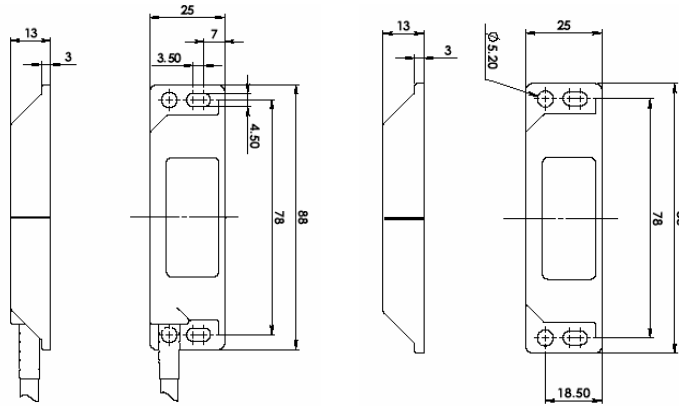

ZCode-LR switch (left) and actuator (right)

3D-CAD-Data available upon request (.step).

Versions

Order No. 941144	ZCode-LR, 5m cable, 2NC/1NO, Mastercode, incl. actuator
Order No. 941145	ZCode-LR, M12, 2NC/1NO, Mastercode, incl. actuator
Order No. 941154	ZCode-LR, 5m cable, 2NC/1NO, Unicode, incl. actuator
Order No. 941155	ZCode-LR, M12, 2NC/1NO, Unicode, incl. actuator
Order No. 941149	ZCode-LR, Replacement Actuator Mastercode
Accessories:	
Order No. 941200	M12 extension cable, 10 m lengths, female, 8-wire, open end cable

CE Konformitätserklärung
 EC Declaration of Conformity
 Déclaration de conformité

Hersteller: H. ZANDER GmbH & Co. KG
 Producer: Am Gut Wolf 15 • 52070 Aachen • Deutschland
 Fabricant:

Produktgruppe: RFID Sicherheitsschalter / Prozesssicherheit
 Product Group: RFID Safety Switches / Process Interlock
 Groupe de produits: RFID Interrupteur de sécurité / Processus gâchette

Produkt Name	Anbringung der CE-Kennzeichnung	Zertifikats-Nr.
Product Name	Affixing of CE marking	No of Certificate
Nom du produit	Application du marque CE	N° du certificat
ZCode-PR/ZCode-LR.....2015	968/FSP 1020.01/15
ZCode-MZ-LU/ZCode-MZ-SU.....2015	968/FSP 1020.01/15
ZCode-MZ-LM/ZCode-MZ-SM.....2015	968/FSP 1020.01/15
ZCode-MZA-LU/ZCode-MZA-SU.....2015	968/FSP 1020.01/15
ZCode-MZA-LM/ZCode-MZA-SM.....2015	968/FSP 1020.01/15
ZCode-MZE-LU/ZCode-MZE-SU.....2015	968/FSP 1020.01/15
ZCode-MZE-LM/ZCode-MZE-SM.....2015	968/FSP 1020.01/15

Die Produkte stimmen mit den Vorschriften folgender Europäischer Richtlinien überein:
 The products conform with the essential protection requirements of the following European directives:
 Les produits sont conformes aux dispositions des directives européennes suivantes:

2006/42/EG : Maschinenrichtlinie	2011/65/EU : RoHS Richtlinie
2006/42/EG : Machinery Directive	2011/65/EU: RoHS Directive
2006/42/EG : Directive <<Machines>>	2011/65/EU: Directive <<RoHS>>
2014/30/EU : EMV Richtlinie	2014/53/EU : RED Richtlinie
2014/30/EU : EMC Directive	2014/53/EU : RED Directive
2014/30/EU : Directive <<CEM>>	2014/53/EU : Directive <<RED>>

Die Übereinstimmung der bezeichneten Produkte mit den Vorschriften der o.a. Richtlinie wird, falls anwendbar, nachgewiesen durch die vollständige Einhaltung folgender Normen:
 If applicable, the conformity of the designated products is proved by full compliance with the following standards:
 Le strict respect des normes suivantes confirme, s'il y a lieu, que les produits désignés sont conformes aux dispositions de la directive susmentionnée:

EN 301 489-1: V2.1.1 (2017)	EN 301 489-3: V1.6.1 (08/2013)
EN 60204-1: 2006+A1:2009+AC:2010	

Gemäß Zertifikat TÜV-Rheinland:
 According to the certificate of TÜV-Rheinland:
 Selon de organisme TÜV-Rheinland:

EN 60947-5-3: 2013	EN 62061:2005 + A2:2015
EN ISO 13849-1:2015	EN ISO 14119:2013

Documentationbeauftragte/r: Christiane Nittschalk
 Documentation manager
 Autorisé à constituer le dossier technique

Aachen, den 04.08.2017

Dipl.-Ing. Walter Zander
 Geschäftsleitung
 General Manager
 Direction

Dipl.-Ing. Alfons Austerhoff
 Leiter CE-Konformitätsbewertung
 Manager for EC declaration of conformity
 Responsable évaluation de conformité CE

F.3.3/023